

Servicing Manual

Manuel de service

STYLE 300 - 300 S

600 - 600 S

1200 S



Schematic diagrams and parts list

Schémas et liste des pièces

230V version

Table of contents

Safety notice	3
Operating instructions	4
Basic list of components needed	5 - 6
Trouble seeking guide	7 - 8
Charge capacitors principle	9
Interconnection diagram	10
Style 300 S and 600 S without casing	11
General information Semiconductors function	12
Adjusting (Réglages) (Einregeln)	13
BOARDS	
PB1 Schematic Board 300 S and 600 S	14 - 15
PB2 Schematic Board 300 S and 600 S	16 - 17
PB2 Schematic Board for 300 and 600 only	18 - 19
PB3 Schematic Board all Style units	20 - 21
PB4 Schematic Board 300 S - 600 S and 1200 S	22 - 23 - 24 - 25
PB4 Schematic Board 300 - 600 only	26 - 27
PB5 Schematic Board for 300 S - 600 S - 1200 S	28 - 29
PB5 Schematic Board for 300 and 600 only	30 - 31
Panel view and parts list	32
REMOTE CONTROL	33
Remote control for 300 S - 600 S and 1200 S	34 - 35
STYLE 1200 S	
Views without casing	36 - 37
PB1 Board assembly for 1200 S (trigger + booster)	38 - 39
PB2 Board assembly for 1200 S (modelling + dump)	40 - 41
PB3 + Assembly board rear capacitors	42 - 43
For notes	44 - 45

IMPORTANT !

The interior of the generator or compact contain components carrying dangerous levels of electric charge, even though the unit has been disconnected from the mains.



ALWAYS TAKE THE FOLLOWING PRECAUTIONS:

1. Always disconnect it from the mains supply, and discharge the unit before (for generator) and after (for compact) removing the outer cover or housing. This is best achieved with a suitable discharge resistor (code 11931 for 230 V and (11930 for 120 V) fitted to a lamphed plug which may be inserted into a lamphed outlet for generator only.
For compact connect the discharge resistor in the flash tube terminals.
2. Take care when opening a generator. Always start by connecting a voltmeter across the storage capacitors, as capacitor drainage may not have occurred due to a fault in the unit.

ACHTUNG GEFAHR !

Auch wenn der Generator vom Netz getrennt ist, können im Innern des Geräts noch gefährliche elektrische Spannungen vorhanden sein.

ACHTUNG GEFAEHRliche STROMSPANNUNG:

1. Bevor Sie ein Blitzgerät öffnen, entladen Sie zuerst die Kondensatoren mittels Entladewiderstand (Best, Nr. 11931 für 230 V)
2. Vorsicht beim Öffnen eines Blitzgeräts. Verbinden Sie sofort ein Voltmeter mit den Kondensatoren, denn diese könnten wegen einer anderen Panne nicht entladen sein.

ATTENTION DANGER !

Des tensions électriques dangereuses restent présentes, ceci même lorsque l'appareil est déconnecté du secteur.

PRUDENCE LORS DE L'OUVERTURE D'UN GENERATEUR OU COMPACT.

1. Déconnecter l'appareil du réseau et avant de procéder à sont ouverture décharger le générateur au moyen du dispositif de décharge (code 11931 pour 230 V) et (11930 pour 120 V)
Pour les compacts retirer la poignée et la chemise métallique ou les coques et procéder à la décharge en connectant le dispositif aux bornes du tube flash.
2. Commencer par vérifier la tension aux bornes des condensateurs. Leur drainage peut ne pas avoir eu lieu, la rupture d' un élément ou d' un conducteur peut en être la cause.

230 V - BASIC LIST OF COMPONENTS NEEDED FOR STYLE UNITS

QTY	CODE N°	DESCRIPTION	USED ON <i>or compatible for :</i>
1	14382 PB1	Trigger- booster assembly board <i>(Circuit PB1 assemblé)</i>	300 - 600
1	14372 PB1	Trigger- booster assembly board <i>(Circuit PB1 assemblé)</i>	300 S - 600 S
1	14391 PB1	Trigger- booster assembly board <i>(Circuit PB1 assemblé)</i>	1200 S
1	14383 PB2	Ouput flash and modelling assembly board <i>(Circuit PB2 assemblé, sortie flash et pilote)</i>	300 - 600
1	14373 PB2	Ouput flash and modelling board assembly <i>(Circuit PB2 assemblé, flash, décharge et pilote)</i>	300 S - 600 S
1	14392 PB2	Ouput flash and modelling assembly board <i>(Circuit PB2 assemblé, flash, décharge et pilote)</i>	1200 S
1	14388 PB3	Capacitor assembly board <i>(Circuit PB3 assemblé, condensateurs)</i>	300 - 300 S
1	14374 PB3	Capacitor board assembly PB3 <i>(Circuit PB3 assemblé, condensateurs)</i>	600 - 600 S - 1200 S
1	14381	Capacitor front assembly board <i>(Groupe frontal de condensateurs supplémentaires)</i>	1200 S
1	14384 PB4	Control assembly board <i>(PB4 Circuit complet de commande)</i>	300 - 600
1	14375 PB4	Control assembly board <i>(PB4 Circuit complet de commande)</i>	300 S - 600 S - 1200 S
1	14395 PB5	Potentiometer assembly <i>(potentiomètre complet avec circuit)</i>	300 - 600
1	14376 PB5	Potentiometer assembly PB5 <i>(potentiomètre complet avec circuit)</i>	300S - 600 S - 1200 S
2	105.049	Triac BTB 24-800BW or T2513NH (charge)	All packs and compacts Compacts and generators Compacts 750S/1500S/Chic
2	105.116	Thyristor X0405NF (trigger)	
2	105.138	Solide state relay triggering S21ME8Y	
1	14033	Transistor Mos BUZ 51 or STP 4NB100 (discharge)	
1	107.019	Buzzer SMA-17L10 <i>(signal acoustique)</i>	
1	111.524	Resistor 3K3/25W (discharge) <i>Résistance de décharge 3K3/25W</i>	
4	14342	Capacitor 2600 µF/360 V	
2	104.122	Doubler capacitor 390 µF/385 V	
2	104.123	Doubler capacitor 150 µF/385 V	
2	103.097	Mains on/off luminous switch <i>(interrupteur principal)</i>	
2	103.096	Momentary luminous switch (green) <i>(interrupteur vert de test)</i>	
1	103.095	Latching switch (orange) <i>(interrupteur de la lampe pilote)</i>	
1	103.094	Latching beep/cell switch (black) <i>(interrupteur cellule et signal de disponibilité)</i>	
1	659.008	Fan with connector <i>(ventilateur avec connecteur)</i>	
1	224.020	Holder for fan <i>(équerre support du ventilateur)</i>	
1	211.884	Screw M4 x 20 synthetic material PA 6.6 <i>(vis de fixation du ventilateur)</i>	

230 V - BASIC LIST OF COMPONENTS NEEDED FOR STYLE UNITS

QTY	CODE N°	DESCRIPTION	USED ON <i>or compatible for :</i>
2	14651	Fuse holder 5 x 20 mm <i>(support de fusible)</i>	Classic + Combi + Chic + Compacts
2	19007	10 fuses 5AT 5 x 20 mm	
2	19020	10 fuses 6.3AT 5 x 20 mm	
2	19022	10 fuses 8AT 5 x 20 mm	
1	224.001 SAV	Housing left and right <i>(boîtier partie gauche et droite)</i>	300 - 600 - 300 S - 600 S
1	224.100 SAV	Housing left and right	1200 S
1	219.008	Rubber handle <i>(poignée caoutchouc)</i>	
1	219.001	Metal chassis <i>(châssis métallique)</i>	300 S - 600 S - 1200 S
1	620.204	Set front ring + locking device <i>(bague frontale complète)</i>	
1	204.131	Front ring bayonet	
1	12076	Synchro socket Elinchrom <i>(prise synchro)</i>	All Compacts/Packs
1	110.104	Synchro socket female jack 3.5 mm	All Style units/Chic Packs
TILT HEAD <i>Fixation rapide pour trépied</i>			
1	14598	Mobile part for tilthead <i>(fixation rapide partie mobile)</i>	All compacts
1	204.132	Fixed parts <i>(parties fixées sur châssis)</i>	
4	209.093	Bolt for tilthead <i>(goujon fileté)</i>	All
2	14492	Plastic level for tilthead <i>(manette de serrage)</i>	
2	224.009	Umbrella tube <i>(tube parapluie)</i>	300 - 600 - 300 S - 600 S
2	224.102	Umbrella tube <i>(tube parapluie)</i>	1200 S
SELF ADHESIVE LABEL <i>Étiquettes autocollantes</i>			
4	205.223	Self adhesive label 300 <i>(étiquette)</i>	
4	205.222	Self adhesive label 600	
4	205.224	Self adhesive label 300 S	
4	205.225	Self adhesive label 600 S	
2	205.221	Self adhesive label 1200 S	
FLASH TUBES			
2	24031	Flash tube <i>(tube flash fixation par vis)</i>	300 - 600 - EL 250 - 500
2	24029	Plug-in flash tube <i>(tube flash embrochable)</i>	300 S - 600 S - EL250C - 500C
2	24068	Plug-in flash tube <i>(tube flash embrochable)</i>	1200 S - Micro 750
4	209.131	Insulating glass for trigger <i>(tube isolant en verre)</i>	
2	224.017	Trigger contact fork <i>(contact d'ionisation du tube flash)</i>	
MODELLING LAMPS <i>Lampes de mise au point (pilote)</i>			
2	23002	100W E 27 Krypton	300 - 600
2	23018	250W E 27 Halogen	300 S - 600 S
2	23022	300 W GX 6.35 Halogen	1200 S
MODELLING FUSE <i>Fusibles pour lampes de mise au point</i>			
For lamps 100 W to 300 W			
2	19033	10 fuses 2.5 AF 5 x 20 mm ø 5 x 20 mm 2.5 AF (fast, flink.) <i>(fusible à fusion rapide)</i>	All Style units (230V)

TROUBLE SEEKING GUIDE

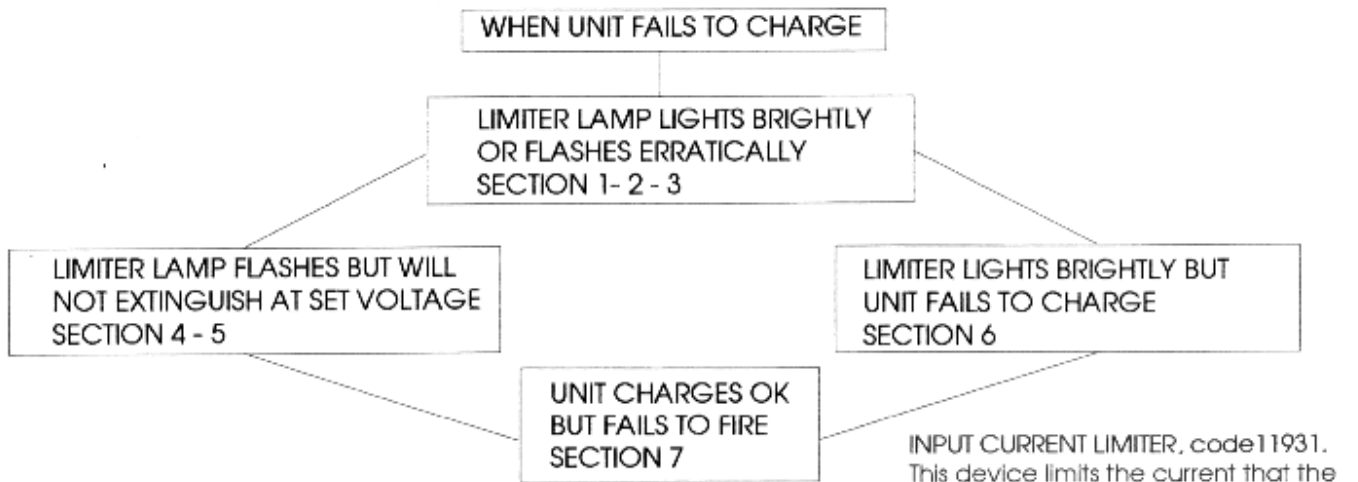

ALWAYS DISCHARGE UNIT BEFORE COMMENCING WORK
(*déchargez l'appareil avant de commencer le travail*)

1- FAULT TRACING FOR BLOWN FUSE

- Wrong value fuse. (*mauvaise valeur de fusible*)
- Charge Triacs short circuit. (*triacs en court-circuits*)
- 5A 1000V Charge Diodes short circuit. (*diodes de charge en court-circuits*)
- S21ME8Y Opto Triac Drivers short circuit. (*optocoupleurs en court-circuits*)
- Opto Triac Drivers feed resistors 330 Ω open circuit. (*résistance de 330 Ω coupée*)
- Voltage reference IC LM2950 short circuit. (*référence de tension en court-circuit*)
- Comparator IC LM 339 short circuit. (*comparateur de tension défectueux*)
- Photoflash Capacitor (2600 μ F) short circuit. (*condensateur en court-circuit*)
- Buz 51 Mosfet transistor short circuit (continual discharge). (*transistor de décharge en court-circuit*)

If in the above list a fault occurs with any of the sections, a,b, c,d. check all the sections as they are related to each other.

2 - TO TRACE FOR A FAULTY PHOTO FLASH CAPACITOR *Recherche dun condensateur défectueux*

Check the following with the Limiter Lamp in circuit and the power setting of the unit set to minimum.
(*Alimenter l'appareil au travers du limiteur de courant Elinchrom, mettre le potentiomètre au minimum, ensuite mesurer simultanément l'évolution de la tension de chaque groupe de condensateurs.*)

Use two voltmeters, one for group A and one for the group B. (*utilisez deux multimètres, un pour le groupe A et un pour le groupe B*)

- Place the common probe on the neutral point of test on the PB3 (see page 21), or on the neutral point on the PB4 (on the Blue point, see page 23 or 25) and the other probe on the 1/2 voltage test point.
- Place the other multimeter on the positive test points on the PB3 (on the Red point, see page 21) and the other probe on the test point «1/2 voltage» (common test point).

Briefly switch the unit «ON» and observe both multimeter readings. One side of the charge capacitors will rise, the other will not. This test will determine on which side the faulty component can be found.

3 - REPLACING A PHOTO FLASH CAPACITOR

- Always discharge the unit before commencing work.
- Check that there is no voltage across the new capacitors.

WHEN A PHOTOFLASH CAPACITOR IS BEING REPLACED, IT MUST BE REFORMED. WITH THE LIMITER IN LINE, SET THE UNIT TO MINIMUM. (*quand un condensateur a été remplacé, pour le former il faut alimenter l'appareil au travers du limiteur de courant; lorsque celui-ci est équipé d'une lampe de 250W il limite le courant à 1A*) Switch on and let the unit charge to minimum power. GRADUALLY increase the voltage until maximum is reached. Repeat this a few times before switching to direct mains.

4 - MODELLING LAMP CIRCUITRY DOES NOT FUNCTION *Le système pilote ne fonctionne pas*

- a) Modelling Lamp fuse blown (quick acting). (*fusible pilote coupé*)
- b) Blown bulb. (*lampe défectueuse*)
- c) 10K Resistor open circuit. (*résistance de 10K ouverte*)
- d) Modelling Lamp Triac (TC1 BT24) open circuit. (*triac ouvert*)
- e) Slider control open circuit. (*potentiomètre à glissière défectueux, circuit ouvert*)
- f) Modelling Lamp Switch open circuit. (*commutateur de la lampe pilote défectueux*)

5 - MODELLING LAMPS WILL NOT VARY *Absence de variation de la lampe pilote*

- a) Modelling Lamp Triac (TC1) short circuit. (light full)
- b) Diac short circuit. (light full) (*diac 32V en court-circuit, la lampe est au maximum*)
- c) The Phase Control Capacitor (C1 220nF) is open circuit or a dry joint (light full)
(*condensateur ouvert ou mauvaise soudure*)
- d) 200K ohm trimmer open circuit (PB5). (*potentiomètre 200 K défectueux, sur PB5, la lampe est éteinte*)
(No light)

6 - FAULT TRACING FOR FIRING FAULTS *Absence d'allumage du tube flash*

- a) Cracked Flashtube. (*tube flash usé ou présentant de fissures*)
- b) Trigger Capacitor (0.1 μ F 400v) open circuit.
- c) 1N4007 Trigger Voltage Rectifier, partial short. (*diode partiellement en court-circuit*)
- d) No voltage present across flash tube. (*absence de tension aux bornes du tube flash*)
- e) Mains Transformer open circuit.
(*transformateur ouvert, absence d'alimentation du circuit de commande*)
- f) Open Flash Switch open circuit. (*interrupteur défectueux*)
- g) Transistors BC 547 and BC 557 on slave PCB short circuit. (*court-circuit*)
- h) 150nF Capacitor on pin 6-7 of the 555 Timer short circuit. (*court-circuit*)
- i) Thyristor X405NF short circuit. (*thyristor en court-circuit*)
- j) Slave cell flooding. (*éblouissement de la cellule*)
- k) Trigger Boost Circuitry faulty (D4 diode, open circuit or C7 capacitor defect).
(*«booster» renforceur d'allumage défectueux*)
- l) Integrated circuit 4001 Nor gate, defect or transistor T3 (*circuit ou transistor défectueux*)
- J) Flashtube aged. Will fire at maximum power but not at minimum although this fault
will be rare as the unit incorporates a trigger boost.
(*tube flash défectueux, verre fissuré ou tube trop utilisé*)

When there is no voltage present across the trigger capacitor try replacing 1N4007 Diode (D1). This sometimes reads OK but is often 'leaky' when a voltage is applied.

7- FAULT TRACING FOR DISCHARGE RESISTOR FAILURE. *Système de décharge défectueux*

- a) 3.3 K Ω / 25W Resistor open circuit. (*résistance de décharge ouverte*)
- b) Mosfet BUZ51 discharge transistor short circuit. (*transistor en court-circuit*)
- c) PCB Tracking blown on front PCB connecting the Mosfet to the negative terminal of
the flashtube and the PCB connector.
(*piste coupée entre le transistor et la borne négative du tube flash*)
- d) Drive IC3 LM339 to the Mosfet short circuit. (*court-circuit*)
- e) ZD1 zener diode or R3 resistor short circuit. (*court-circuit*)
- f) SWTH1 (thermic switch open) (*interrupteur thermique ouvert*)

CHARGE CAPACITORS PRINCIPLE

(It is based on the principle of the dubbing of the peak tension of the line)

Principe de charge des condensateurs

(il est basé sur le principe du doublage de la tension crête du secteur)

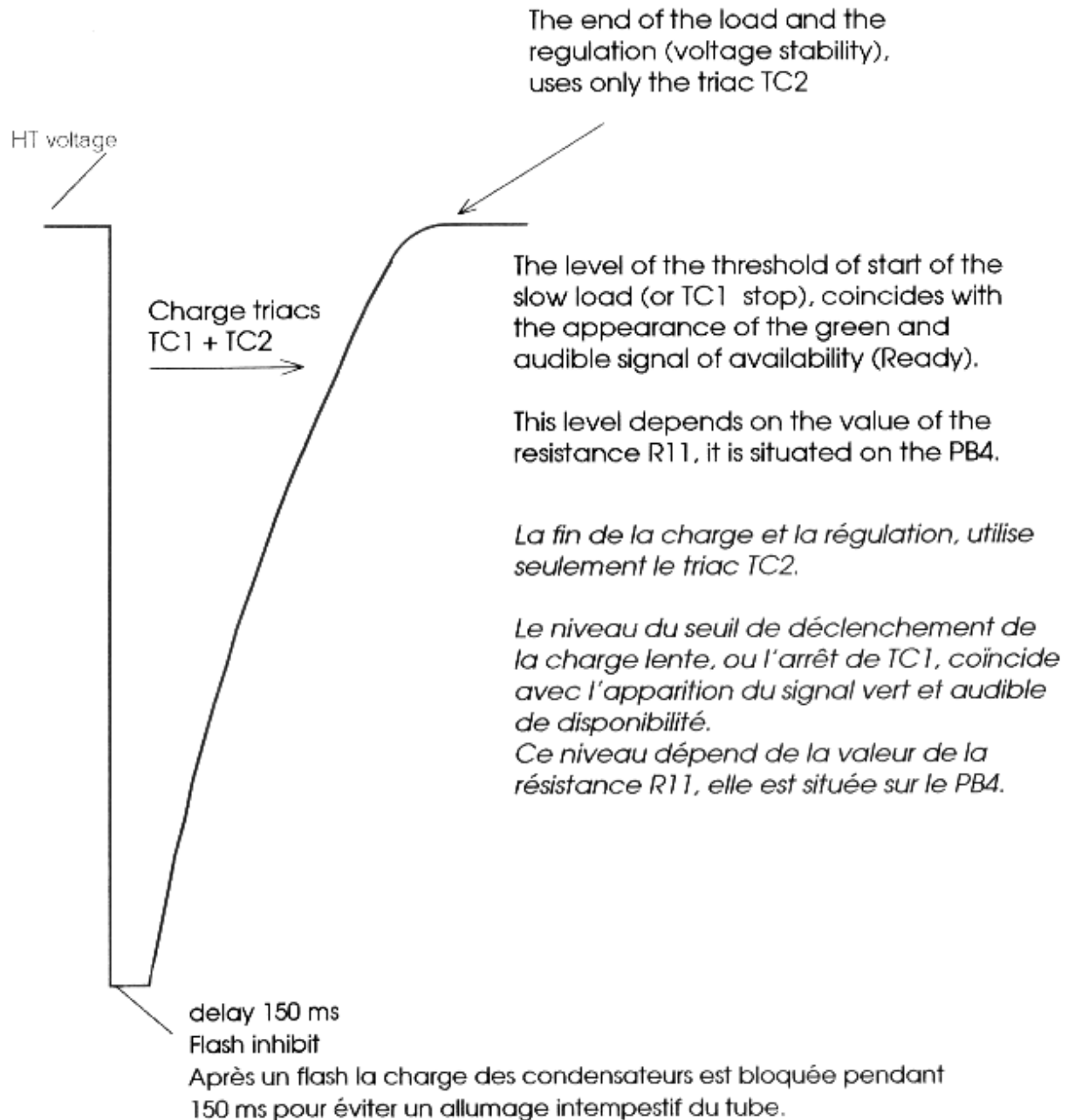

TRIACS FONCTIONS:

TC1: BTB24/800BW or T2513NH (25A/800V) Fast charge.

Triac de la charge rapide

TC2: BTB24/800BW or T2513NH (25A/800V) Charge and regulation.

Triac de la charge lente et de régulation.

CHARGE SPEED	Style 300	Style 300 S	Style 600	Style 600 S	Style 1200 S
on mains 230V/50 Hz	0.25 - 0.6	0.2 - 0.6	0.3 - 0.8	0.25 - 0.8	0.35 - 1.5

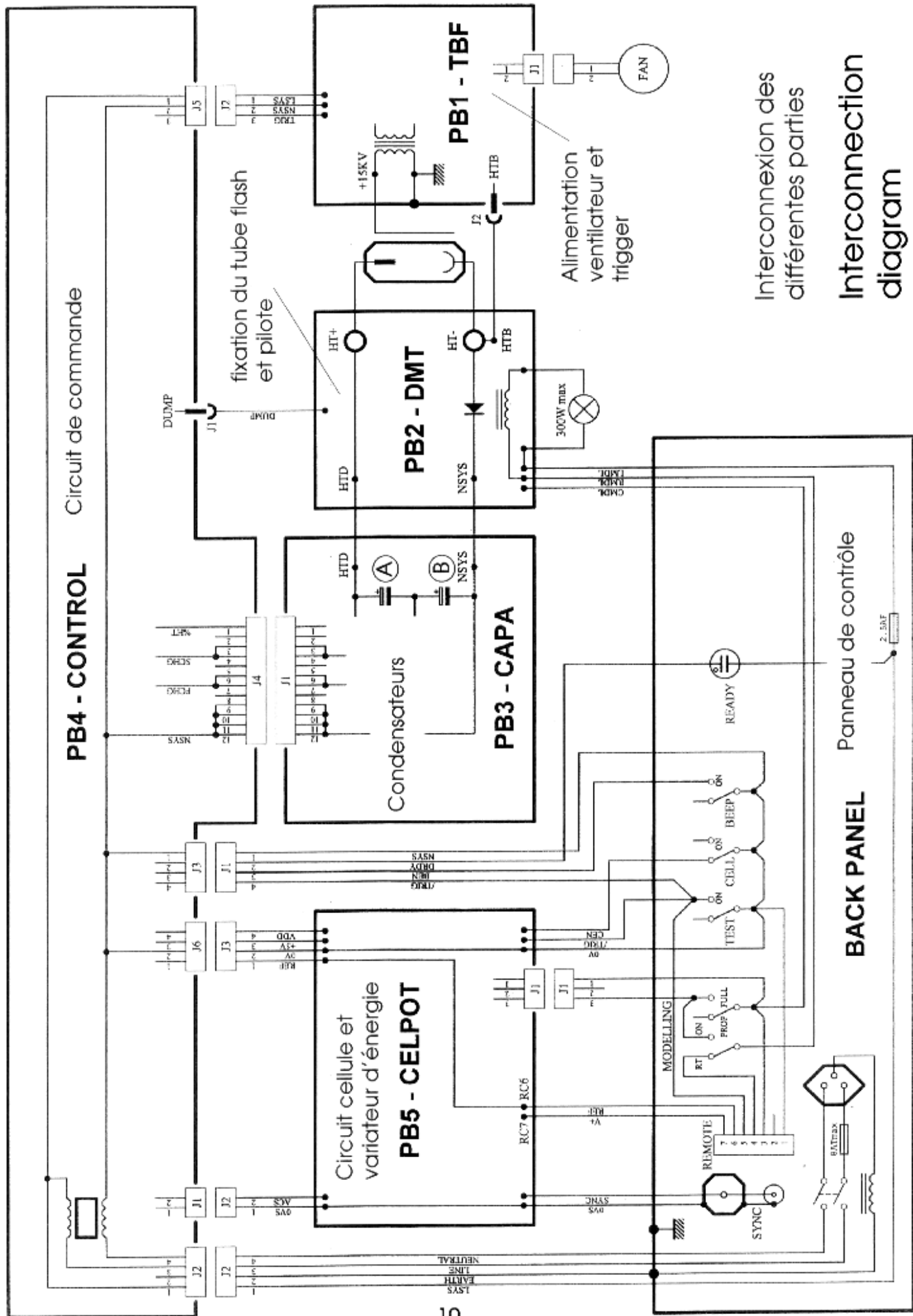

Style 300 S and 600 S

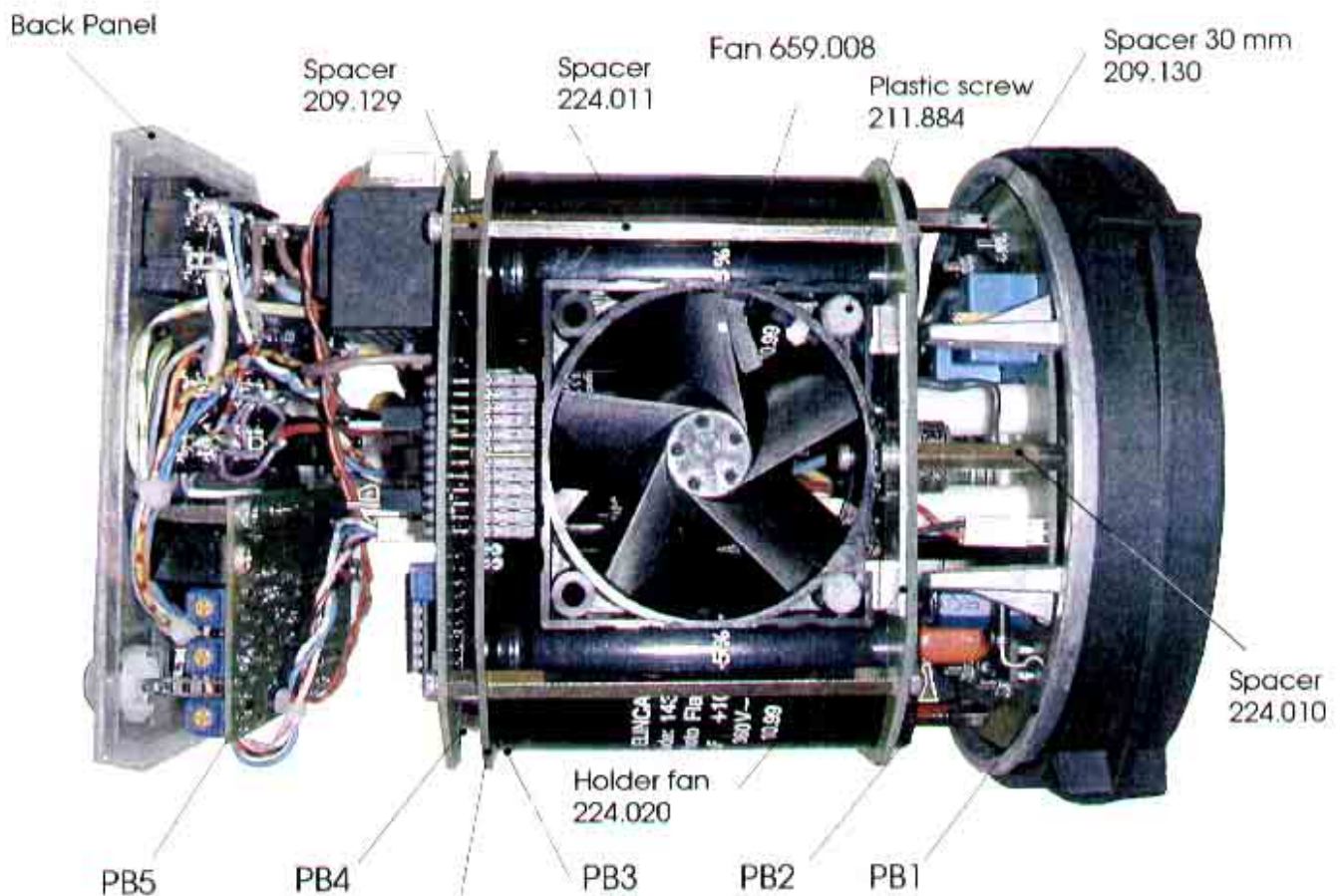

Back Panels
695.002 (600 S)
695.001 (300 S)

659.004 (600)
659.005 (300)

Rubber handle
219.008

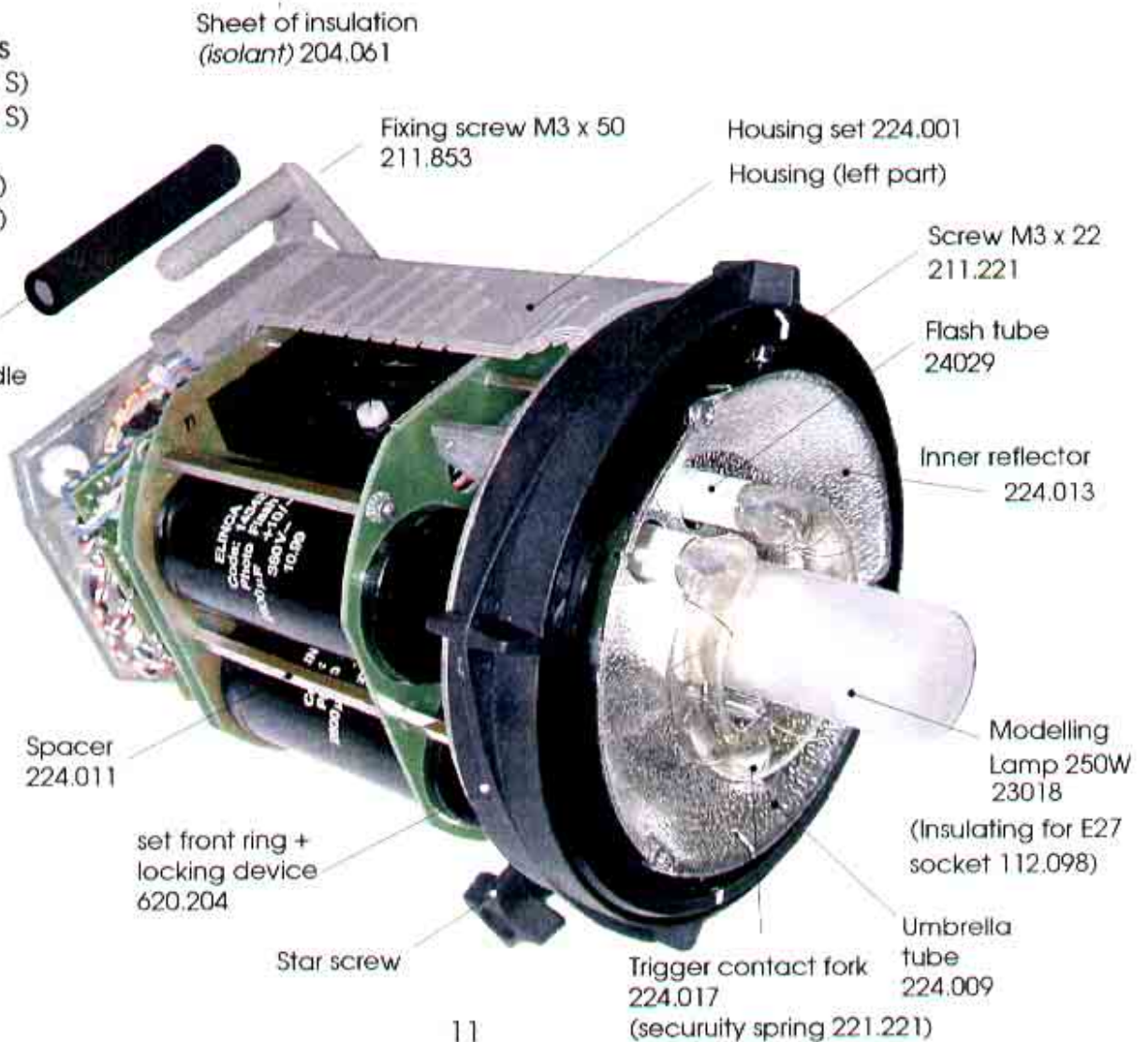

General information Semiconductors

Information sur la fonction des semiconducteurs

TRIACS:

- TC1 on PB4 : BTB24 or T2513NH (24A/800V) Fast charge (*triac de charge rapide*)
TC2 on PB4 : BTB24 or T2513NH (24A/800V) Charge and regulation (*triac de charge et de régulation*)
TC3 on PB4 : Z0103NA (Triac 1A/800V) Drive green button flash READY
(*triac de commutation du signal lumineux "vert" de disponibilité*)
TC1 on PB1 : BTB24 or T2513NH (24A/800V) Modelling lamp control
(*triac de contrôle de la lampe de mise au point "pilote"*)

THYRISTOR:

THY1: Trigger thyristor (*thyristor d'allumage du flash*).

TRANSISTORS:

- T1 on PB2 : BUZ 51 (MOS FET) Dump transistor (*transistor de décharge*).
T3 on PB4 : BC 547 (npn) Allows the trigger when the charge unit is ready
(*autorise le déclenchement lorsque le flash est chargé*).
T1 on PB4 : BC557 (pnp) Allows the slow charge (automatic regulation) and short-circuit OC1
(*il active la charge lente (régulation) en court-circuitant la charge rapide via OC1*).
T2 on PB4 Style "S" only : BC 557 (pnp) Temperature control (LM335) short-circuit OC1 and OC2
(*Dépend du détecteur de température LM335, lorsque la température dépasse 60°C le transistor T2 bloque OC1 et OC2 et interdit la recharge des condensateurs*)

Fast (start charge) : At first T1 is open, VDD is applied to led LD1 and drives OC1 and OC2; the two triacs are active and the system passes then onto fast charge.

Au départ le transistor T1 n'est pas conducteur OC1 et OC2 sont alimentés, les triacs TC1 et TC2 sont conducteurs et chargent le flash rapidement, en fin de charge T1 devient conducteur et bloque OC1, seul le triac TC2 reste conducteur et le système passe alors en charge lente ou de régulation (dans ce cas seul le groupe doubleur de 150µF reste en service).

Slow (charge regulation) : The transistor T1 is close, the optocoupler OC2 only is active and drive the TC2 triac (Only the group of capacitor doublers 150 µF is activated)

INTEGRATED CIRCUITS :

IC1 LM339 Quad comparators

- A part : Drive the dump and controls the new charge after the flash.
(*contrôle la décharge lors d'une réduction de puissance et l'ajustement précis après une recharge*)
B part : Controls and orders the (slow) charge, the ready light and the charge stability
(*autorise la charge lente de régulation et le signal vert de disponibilité*)
C part : Thermal safety control, becomes active when the ambient temperature is above 60°C (the unit cannot recharge any more, the ready light goes out). Style "S" only
(*contrôle la surchauffe de l'appareil et interdit la recharge, lorsque la température du détecteur LM 335 dépasse 60°) seulement sur les Style "S"* .
D part : Controls and orders the start (fast) charge (*contrôle la charge rapide*)

IC 4 555 Timer

Start the flash and inhibit the charge with the diode D1 for 150ms
(*le temporisateur 555 déclenche le flash et interdit la recharge via la diode D1 pendant 150ms*)

IC 5 : IC4001 quad 2-input NOR GATE

- A part : Drive the slow charge (charge stability). (*commande la charge lente et la régulation*)
B part : Authorize the trigger (ready) (*autorise le déclenchement*)
C part : Control SP1 Buzzer (*temporise et active le signal de disponibilité, via le buzzer SP1*)
D part : Controls TC3 the Ready light (*commande l'allumage du témoin vert de disponibilité, via le triac TC3*)

STYLE (S) Adjusting the charge and Modelling lamp

STYLE (S) Réglage de la tension de charge et de la pilote

Justierung der Ladung und des Einstelllichts

ADJUSTING THE CHARGE

The upper and lower limiting values of the charge are controlled by potentiometers VR1/PB4 and VR2 of circuit board PB5. Intermediate values are controlled by the potentiometer (VR3/PB5) which adjusts the linearity of the sliding potentiometer or variator.

VR1/PB4
charge Maxi.
600 Vdc

Use a voltmeter in DC mode to measure the charge voltage capacitors at points 0V (Neutral) and positive HT of PB3 (see page 21).

1. at the 1/1 setting, adjust VR1/ PB4 (max. charge voltage) 595/600 V
2. at the 1/32 (for Style «S») setting, adjust VR2/PB5 (mini. charge voltage) 160 V
3. at the 1/4. (for Style «S») setting adjust *VR1/PB5 (linearity) 310 V

*Note that adjustment is necessary only when the linear sliding potentiometer is replaced.

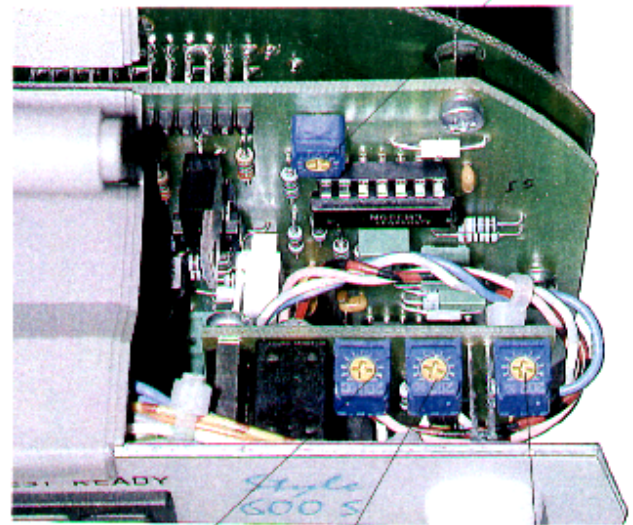

VR4/PB5
Modelling
(pilote)

VR3/PB5
Linearity

VR2/PB5
charge Mini.

ADJUSTING THE MODELLING LIGHT

This adjustment brings the light intensity from full (1/1) down minimum (1/32) with the trimmer (VR4 of PB5).

1. Measure the voltage with a voltmeter VRMS in VAC mode.
2. Modelling light selector: light ON
3. Adjustment 90 V RMS at line 230 V/50Hz, between the yellow thread has the output of the fuse holder and the socket of lamp.

Réglage de la pilote

Mettre au minimum de puissance au 1/32 et régler la tension à 90 VRMS à l'aide de VR .4

Le voltmètre doit être raccordé entre le fil jaune situé à la sortie du fusible pilote et l'autre conducteur de la lampe (par exemple la douille ou le fil qui vient du triac)

For Style 300 and 600 See page 27 and 31

JUSTIERUNG DER LADUNG

Die oberen und unteren grenzwerte der Ladung werden von den Potentiometern VR 1 der Leitenplatte PB4 und VR2 der Leitenplatte PB5 gesteuert.

Die Zwischenwerte hängen vom Regelwiderstand VR 3 ab, der die linearität des Schiebereglers justiert.

Ein auf Gleichstrom geschalteter Voltmeter dient zur Messung HT and den messpunkten (Neutral) und (Positive HT point) von PB3. Siehe Seite 21

1. Bei Anwahl 1200 J für Style 1200 S justieren VR1/PB4
600 J für Style 600 S justieren VR1/PB4 (max. Ladespannung) 600 V
300 J für Style 300 S justieren VR1/PB4
2. Bei Anwahl 37 J für Style 1200 S justieren VR2/PB5
18 J für Style 600 S justieren VR2/PB5 (mini. Ladespannung) 160 V
9 J für Style 300 S justieren VR2/PB5
3. Bei Anwahl 212 J für Style 1200 S justieren VR1/PB5
106 J für Style 600 S justieren VR1/PB5 (Linearität. Ladespannung) 310 V
53 J für Style 300 S justieren VR1/PB5

JUSTIERUNG DES EINSTELLICHTS

Am einfachsten führt man diese Einstellung mit einer Spannungsmessung Zwischen dem gelben Drath (Sicherungshalter) und dem Kontakt der Einstellampe durch:

1. Spannung mit auf Wechselstrom geschaltetem Voltmeter und dem dazu bestimmten Lampensockel messen.
2. Einstelllicht - Wählschalter EIN
3. Justierte Spannung bei mini. Leistung 90 VRMS für Netzspannung 230 VAC/50Hz.

Für 300 und 600 sehen Sie Seite 27 und 31

14372 PB1 for Style 300 S and 600 S Trigger + booster and supply fan

Part Nb	Qty	Designation	Identification
100.060	1	ZS1052/1(trigger coil) <i>(bobine d'amorçage)</i>	TR1
104.006	1	4.7nF/500 V	C2
104.007	1	10nF	C1
104.012	1	47nF/250 V	C5
104.017	1	100nF/400 V	C6
104.025	1	1,µF/400 V	C9
104.124	1	330nF/400 V	C7
105.011	1	1 N5359B (24V/5W zener diode)	ZD1
105.057	1	CSB4 (rectifier bridge)	BR1
105.116	1	X0405NF (thyristor)	TY1
110.072	1	Fan connector	J 1
110.134	1	Borne à visser 3p CSF-03001 Connector with screws	J2
111.038	1	39R/3W	R4
111.065	1	10K/2W	R3
112.056	1	Trigger Eyelet terminal <i>(rivet)</i>	15KV
112.071	1	LP 2.8 mm (tab/cosse)	HTB
121.102	1	1K	R1
121.220	1	22R	R2
121.394	1	390K	R5
14009	2	1N4007 (1A /400 V diode)	D1- D4
14053	1	330µF/50 V (capacitor)	C8
500.600	1	Gaine PVC ø 6 x 50 mm (insulation)	
500.429	1	Fil 0.5 mm ² Brun L = 200 mm	LSYS
500.430	1	Fil 0.5 mm ² Bleu L = 200 mm	NSYS
500.431	1	Fil 0.5 mm ² Vert L = 200 mm	TRIG
14082a	1	PCB nu (without elements)	

Remember:

14372 PB1 for Style 300 S and 600 S (With supply for Fan)

14382 PB1 for Style 300 and 600 (Without supply for Fan)

14391 PB1 for Style 1200 S (Special supply, with two capacitors 1µF/400V)

14372 PB1 for Style 300 S and 600 S

Trigger + booster and supply fan

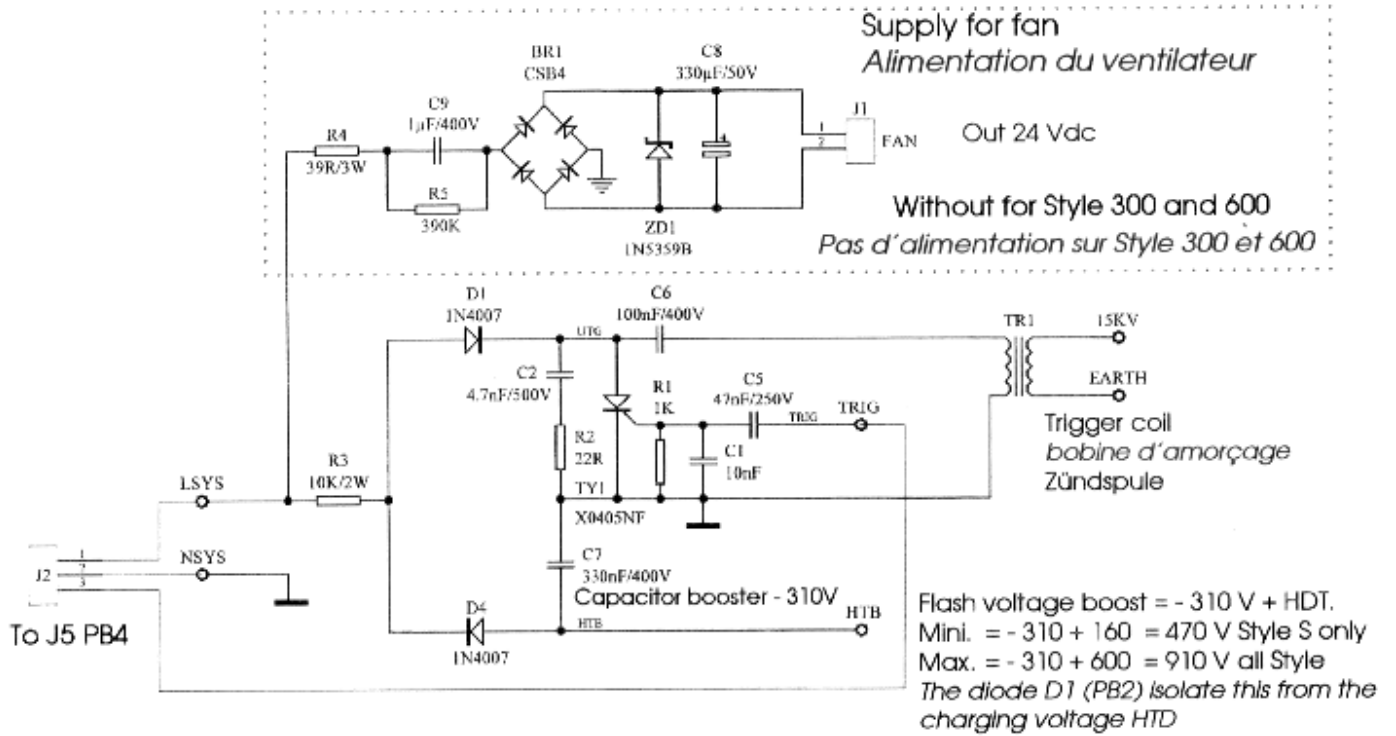

Thyristor X0405NF
4A/800V

cathode (K)
gate (G)
anode (A)

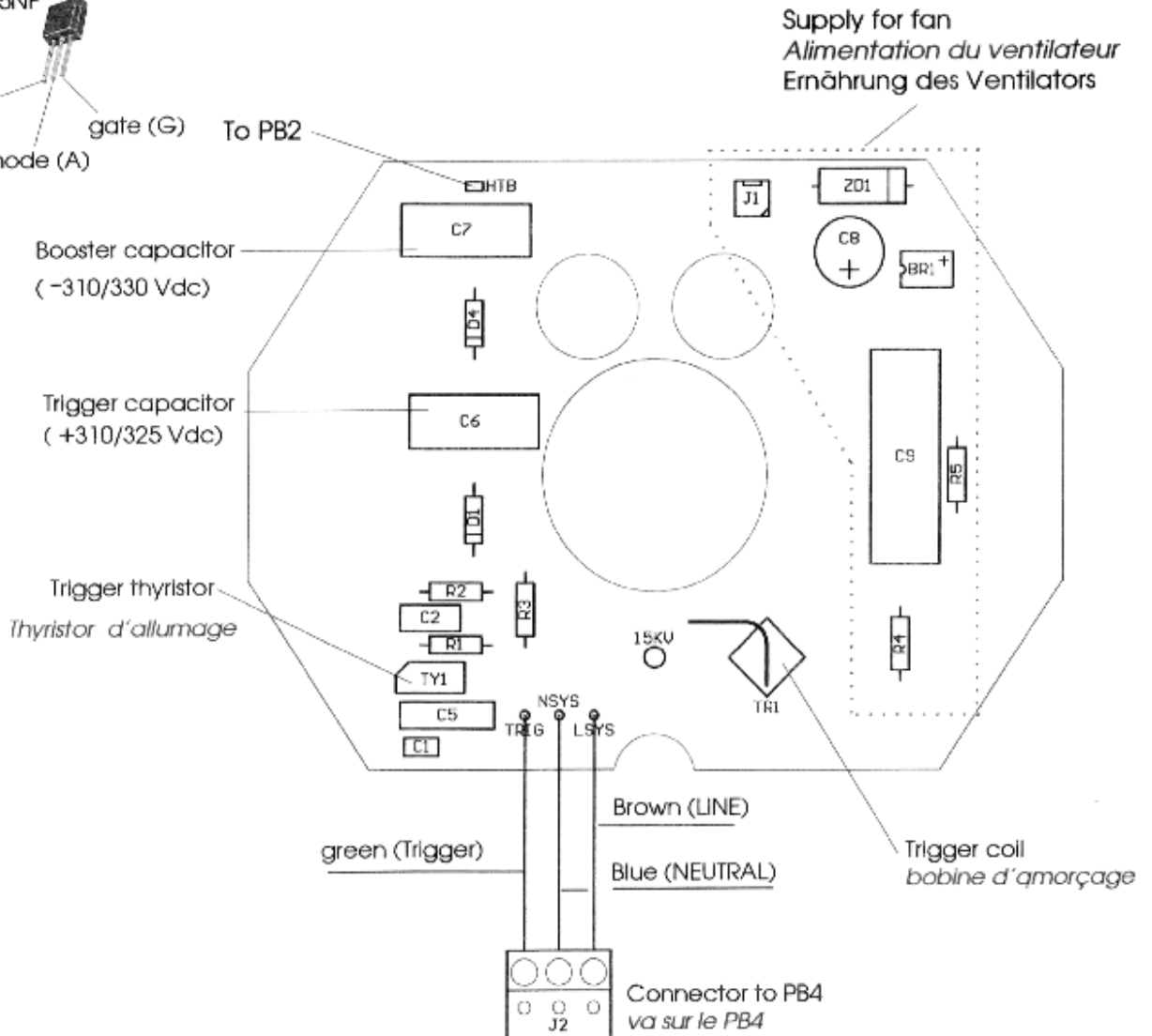

14373 PB2 for Style 300 S and 600 S

Part Nb	Qty	Part	Identification
100.047	1	1,8 mH/2.5A Self (disturbances choke)	L1
101.229	1/3	Manchon SIL 12 X 50 (insulation tube)	R4
104.013	1	47nF/X2 (capacitor)	C2
104.018	1	220nF/250 V	C1
105.006	1	13V zener diode	ZD1
105.049	1	BTB24 triac (24A/800V)	TC1
105.087	1	70HF80 Power diode	D1
111.524	1	3K3/25W (discharge resistor)	R4
112.017	1	Socle E27 (Lampholder)	LP1
112.070	2	Broche 1365 B (contact)	LP1
112.076	2	Cosse 2.8 x 0.8 (soldering lug)	J1 J2
112.101	2	Borne de fixation tube embrochable (Terminal for Plug-In flash tube)	HT+ HT-
121.103	1	10K	R1
121.229	1	220R	R2
121.564	1	560K/2500 V	R5
121.569	1	560K	R3
203.010	2	Ecrou M5 (Nut for terminal flash tube)	HT+ HT-
203.031	1	Ecrou combi M3 (Security nut)	LP1
204.128	1	Joint torique (for 100.047)	L1
209.132	2	Entretoise ø 8x5 (Spacer)	R4
210.004	2	Rondelle éventail (security washer)	HT+ HT-
210.119	1	Rondelle M6 x 0.8 (washer)	D1
211.207	1	Vis M3 x 20 (screw)	LP1
14015	1	Diac 32 V	DD1
14032	1	100°C Thermal switch	SWTH 1
14033	1	BUZ51 or ST 4N100 Transistor Mos	T1
14083a	1	PCB nu (without elements)-	
500.439	1	Fil 0.75 mm ² Noir L = 40mm	D1
500.440	1	Fil 0.75 mm ² Rouge L = 180 mm	HTD
500.441	1	Fil 0.75 mm ² Bleu L = 190 mm	NSYS
500.443	1	Fil 0.5 mm ² Vert L = 150 mm	DUMP
500.442	1	Fil 0.5 mm ² Noir L = 200 mm	RMDL
500.444	1	Fil 0.5 mm ² Noir L = 40 mm	HTB
500.445	1	Fil 0.5 mm ² Rouge L = 200 mm	CMDL
500.446	1	Fil 0.5 mm ² Jaune L = 210 mm	LMDL

14373 PB2 Modelling lamp and Dump (230V)

Printed board assembly for 300 S and 600 S

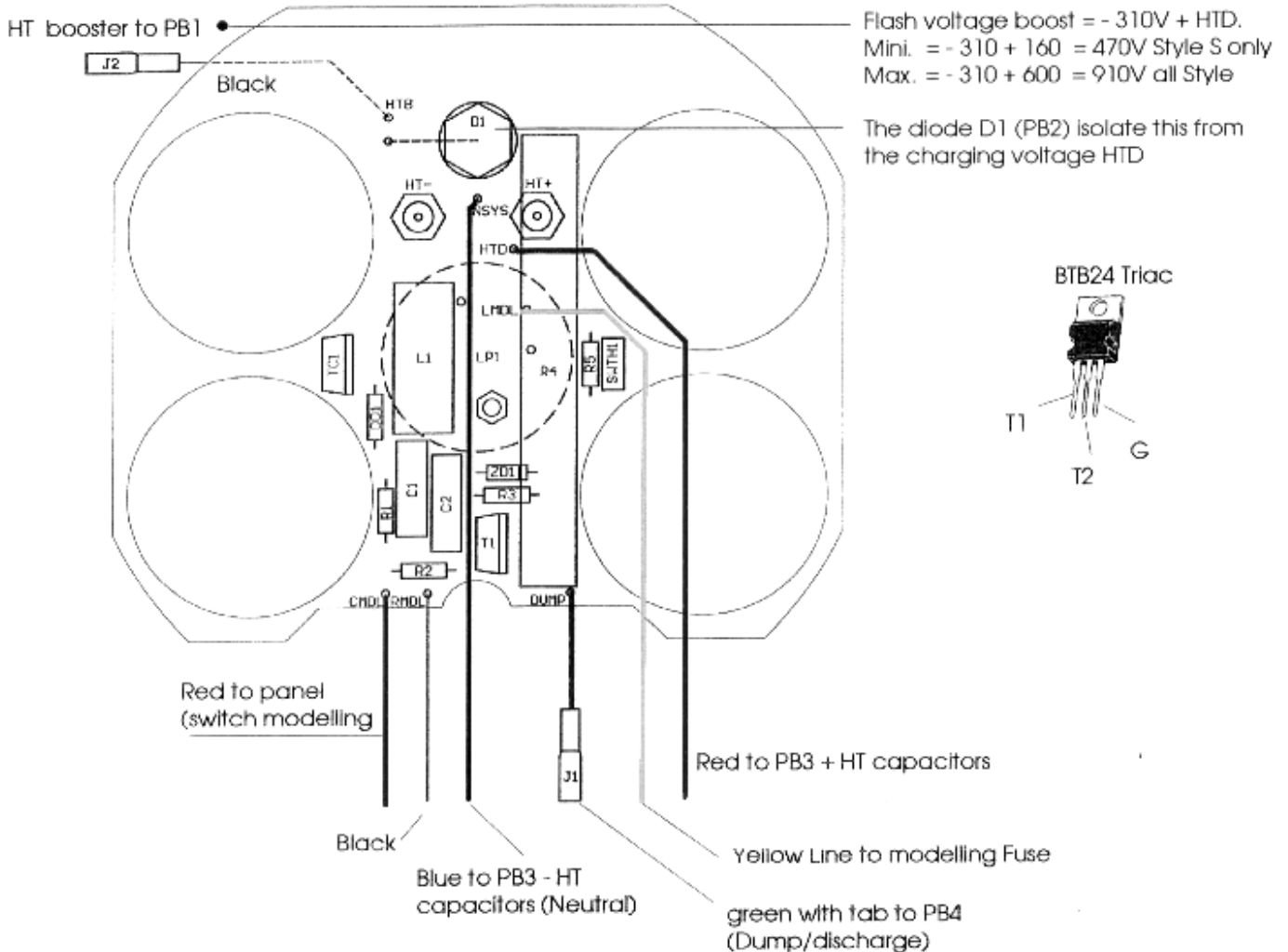
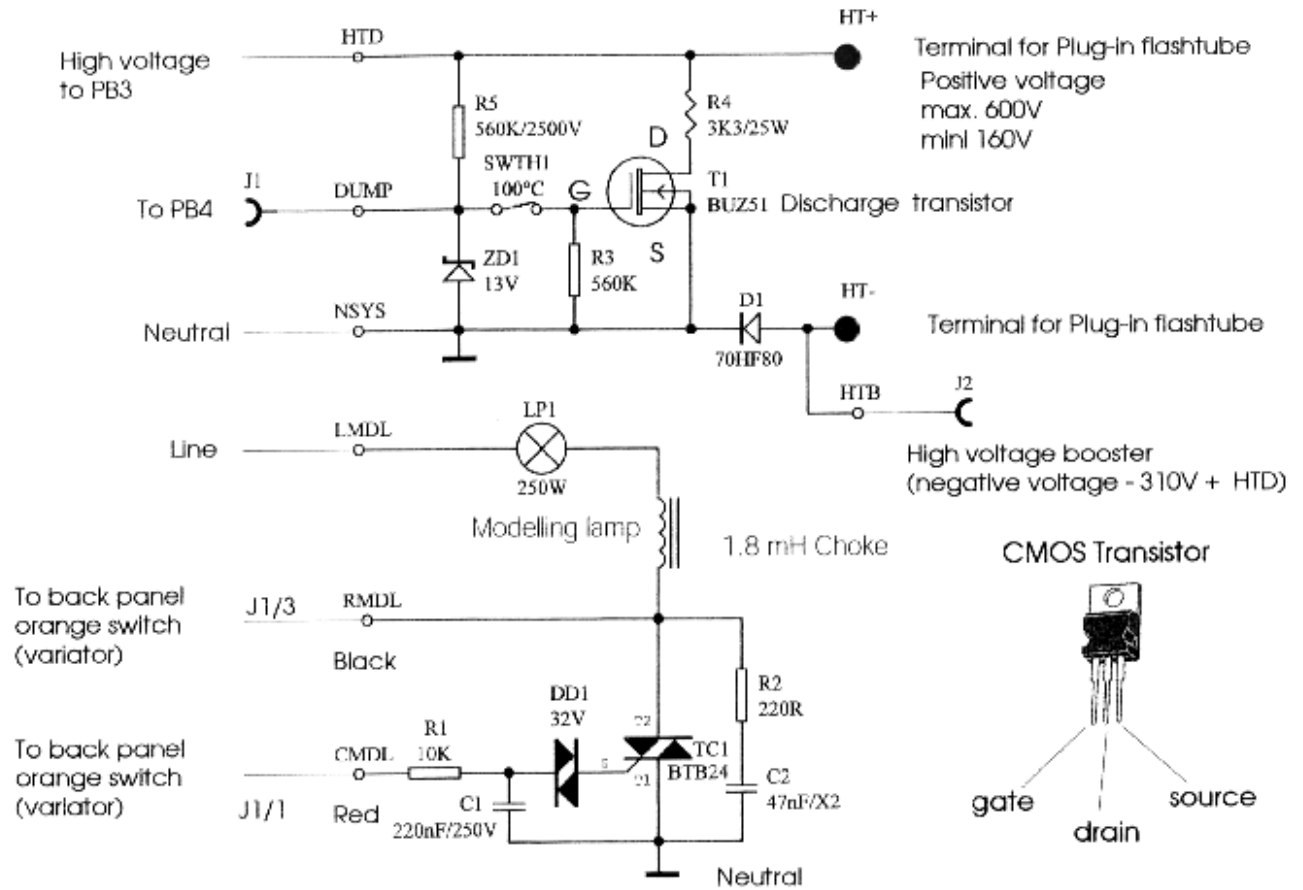

14383 PB2 for Style 300 and 600 only

Part Nb	Qty	Designation	Identification
100.047	1	1,8 mH/2.5A Self (choke)	L1
104.013	1	47nF/X2 (capacitor)	C2
104.018	1	220nF/250 V	C1
105.049	1	BTB24 modelling triac 24A/800V	TC1
105.087	1	70HF80 Power Diode	D1
112.017	1	Socle E27 (E27 Lampholder)	LP1
112.070	2	Broche 1365 B	LP1
112.076	2	Cosse 2.8 x 0.8 (flat receptacles)	J1 J2
510.022	2	Borne fixation (terminal for flash tube)	HT+ HT-
121.103	1	10K	R1
121.229	1	220R	R2
203.010	2	Ecrou M5 (Nut for terminals)	HT+ HT-
203.031	1	Ecrou combi M3 (Security Nut)	LP1
204.128	1	Joint torique (rubber ring for 100.047)	L1
209.132	2	Entretoise \varnothing 8 x 5 (Spacer)	R4
210.004	2	Rondelle éventail (lockwasher)	HT+ HT-
210.119	1	Rondelle M6 x 0.8 (washer)	D1
211.207	1	Vis M3 x 20 (screw)	LP1
14015	1	Diac 32V	DD1
14083a	1	PCB nu (without elements)	
500.490	1	Fil 0.75 mm ² Noir L = 40 mm	D1
500.440	1	Fil 0.75 mm ² Rouge L = 180 mm	HTD
500.441	1	Fil 0.75 mm ² Bleu L = 190 mm	NSYS
500.442	1	Fil 0.5 mm ² Noir L = 200 mm	RMDL
500.444	1	Fil 0.5 mm ² Noir L = 40 mm	HTB
500.445	1	Fil 0.5 mm ² Rouge L = 200 mm	CMDL
500.446	1	Fil 0.5 mm ² Jaune L = 210 mm	LMDL

14383 PB2 Modelling lamp (230V) for Style 300 and 600 only

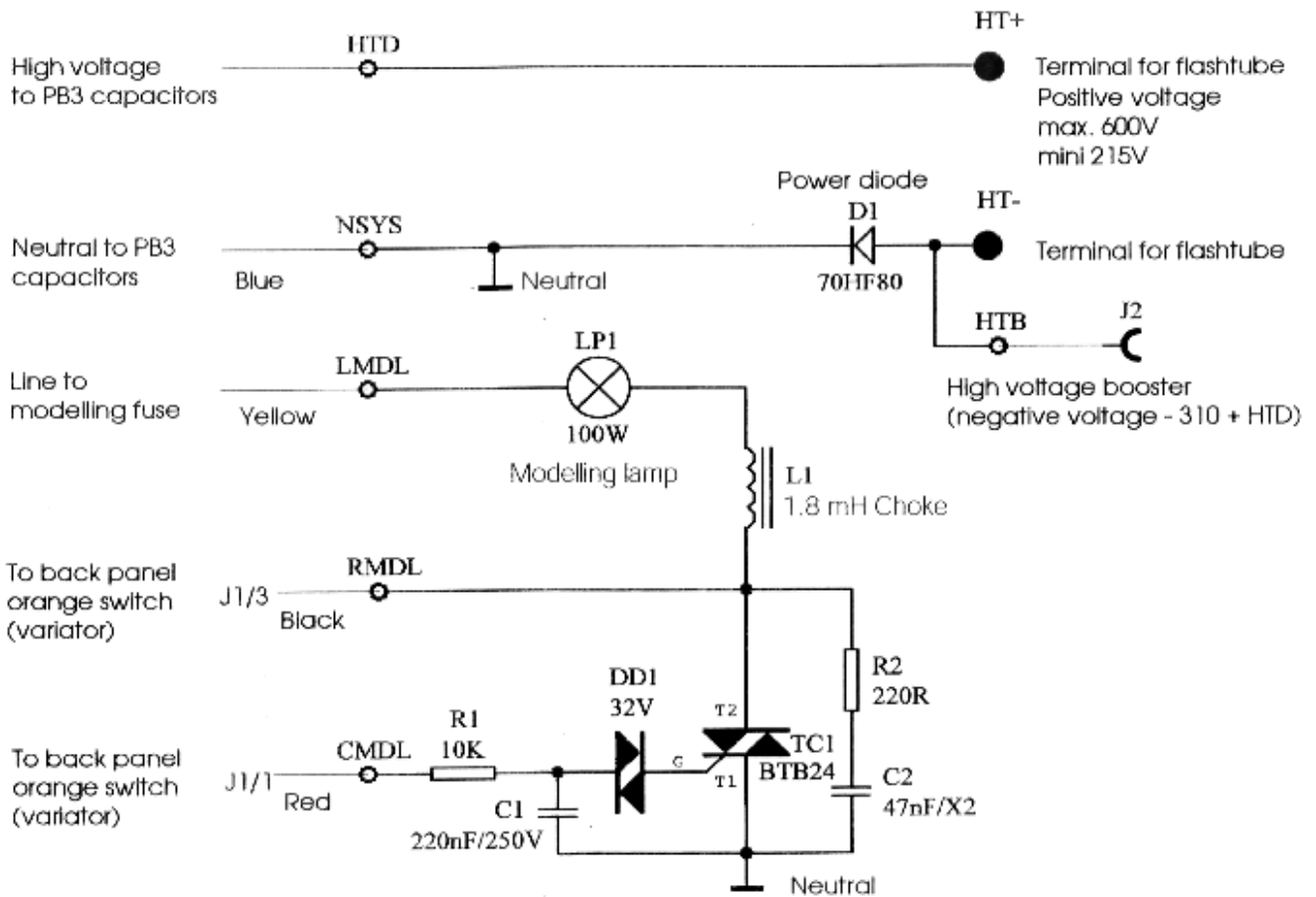

Flash voltage boost = - 310V + HTD.
Mini. = - 310 + 215 = 525V
Max. = - 310 + 600 = 910V all Style

The diode D1 (PB2) isolate this from the charging voltage HTD

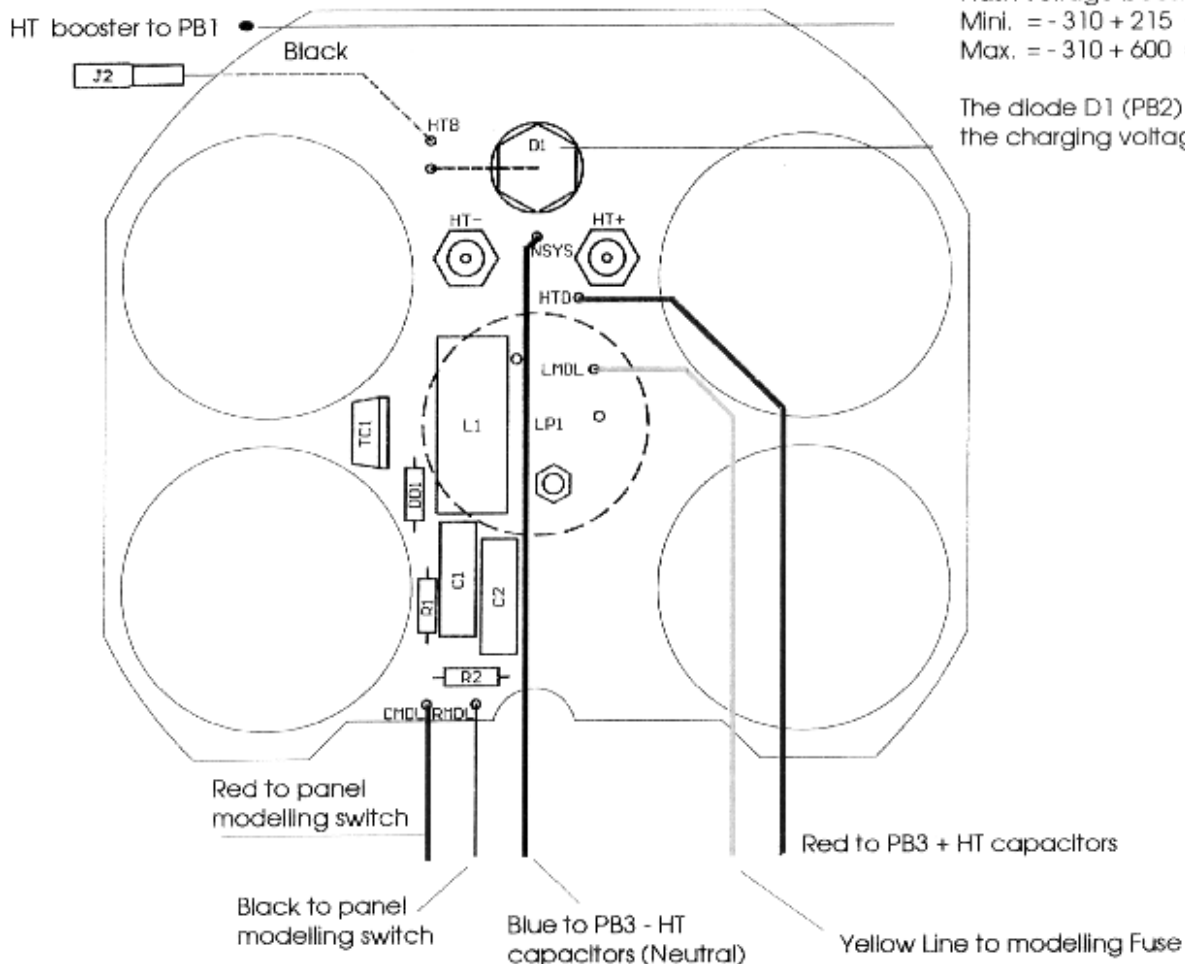

14374 PB3 Assembly (230 V)

Printed board with capacitors for 600 - 600 S and 1200 S*

Part Nb	Qty	Part	Identification
104.122	2	390µF/385 V (Doubler capacitors)	C3 C4
104.123	2	150µF/385 V (Doubler capacitors)	C1 C2
105.050	2	BY550 (5A/1000 V rectifier diodes)	D5 D6
110.129	1	BL111508112Z (Female crimp)	J1
112.071	3	LP2.8 (Tab 2.8 mm)	HTD HT/2NSYS
121.394	6	390K	R1 R2 R3 R4 R7 R8 (ref. resistors)
14084a	1	PCB (without elements)	
14342	4	2600µF/360V (Flash capacitors)	C5 C6 C7 C8
14342	2	For 300 and 300 S	C6 C8 only
14430	4	1N5408 diode (3A/1000 V) (protective diodes)	D1 D2 D3 D4

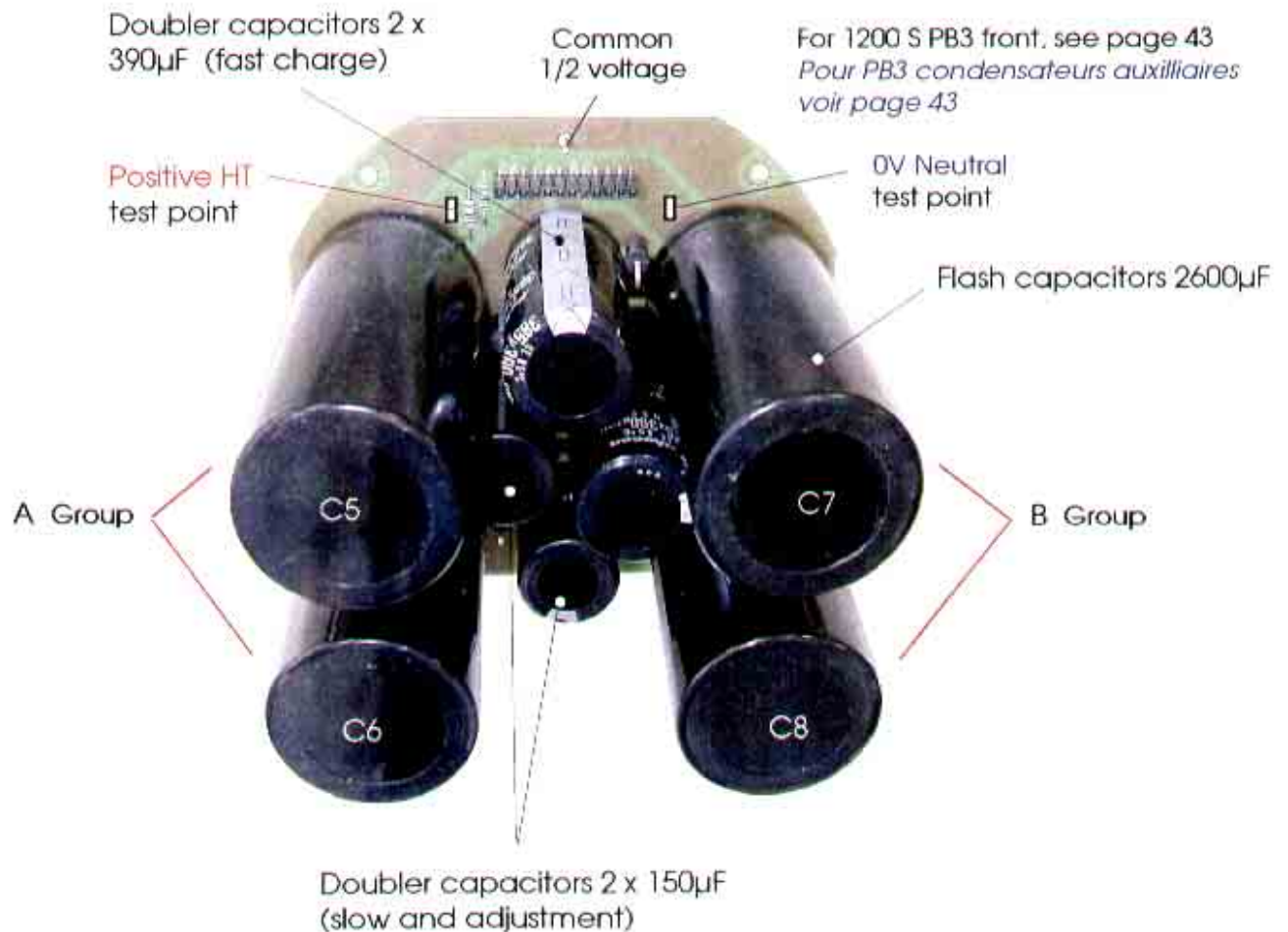

14375 PB4 CONTROL for STYLE 300 S - 600 S and 1200 S (230V)

Circuit de commande, repérage des points de mesure

Anweisung der Meßpunkte

This resistor determines the signal of ready (full for 210 Vac)

Charge triacs

FLASH ADJUSTMENT

Adjust VR1 full power MAX : 595 VDC

Opening of the load (for service only)
ouvert, la charge des condensateurs est supprimée

Voltage Control (Comparator)

Brown thread (Jump)

Out 15 VAC to PB5
Brown
Red

0 V (Neutral)

Varistor /Transient voltage suppression

To panel PB5 cell/variator

Trigger

Line filter

To panel Mains switch

Ground 0 V (Neutral)

- Output + 18 V
- + 12 V (VDD)
- + 5 V
- °K
- Voltage charge Ref.
- Charge Regulation
- 3.3V ref. cut-out
- Dump
- Trigger
- Ready

To panel Cell/Beep and Test switches

FLASH ADJUSTMENT Style "S" only

- 1* adjust VR1 full power MAX : 595 / 600 V
- 2* adjust (PB5) VR2 mini power MINI : 160 V
- 3* adjust (PB5) VR3 medium (linearity) : 310 V
- 4* verify full power with VR1 PB4

14375 PB4 - CONTROL BOARD

For STYLE 300 S/600 S/1200 S (230V)

Part N°	Qty	Part	Identification
100.055	1	BV030-2259 (transformer 2 x 15 V)	TR1
104.007	1	10nF (ceramic capacitor)	C13
104.015	7	100nF ceramic capacitor	C6 C7 C10 C11 C15 C18 C19
104.019	1	0.22pF/X2 (capacitor)	C1
104.029	2	101JF/16 V	C8 C9
104.062	1	0.11JF/X2 (capacitor)	C5
104.064	1	330nF (capacitor)	C16
104.066	5	100nF (capacitor)	C14 C17 C20 C21 C22
104.071	1	150nF (capacitor)	C12
104.106	2	2.2nF/Y (capacitor)	C2 C3
105.048	1	IC 4001 Quad 2 input Nand	IC5
105.049	2	BTB24 ChargeTriac (24 A/800 V)	TC1 TC2
105.051	2	1N4148 Diode 75V/150 mA	D1 D3
105.057	1	CSB4 Bridge rectifier	BR1
105.063	1	78L12 Regulator 12V	IC1
105.089	1	LP2950AC (5V Regulator)	IC2
105.108	1	Z0103NA Triac 1A/800V	TC3
105.125	1	BAT85 Schottky diode	D2
105.138	2	S21ME8Y solid state relay	OC1 OC2
105.201	1	LM335 temperatur detector	TS1
107.019	1	SMA 17-10 Buzzer	SP1
108.024	1	L424GDT Green LED	LD1
109.023	1	2K Potentiometer	VR1
110.063	2	Socle 14p (IC socket)	IC3 IC5
110.072	1	2pM Molex	J1
110.091	2	Socle 6p (IC socket)	OC1 OC2
110.092	1	Socle 8p	IC4
110.123	1	2pM Headers/ connectors	J7
110.130	1	SL 11/240/12 Z (Headers/connectors)	J4
110.131	2	4pM Molex connector	J3 J6
110.135	1	CSM-040A1	J2
110.136	1	CSM-030A1	J5
111.061	1	250Vac Varistor	VDR1
112.071	3	LP 2.8 x 0.8 (Tab 2.8 x 0.8 mm)	0V DUMP LSYS
112.076	1	Cosse2.8 x 0.8 (Flat receptacle)	LCHG
120.001	5	0R (Jump)	R24 REG TRIG VDD V+
121.104	3	100K	R14 R16 R19
121.105	4	1M	R13 R18 R21 R31
121.153	2	15K	R17 R11 (Ready for 210 Vac)
121.182	2	1K8	R7 R12
121.222	1	2K2	R28
121.223	1	22K	R26
121.274	1	270K	R22
121.332	2	3K3	R8 R9
121.339	4	330R	R2 R3 R6 R10
121.392	1	3K9	R29
121.394	1	390K	R20
121.473	6	47K	R4 R5 R23 R25 R32 R33
121.564	1	560K/2500V (Resistor HT)	VR1
121.752	1	7K5	R15
14012	1	BC547 NPN transistor	T3
14013	2	BC557 PNP transistor	T1 T2
14034	1	LM339 Quad comparator	IC3
14052	1	220µF/25V Electrolytic capacitor	C4
14085a	1	PCB nu (board without components)	
14629	1	2 x 2.7mH Self (Choke)	L1
54013	1	LM555 IC Timer	IC4
500.089	1	Fil 0.5mm2 Brun L = 60mm	LCHG

14375 PB4 CONTROL BOARD

For STYLE 300 S/600 S/1200 S (230V)

Circuit de commande

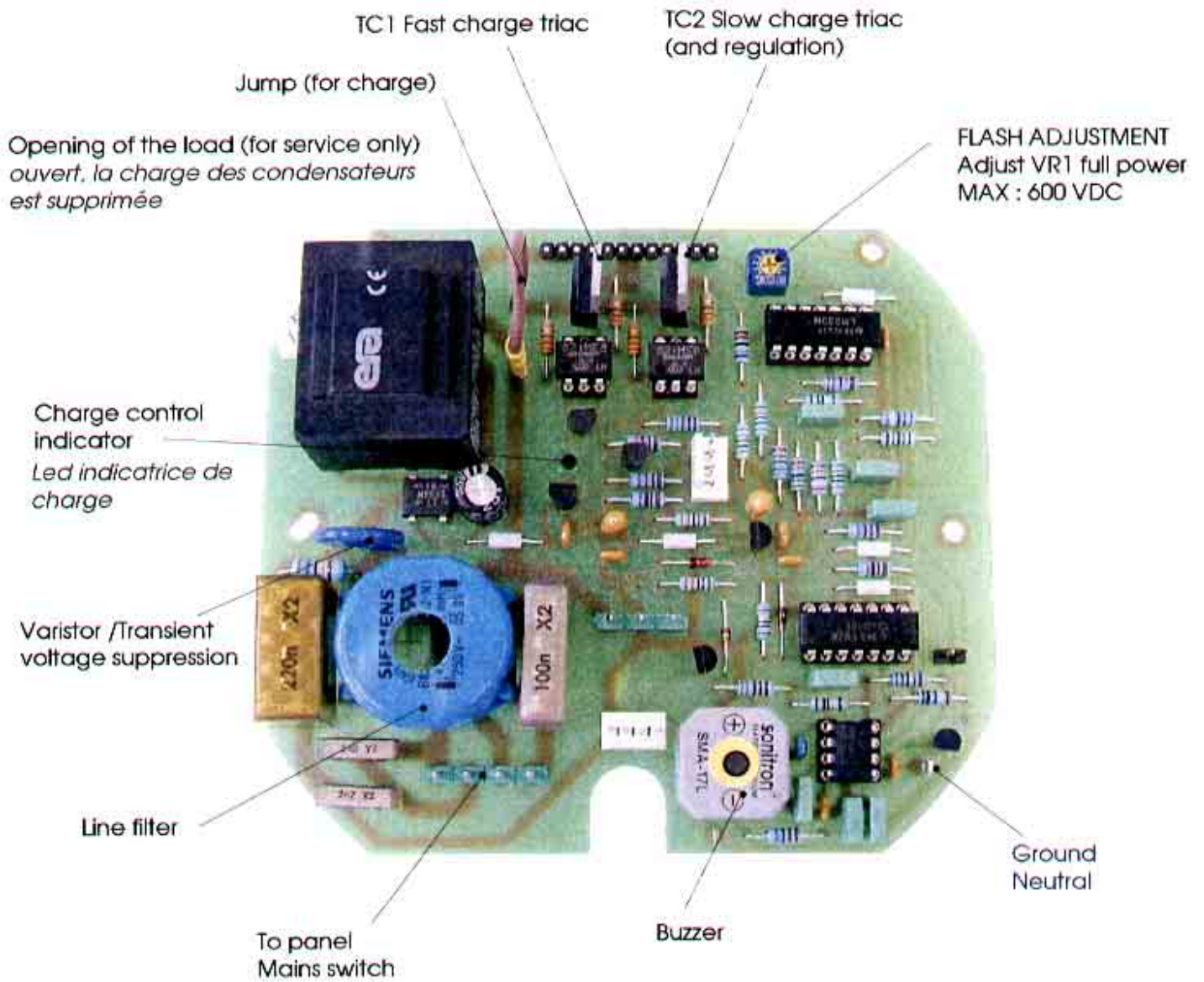

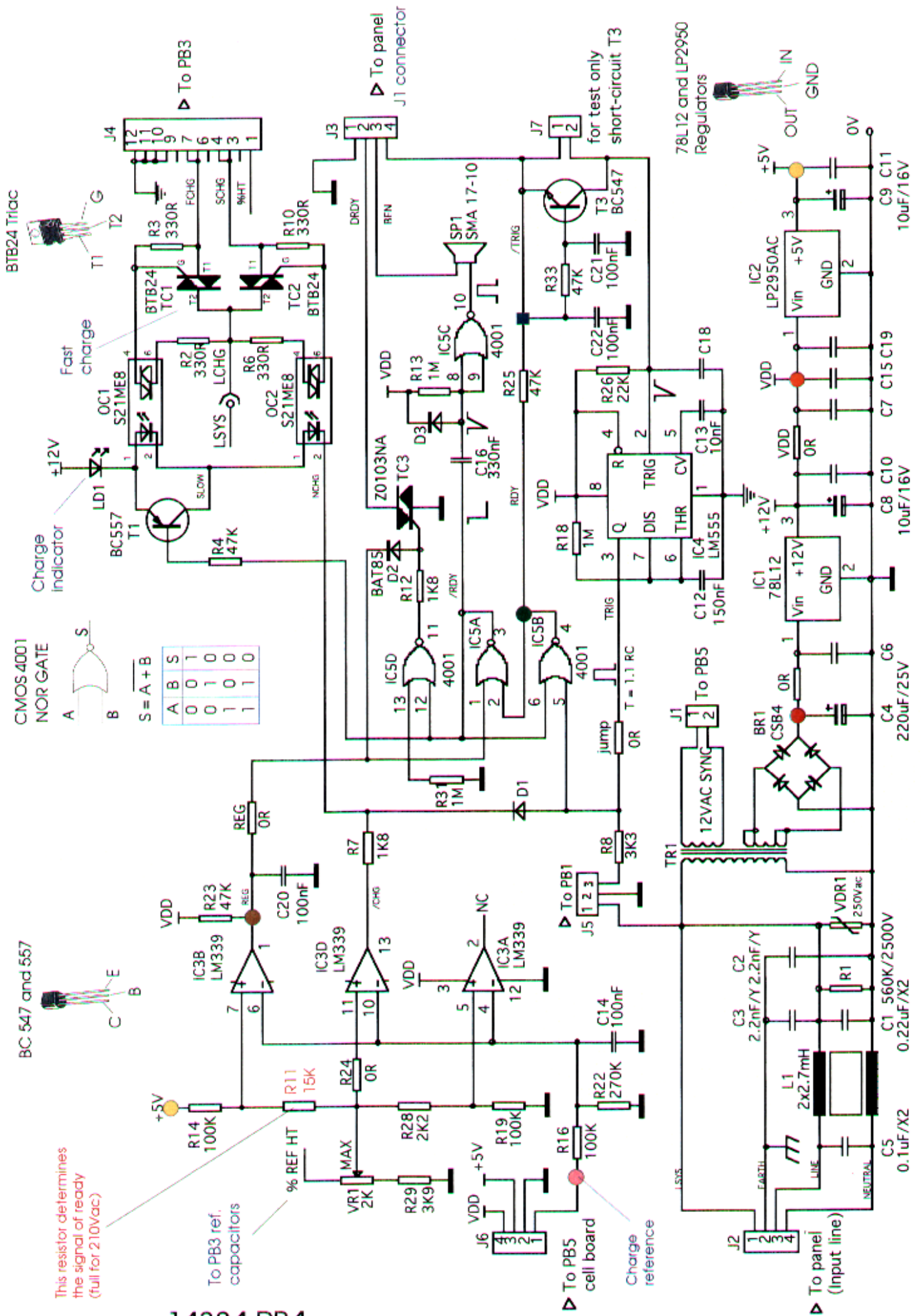

14384 PB4
 Schematic diagram for STYLE 300 and 600 (230V)

14384 PB4 - CONTROL BOARD

For STYLE 300 and 600 (230V)

Circuit de commande

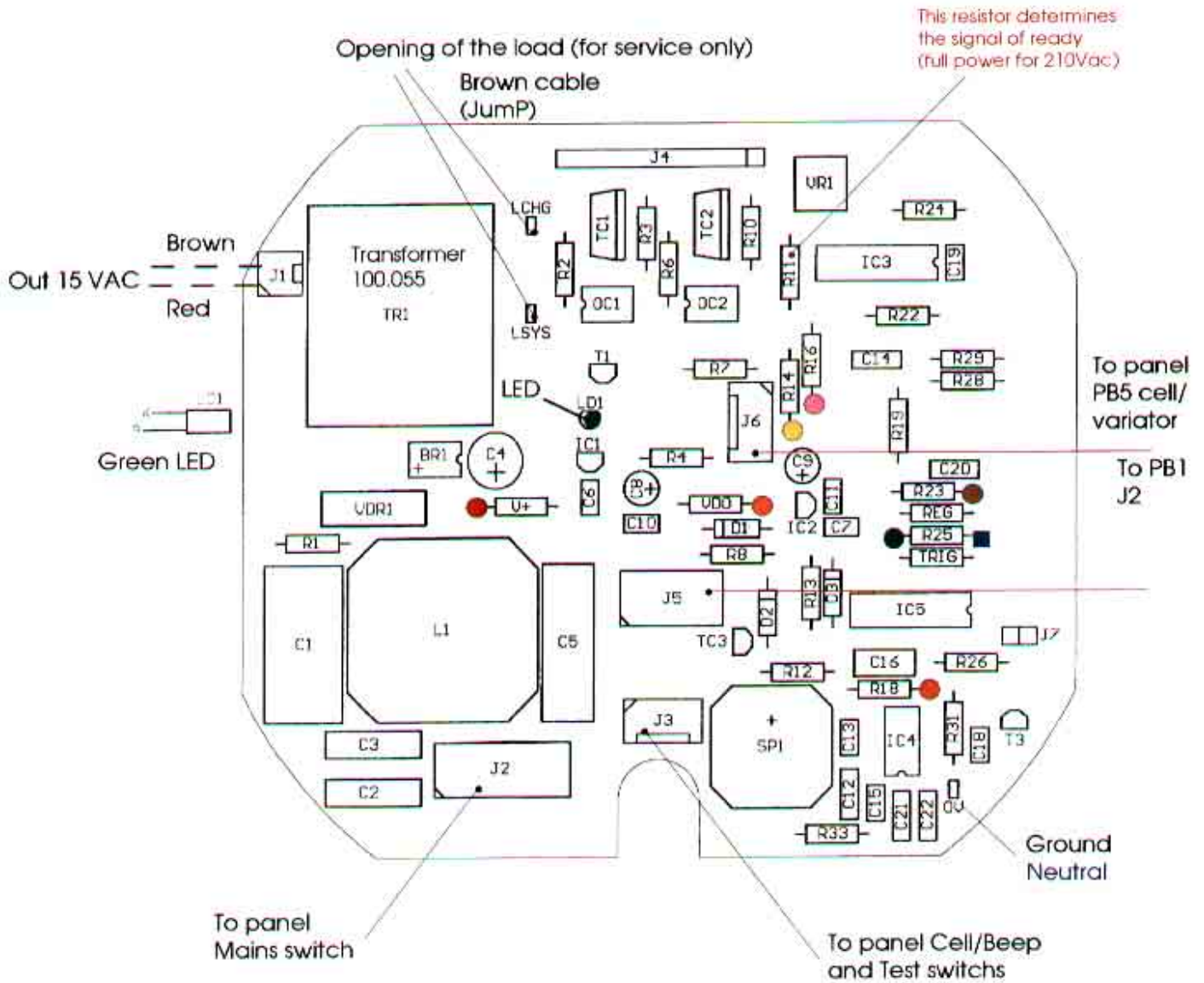

- Output + 18 V
- + 12 V (VDD)
- + 5 V
- Voltage charge Ref.
- Charge Regulation
- Trigger
- Ready

FLASH ADJUSTMENT Style 300 and 600
 1* adjust VR1 full power MAX : 595 to 600 V
 2* adjust VR2 PB5 mini power MINI : 215 V
 3* adjust VR3 PB5 medium (linearity) : 350 V
 4* verify full power

14376 PB5 Assembly For 300 S - 600 S 1200 S

SYNCRONISATION and VARIATOR FLASH/MODELLING

Part Nb	Qty	Part	Identification
104.007	2	10nF	C1 C2
104.015	4	100nF	C3 C4 C7 C8
104.029	1	10uF/16 V	C5
104.102	1	1uF/35 V	C9
105.028	1	PT361(phototransistor)	PT1
105.051	2	1N4148 diode 75 V/150mA	D1 D3
105.063	1	78L12 (12 V Regulator)	IC1
105.139	1	PC123FY (optocoupler)	OC1
105.153	1	J177	T6
109.027	1	4K7 + 470K Dual potentiometers	VR1
109.029	2	2K (trimmers)	VR2 VR3
109.030	1	200K (trimmer)	VR4
110.081	4	Contact Molex	J3
110.112	1	3pM Molex	J1
110.132	1	4pF Molex	J3
121.102	1	1K resistor	R10
121.103	2	10K resistor	R6 R8
121.104	3	100K resistor	R4 R5 R12
121.105	1	1M resistor	R1
121.223	3	22K resistor	R2 R7 R9
121.331	1	330R resistor	R3
121.471	1	470R resistor	R11
14009	1	1N4007 diode 1A/1000 V	D2
14012	3	BC547 NPN transistor	T2 T3 T4
14013	2	BC557 PNP transistor	T1 T5
14052	1	220uF/25 V	C6
14086	1	PCB nu (Printed board without elements)	
211.105	2	Vis M3 x 5 mm	VR1
501.031	1	Câble Synchro	J2
101.090	1	Fil 0.25 mm ² Bleu L = 100 mm	0V
101.140	1	Fil 0.25 mm ² Rose L = 130 mm	+5V
101.141	1	Fil 0.25 mm ² Blanc/Gris L = 115 mm	REF
101.150	1	Fil 0.25 mm ² Rouge/Noir L = 125 mm	VDD

501.049 Connector assembly

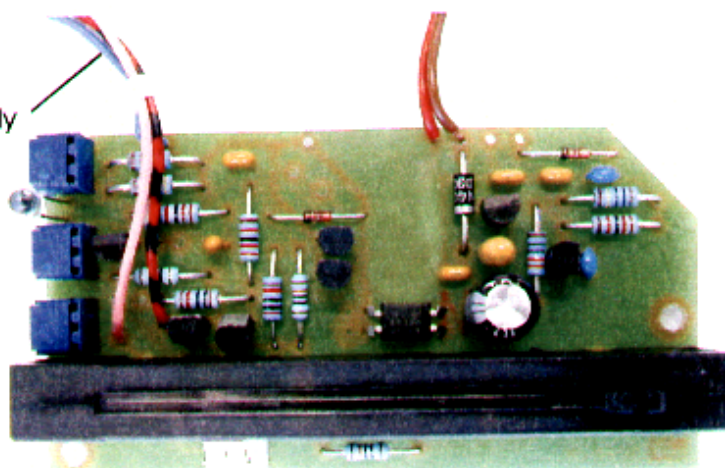

14376 PB5 Assembly for 300 S - 600 S - 1200 S

SYNCRONISATION and VARIATOR FLASH/MODELLING

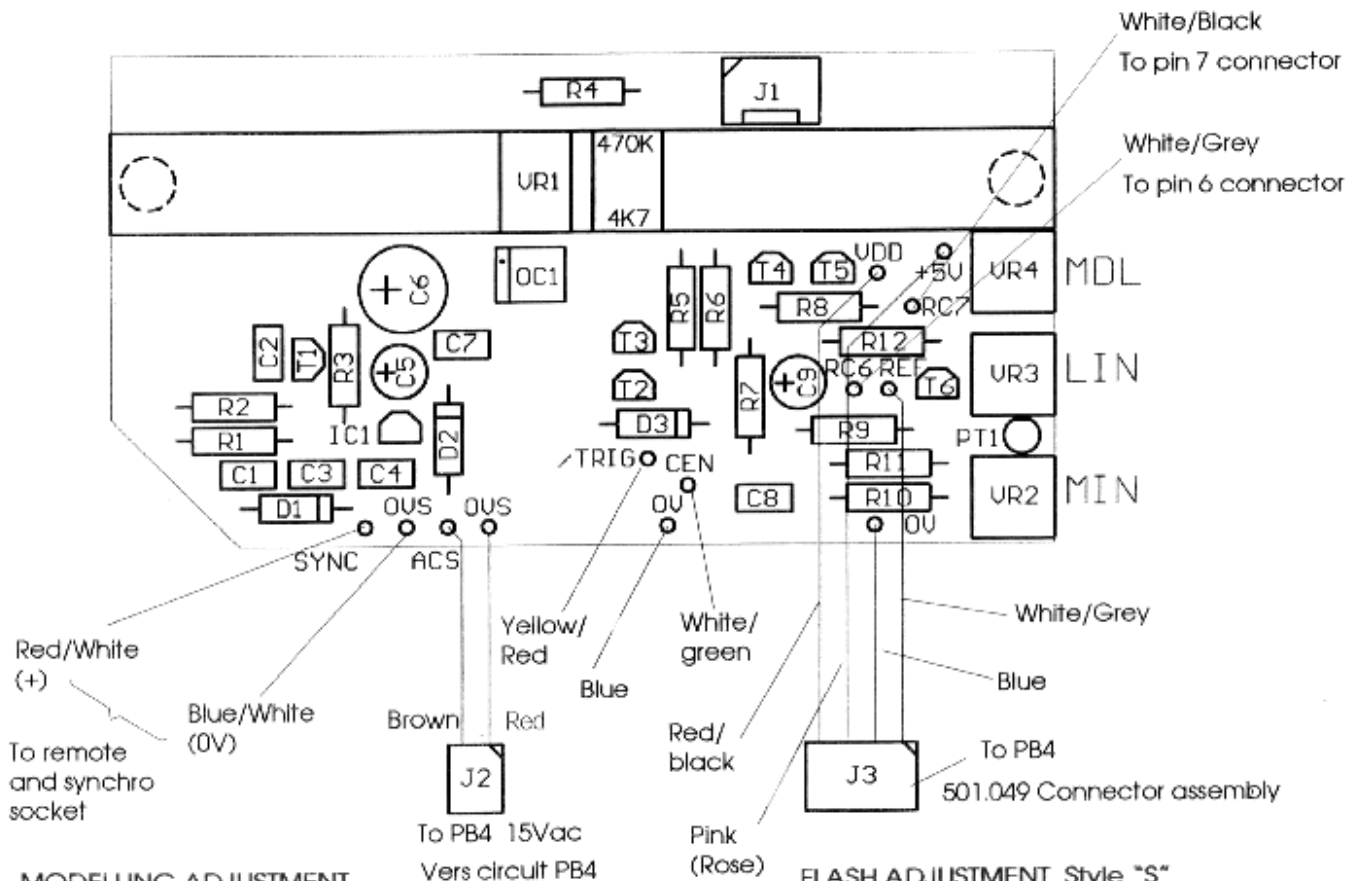
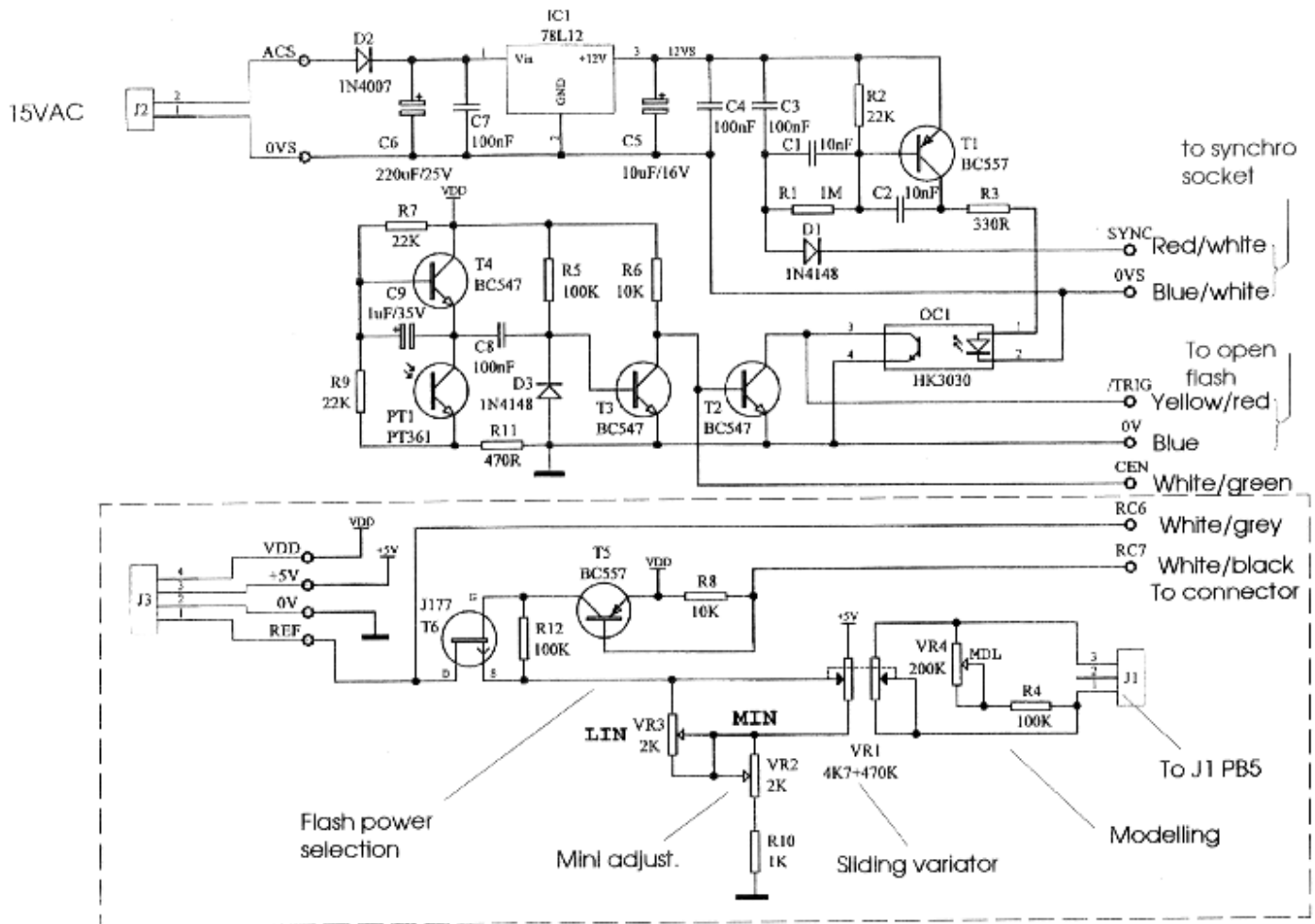

MODELLING ADJUSTMENT

Adjustment 95 VRMS at line 230 V/50Hz, between the yellow thread has the output of the fuse holder and the socket of lamp.

FLASH ADJUSTMENT Style "S"

- 1* adjust VR1(PB4) full power MAX : 595 max. 600 V
- 2* adjust VR2 (PB5) mini power MINI : 160 V
- 3* adjust VR3 (PB5) medium (linearity) : 310 V
- 4* verify full power with VR1 (PB4)

14395 PB5 Assembly For 300 and 600

SYNCRONISATION and VARIATOR FLASH/MODELLING

Part Nb	Qty	Part	Identification
104.007	2	10nF	C1 C2
104.015	4	100nF	C3 C4 C7 C8
104.029	1	10µF/16V	C5
104.102	1	1µF/35V	C9
105.028	1	PT361(optocoupler)	PT1
105.051	2	1N4148 diode (75 V/150mA)	D1 D3
105.063	1	78L12 12V Regulator	IC1
105.139	1	PC123FY (optocoupler)	OC1
105.153	1	J177	T6
109.027	1	4K7+470K Dual potentiometers	VR1
109.029	2	2K (potentiometers)	VR2 VR3
109.030	1	200K (potentiometer)	VR4
110.081	4	Contact Molex	J3
110.112	1	3pM Molex	J1
110.132	1	4pF Molex	J3
121.001	1	0R (jump)	REF
121.103	1	10K	R6
121.104	2	100K	R4 R5
121.105	1	1M	R1
121.222	1	2K2	R10
121.223	3	22K	R2 R7 R9
121.331	1	330R	R3
121.471	1	470R	R11
14009	1	1N4007 diode 1A/1000V	D2
14012	3	BC547 NPN transistor	T2 T3 T4
14013	1	BC557 PNP transistor	T1
14052	1	220µF/25 V	C6
14086	1	PCB nu (Printed board without elements)	
211.105	2	Vis M3 x 5 mm (screws)	VR1
501.031	1	Câble Synchro	J2
101.090	1	Fil 0.25 mm ² Bleu L = 100 mm	0V
101.140	1	Fil 0.25 mm ² Rose L = 130 mm	+5V
101.141	1	Fil 0.25 mm ² Blanc/Gris L = 115 mm	REF
101.150	1	Fil 0.25 mm ² Rouge/Noir L = 125 mm	VDD

14395 PB5 Assembly For 300 and 600

SYNCRONISATION and VARIATOR FLASH/MODELLING

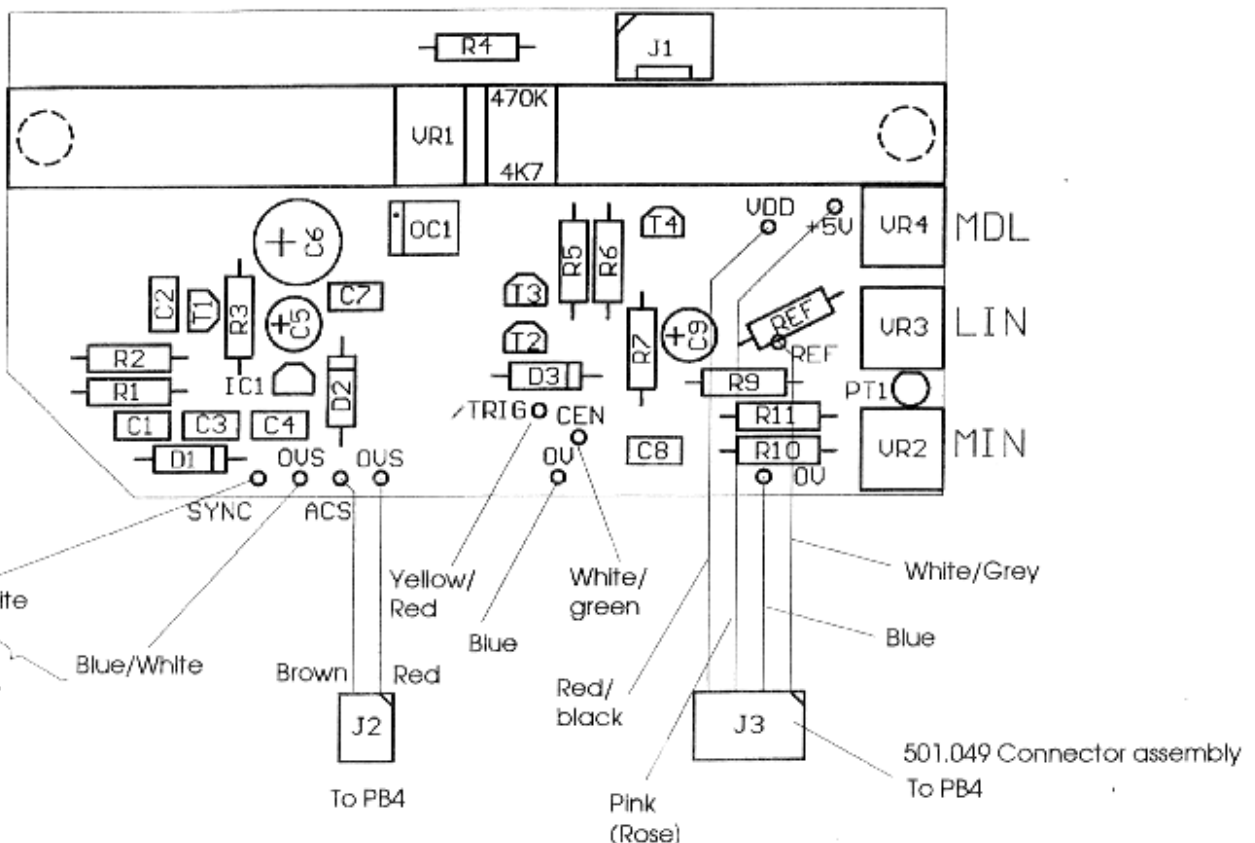
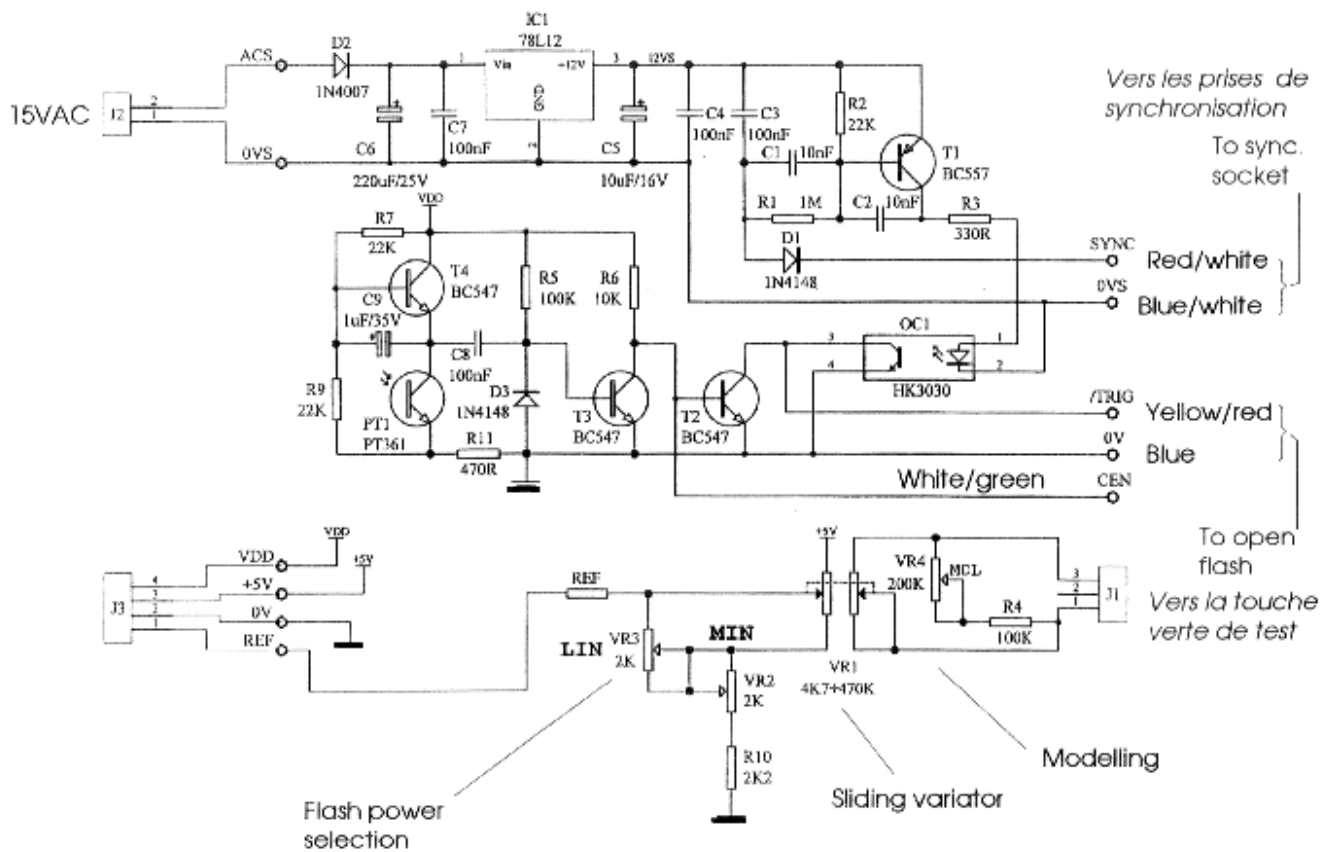

MODELLING ADJUSTMENT
 Adjustment 105 VRMS at line 230V/50Hz, between the yellow thread has the output of the fuse holder and the socket of lamp.

FLASH ADJUSTMENT Style 300 and 600 only
 1* adjust VR1 (PB4) full power MAX : 595 max 600 V
 2* adjust VR2 (PB5) mini power MINI : 215 V
 3* adjust VR3 (PB5) medium (linearity) : 350 V
 4* verify full power with VR1 (PB4)

Panel control

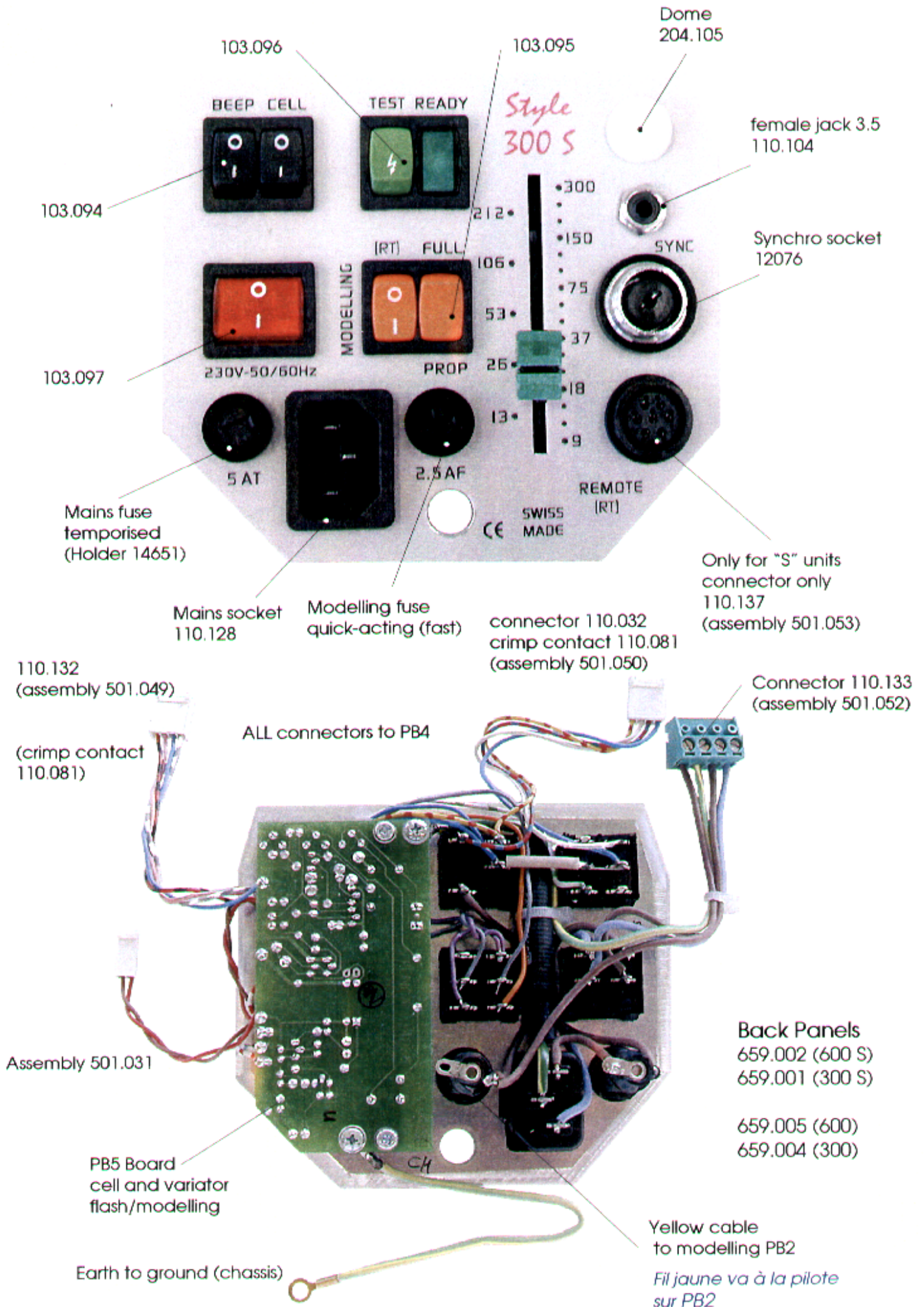

REMOTE CONTROL

Fernbedienung für Style S

Télécommande pour Style S

19328 for *Style 300 S*

19329 for *Style 600 S*

19330 for *Style 1200 S*

19331 Universal remote for all *Style*

Télécommande universelle avec plaquette exprimée en fractions (1/1 - 1/32 à la place de joules)

11085 cord 1.2 m

(Câble de liaison de 1,2 m)

11086 cord 2.4 m

11087 cord 4.8 m

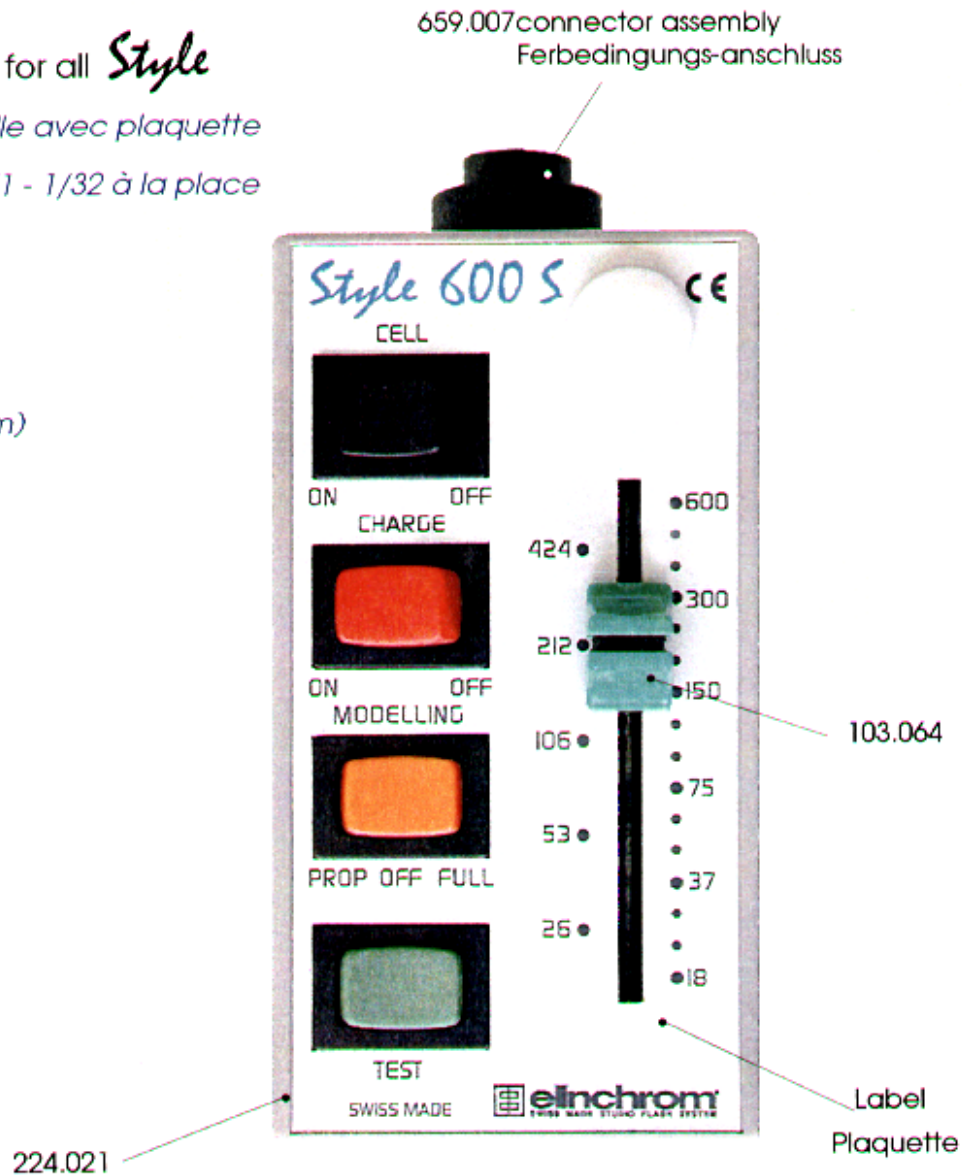

Part Nb	Qty	Part
224.021	1	Complete case (<i>boîtier complet</i>)
211.885	4	Screws KA 22 x 8 (<i>vis</i>)
659.007	1	socket assembly (<i>connecteur assemblé</i>)
103.064	1	Green button for sliding (<i>bouton vert du potentiomètre</i>)
224.200	1	Label 300 S self-adhesive (<i>plaquette autocollante</i>)
224.201	1	Label 600 S self-adhesive
224.202	1	Label 1200 S self-adhesive
224.203	1	Universal Label "self-adhesive" (universal remote)

14390 REMOTE Assembly Board

For STYLE 300S/600S/1200S (230 V and 120 V)

Part Nb	Qty	Part	Identification
103.098	1	Switch ON-ON RED	S2
103.099	1	Switch ON-ON BLACK	S3
103.100	1	Switch ON-OFF-ON ORANGE	S1
103.101	1	Switch MOM-OFF-MOM GREEN	S4
104.015	3	100nF	C1 C2 C6
104.029	2	10µF/16V	C3 C4
104.102	1	1µF/35V	C5
105.028	1	PT361 (phototransistor)	PT1
105.051	1	1N4148 diode 75V/150mA	D1
105.089	1	LP2950AC	IC1
109.023	2	2K (potentiometers)	VR3 VR4
109.027	1	4K7+470K Dual potentiometers	VR1
109.031	1	200K (potentiometer)	VR2
120.001	1	OR (jump)	JP1
121.102	1	1K	R6
121.103	1	10K	R5
121.104	2	100K	R1 R4
121.223	2	22K	R2 R3
121.471	1	470R	R7
14012	3	BC547 NPN transistor	T1 T2 T3
211.105	2	Vis M3x5 (screw)	VR1
14090	1	PCB nu (only)	

Connector only
110.138

MODELLING ADJUSTMENT

Adjustment 95 VRMS at line 230V/50Hz. between the yellow thread has the output of the fuse holder and the socket of lamp.

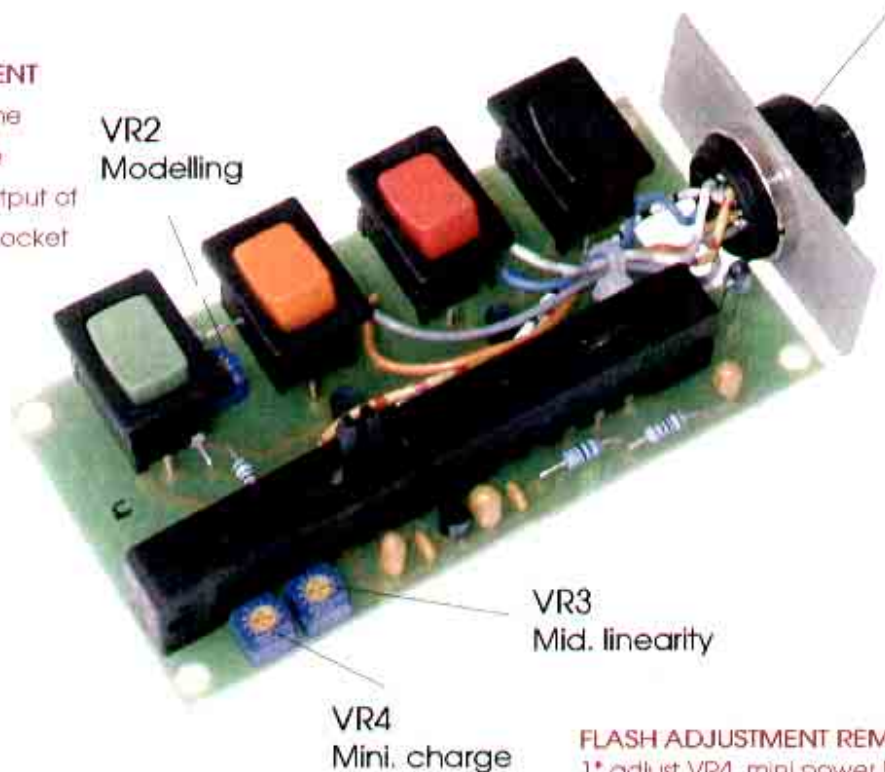

FLASH ADJUSTMENT REMOTE

1* adjust VR4 mini power MINI: 160 V
2* adjust VR3 medium (linearity): 310 V

14390 REMOTE Assembly

For STYLE 300 S/600 S/1200 S (230 V and 120 V)

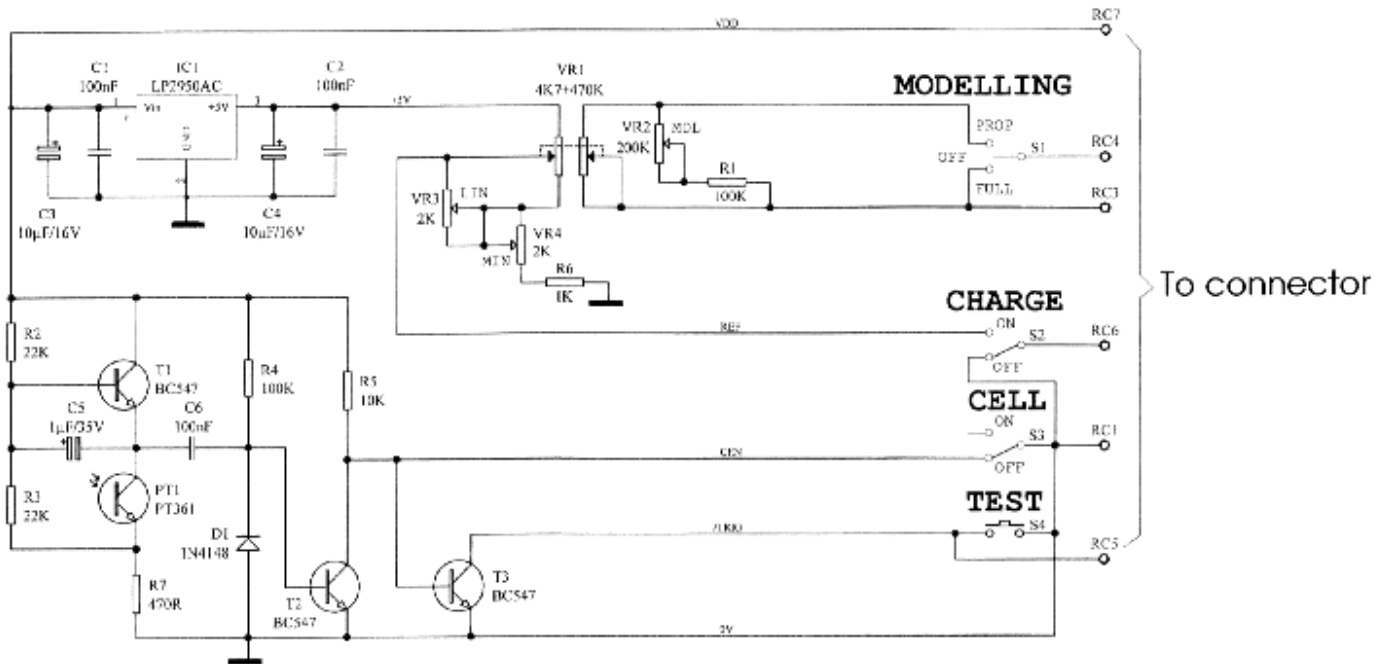

ADJUSTING THE MODELLING LIGHT

This adjustment brings the light intensity from full (1/1) down minimum (1/32) with the trimmer VR2 .

1. Measure the voltage with a voltmeter VRMS in VAC mode.
2. Modelling light selector : light ON
3. Adjustment 95 VRMS at line 230 V/50Hz, between the yellow thread has the output of the fuse holder and the socket of lamp.

JUSTIERUNG DER EINSTELLICHTS

Justierte Spannung bei mini. Leistung 95 VRMS für Netzspannung 230 VAC/50Hz.

Réglage de la pilote

Mettre au minimum de puissance au 1/32 et régler la tension à 95 VRMS à l'aide de VR2.

Le voltmètre doit être raccordé entre le fil jaune situé à la sortie du fusible pilote et l'autre conducteur de la lampe (par exemple la douille ou le fil qui vient du triac)

(sur le compact Style l'interrupteur orange doit être sur la position RT)

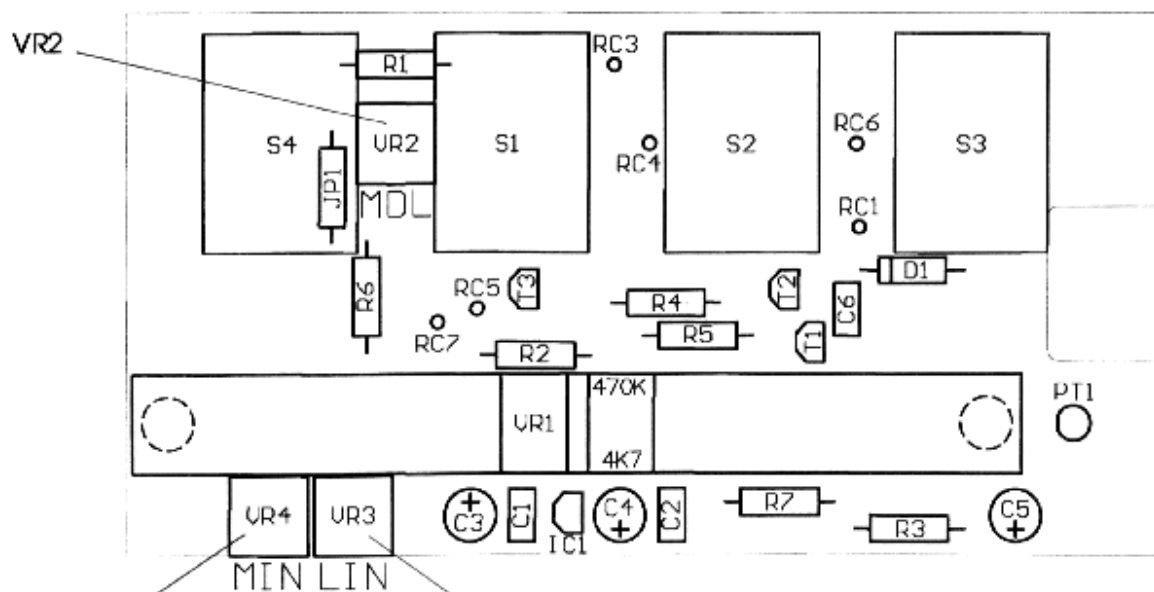

FLASH ADJUSTMENT

1* adjust VR4 mini power MINI : 160 V

2* adjust VR3 medium (linearity) : 310 V

Style 1200 S

Power 1200Ws

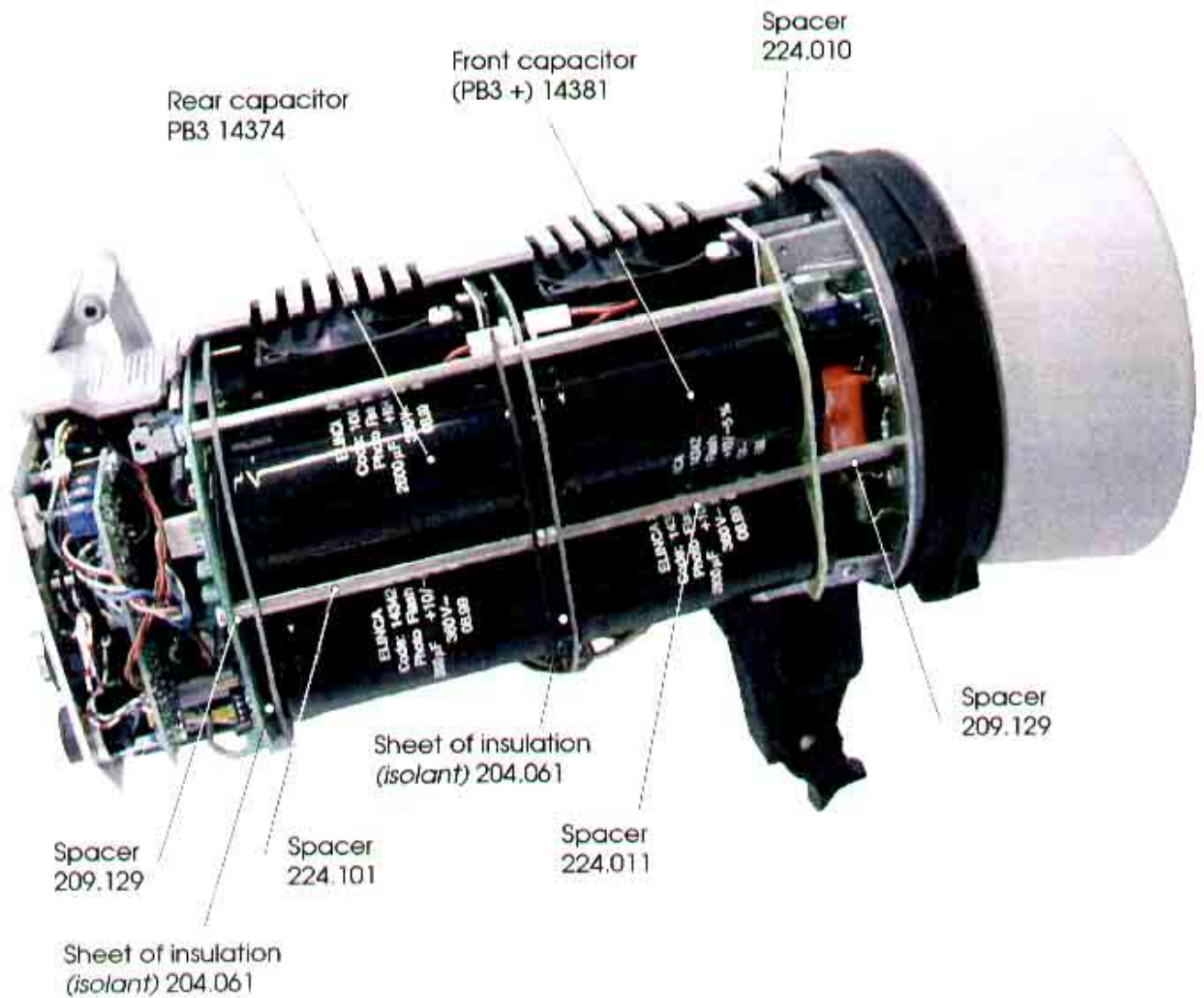

Style 1200 S

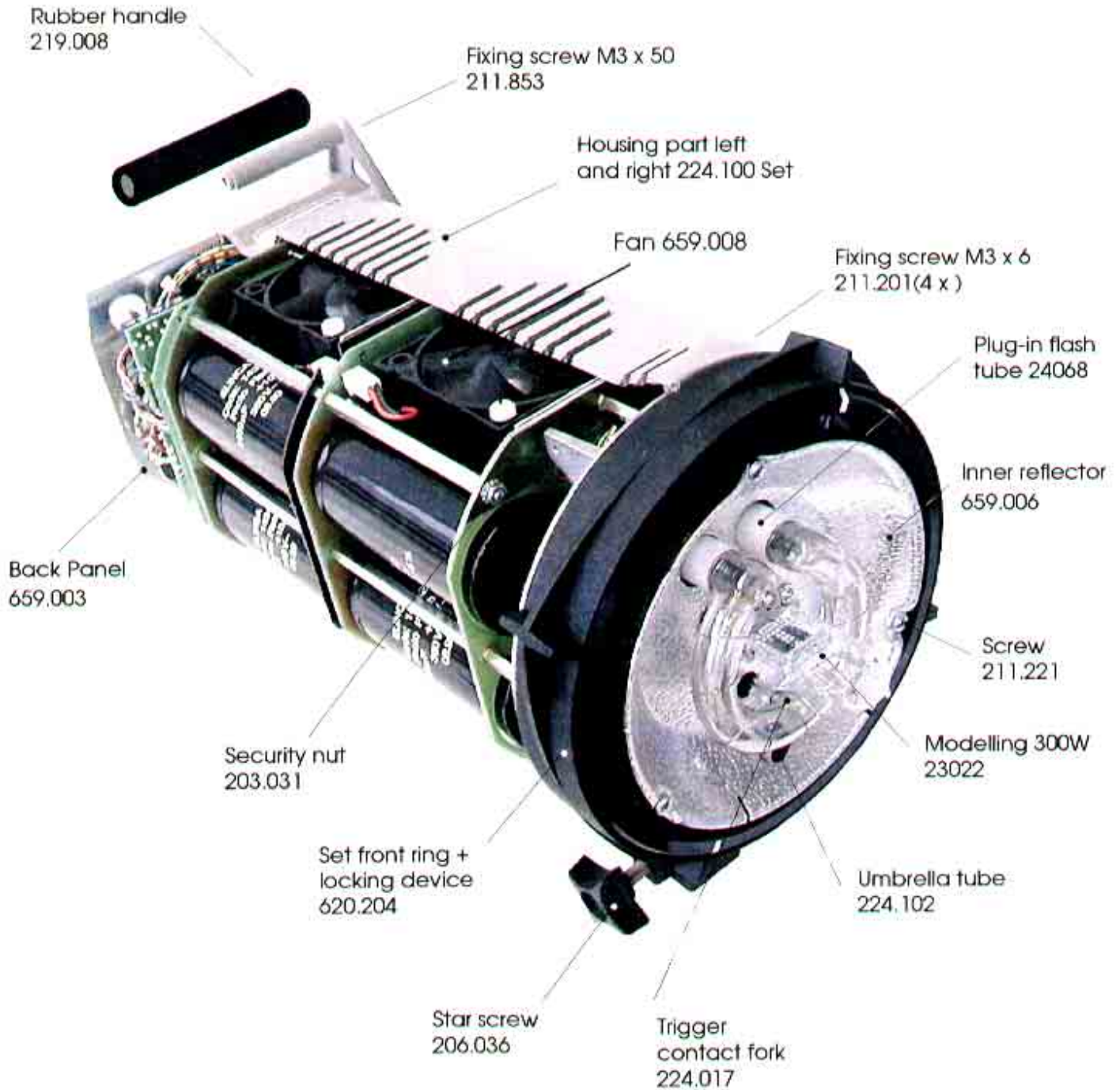

14391 PB1 Style 1200 S Assembly board
Trigger + booster and supply fan

Part Nb	Qty	Designation	Identification
100.060	1	Trigger coil ZS1052/1	TR1
104.006	1	4.7nF/500V capacitor	C2
104.007	1	1 0nF	C1
104.012	1	47nF/250 V	C5
104.017	1	100nF/400 V	C6
104.025	2	1uF/400 V	C9 C10
104.124	1	330nF/400 V	C7
105.011	1	1 N5359B (24 V/5W zener diode)	ZD1
105.057	1	CSB4 (rectifier bridge)	BR1
105.116	1	X0405NF (thyristor)	TY1
110.072	1	Fan connector	J1
110.134	1	Borne à visser 3p CSF-03001 Connector with screws	J2
111.038	1	39R/3W resistor	R4
111.065	1	1 0K/2W resistor	R3
112.056	1	Oeillet Trigger (Eyelet trigger output)	15KV
112.071	1	LP2.8 (tab 2.8 mm)	HTB
121.102	1	1K resistor	R1
121.220	1	22R resistor	R2
121.394	1	390K	R5
14009	2	1N4007 (1A/1000 V diode)	D1 D4
14053	1	330µF/50 V electrolytic capacitor	C8
500.600	1	Gaine PVC ø 6 x 50 mm (insulation)	
500.432	1	Fil 0.5 mm ² Brun L = 290 mm	LSYS
500.433	1	Fil 0.5 mm ² Bleu L = 290 mm	NSYS
500.434	1	Fil 0.5 mm ² Vert L = 290 mm	TRIG
14082a	1	PCB nu (board whitout components)	

14391 PB1 for Style 1200 S

Trigger + booster and supply fan

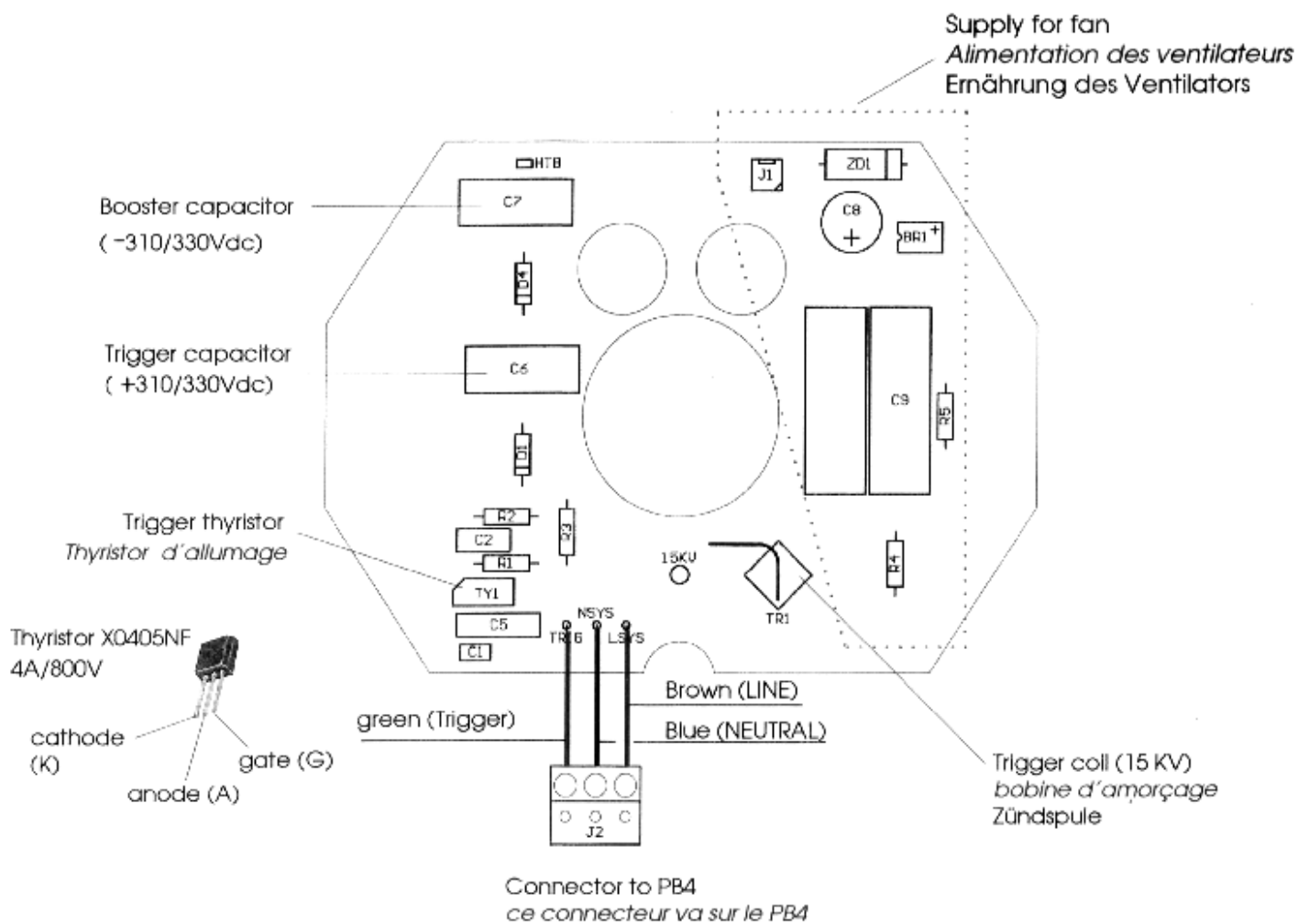
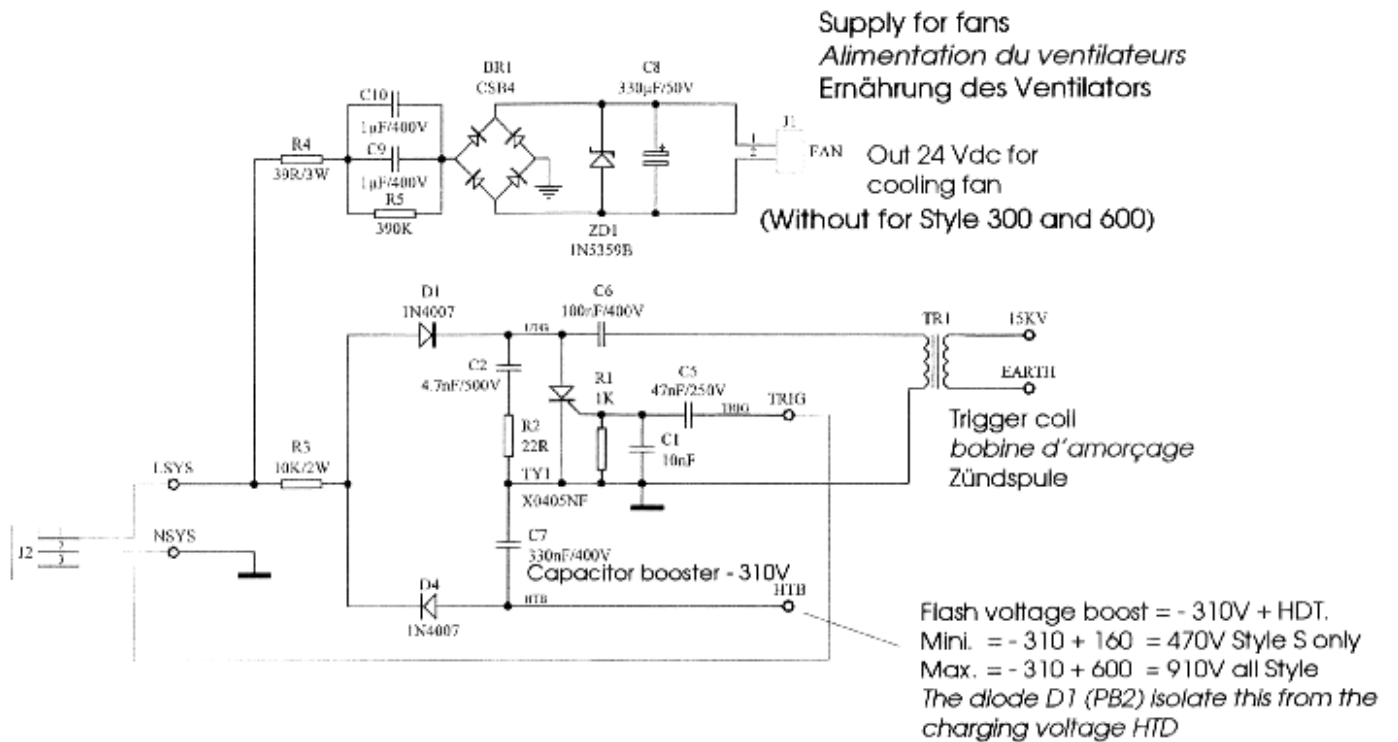

14392 PB2 for Style 1200 S

Modelling lamp and Dump (230V)

Part Nb	Qty	Part	Identification
100.047	1	1,8 mH/2.5A Self (coil)	L1
101.229	1/3	Manchon SIL 12 X 50 (insulation tube)	R4
104.013	1	47nF/X2 (capacitor)	C2
104.018	1	220nF/250 V	C1
105.006	1	13 V zener diode	ZD1
105.049	1	BTB24 triac (24A/800 V)	TC1
105.087	1	70HF80 Power diode	D1
111.524	1	3K3/25W (discharge resistor)	R4
112.070	2	Broche 1365 B (contact)	LP1
112.076	2	Cosse 2.8x0.8 (soldering lug)	J1 J2
112.101	2	Borne de fixation, tube embrochable (Terminal for Plug-In flash tube)	HT+ HT-
121.103	1	10K	R1
121.229	1	220R	R2
121.564	1	560K/2500V	R5
121.569	1	560K	R3
203.010	2	Ecrou M5 (Nut for terminal flash tube)	HT+ HT-
203.031	1	Ecrou combi M3 (Security nut)	LP1
204.128	1	Joint torique (for 100.047)	L1
209.132	2	Entretoise ø 8x5 (Spacer)	R4
210.004	2	Rondelle éventail (security washer)	HT+ HT-
210.119	1	Rondelle M6 x 0.8 (washer)	D1
211.207	1	Vis M3x20 (screw)	LP1
14015	1	32 V Diac	DD1
14032	1	100°C Thermal switch	SWTH 1
14033	1	BUZ51 or ST 4N100 Transistor Mos	T1
14083a	1	PCB nu (without elements)	
500.439	1	Fil 0.75 mm ² Noir L = 40 mm	D1
500.440	1	Fil 0.75 mm ² Rouge L =180 mm	HTD
500.441	1	Fil 0.75 mm ² Bleu L =190 mm	NSYS
500.447	1	Fil 0.5 mm ² Vert L = 240 mm	DUMP
500.448	1	Fil 0.5 mm ² Noir L = 290 mm	RMDL
500.444	1	Fil 0.5 mm ² Noir L = 40 mm	HTB
500.449	1	Fil 0.5 mm ² Rouge L = 290 mm	CMDL
500.450	1	Fil 0.5 mm ² Jaune L = 300 mm	LMDL

14392 PB2 for Style 1200 S

Modelling lamp and Dump (230V)

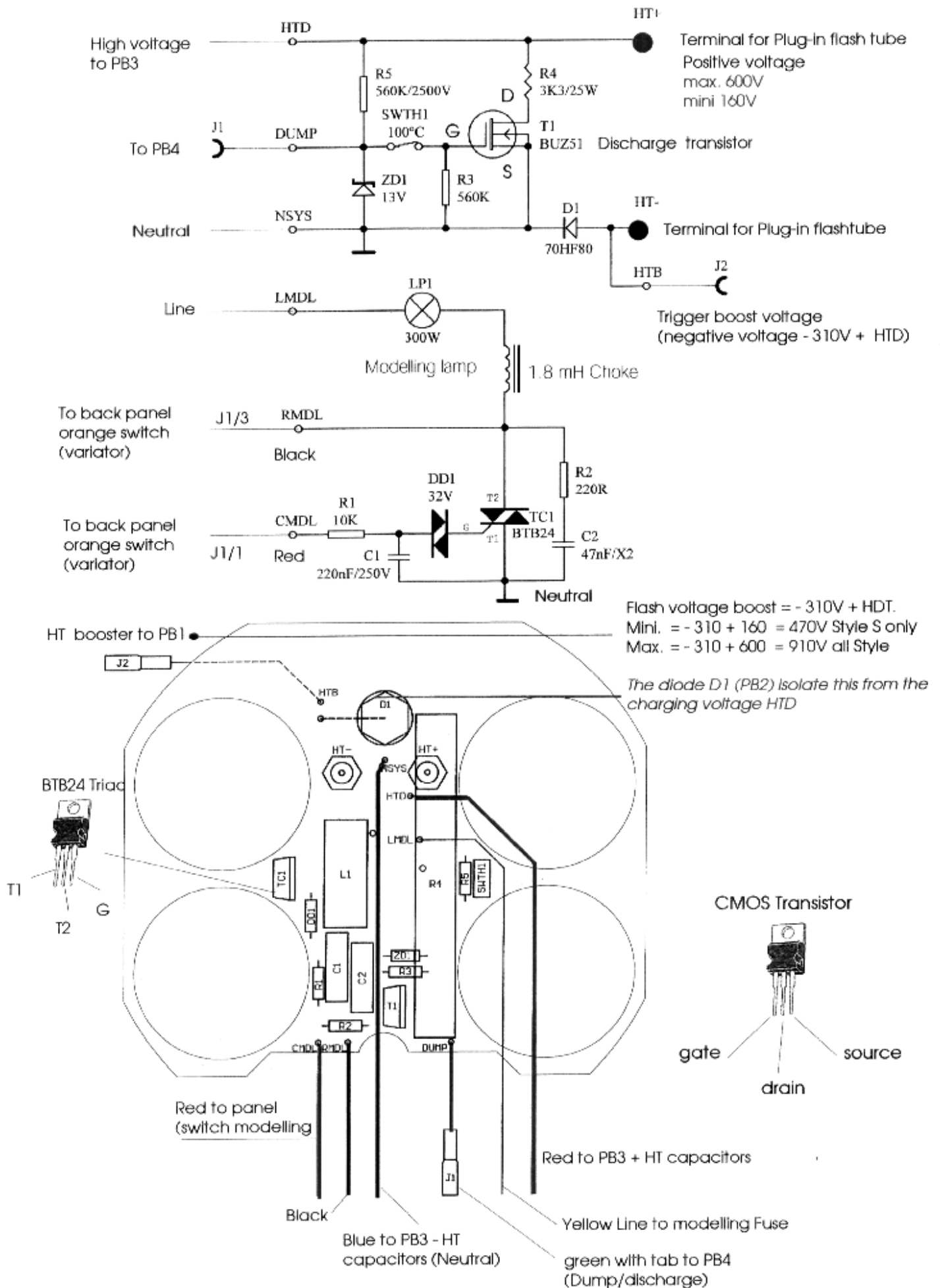

14381 PB3 + Assembly (230 V)

Front capacitors assembly for 1200 S only

Part Nb	Qty	Part	Identification
14088	1	PCB (without elements)	
14342	4	2600µF/360V (Flash capacitors)	C1 C2 C3 C4
110.130	1	1/6SL 11/240/12 Z modified (Headers/ <i>connecteur</i>)	J1
501.038	1	Cable with 2PF connector Molex L = 130 mm	J2
500.276	1	Red cable 0.75 mm ² x 150 mm	HDT
500.451	1	Blue cable 0.75 mm ² x 150 mm	NSYS
500.452	1	Black cable 0.50 mm ² x 150 mm	HT/2

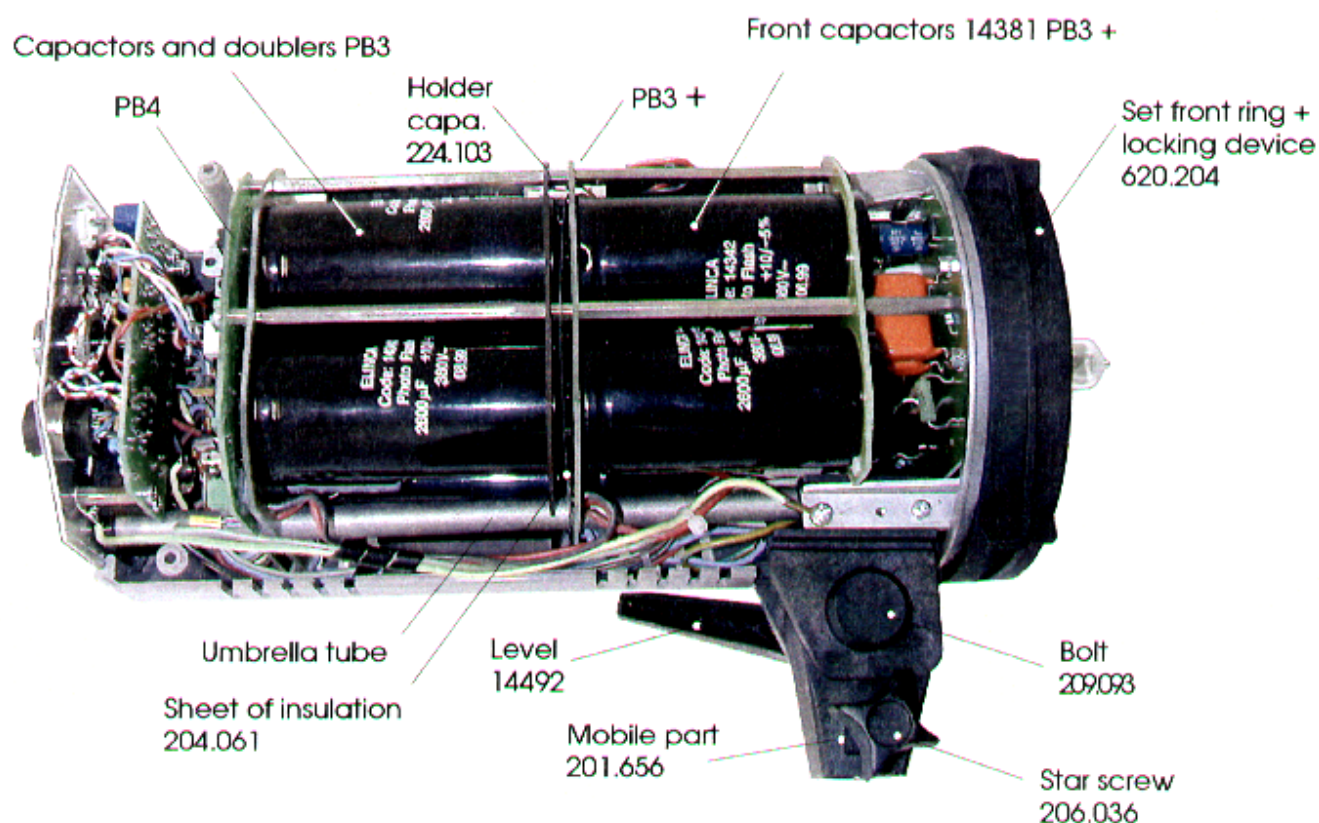

14381 PB3 + Assembly (230 V)

Front capacitors assembly for 1200 S only

Groupe frontal de condensateurs pour 1200 S

