

3000 COMBI

SERVICING MANUAL

230V60Hz VERSION

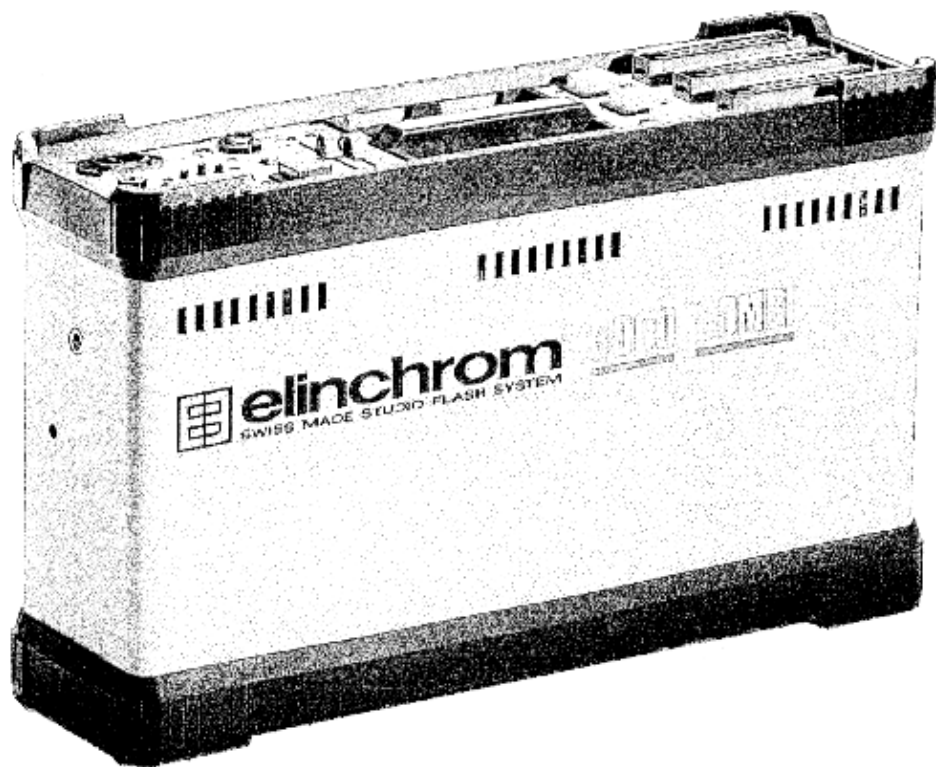

SCHEMATIC DIAGRAMS
AND PARTS LIST.

IMPORTANT ! The interior of the generator or compact contain components carrying dangerous levels of electric charge, even though the unit has been disconnected from the mains.

ALWAYS TAKE THE FOLLOWING PRECAUTIONS:

1. Always disconnect it from the mains supply, and discharge the unit before (for generator) and after (for compact) removing the outer cover or housing. This is best achieved with a suitable discharge resistor (code 11931 for 220 V) and (11930 for 110 V) fitted to a lamphead plug which may be inserted into a lamphead outlet for generator only.
For compact connect the discharge resistor in the flash tube terminals.
2. Take care when opening a generator. Always start by connecting a voltmeter across the storage capacitors, as capacitor drainage may not have occurred due to a fault in the unit.

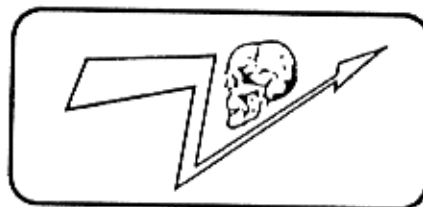

ACHTUNG GEFAHR !

Auch wenn der Generator vom Netz getrennt ist, können im Innern des Geräts noch gefährliche elektrische Spannungen vorhanden sein.

ACHTUNG GEFAEHRliche STROMSPANNUNG:

1. Bevor Sie ein Blitzgerät öffnen, entladen Sie zuerst die Kondensatoren mittels Entladewiderstand (Best, Nr. 11931 für 220 V)
2. Vorsicht beim Öffnen eines Blitzgeräts. Verbinden Sie sofort ein Voltmeter mit den Kondensatoren, denn diese könnten wegen einer anderen Panne nicht entladen sein.

ATTENTION DANGER !

Des tensions électriques dangereuses restent présentes, ceci même lorsque l'appareil est déconnecté du secteur.

PRUDENCE LORS DE L'OUVERTURE D'UN GENERATEUR OU COMPACT.

1. Déconnecter l'appareil du réseau et avant de procéder à son ouverture décharger le générateur au moyen du dispositif de décharge (code 11931 pour 220 V) et (11930 pour 110 V).
Pour les compacts retirer la poignée et la chemise métallique et procéder à la décharge en connectant le dispositif aux bornes du tube flash.
2. Commencer par vérifier la tension aux bornes des condensateurs. Leur drainage peut ne pas avoir eu lieu, la rupture d'un élément ou d'un conducteur peut en être la cause.

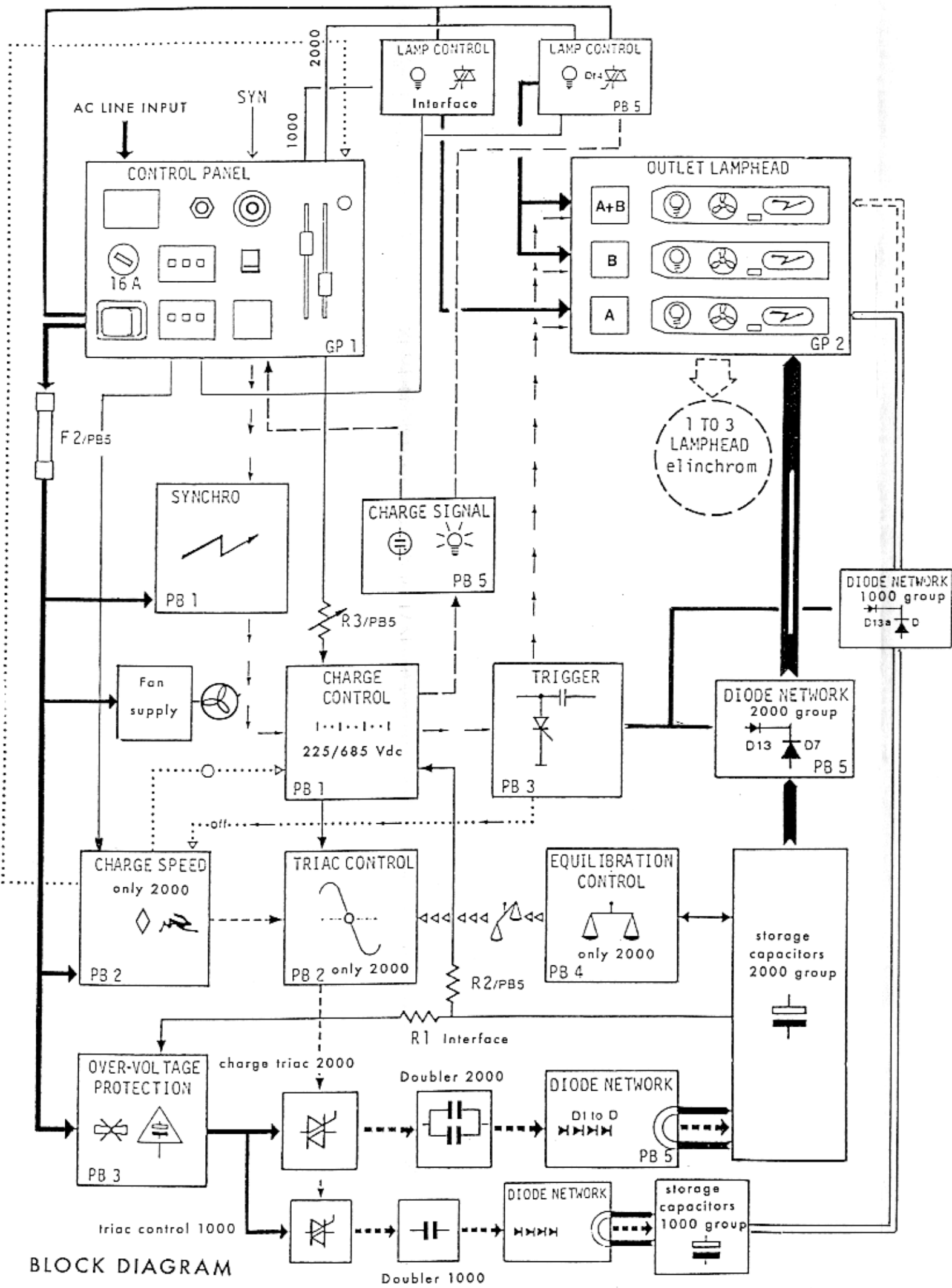

BLOCK DIAGRAM

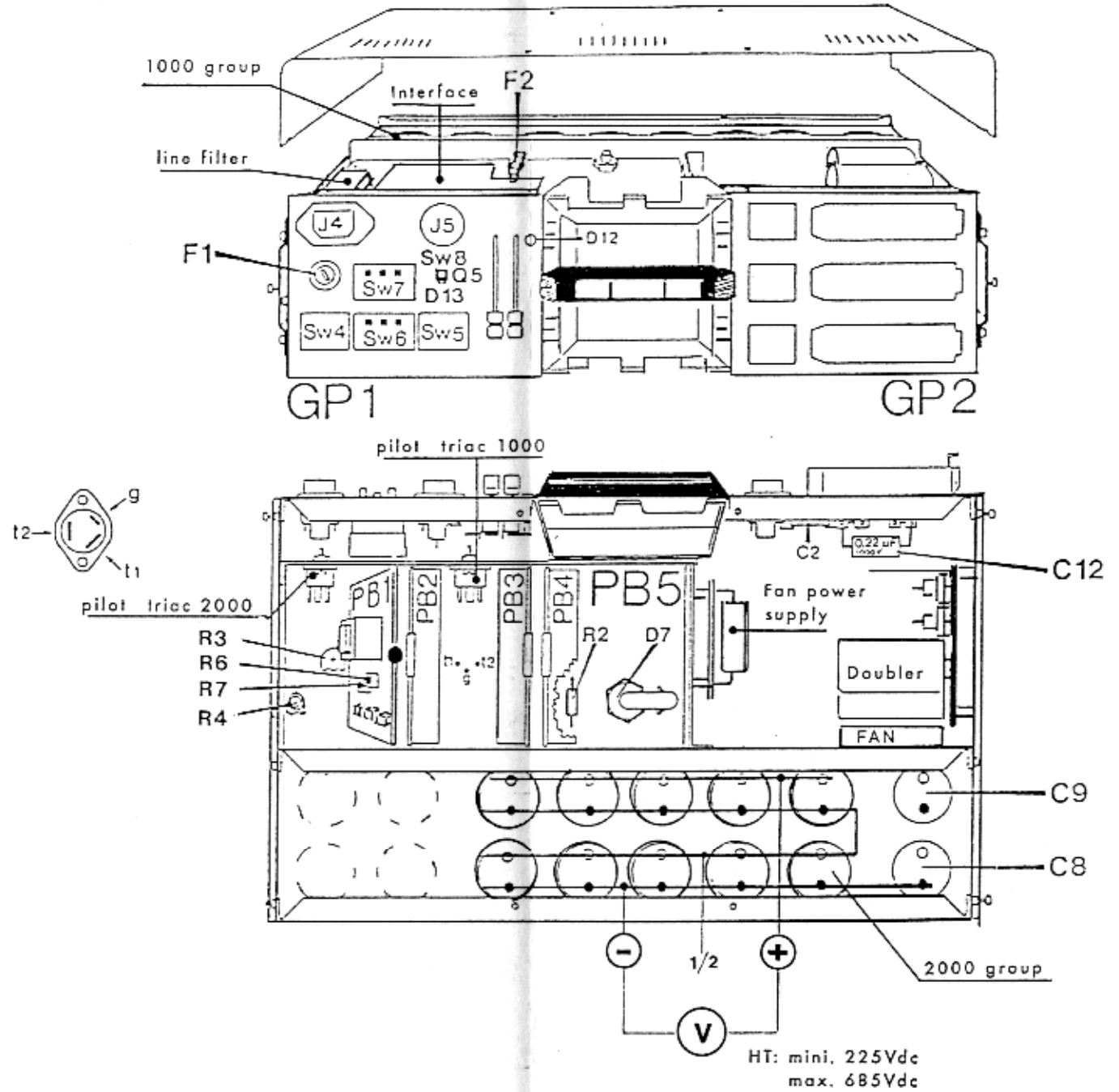

PRINTED BOARDS WITH ELEMENTS
230V/50Hz VERSION

Board	Voltage	Order
PB 1	230V	14615
PB 2	230V/50Hz	14603
PB 3	230V	14606
PB 4	115/230V	14608
PB 5	WITHOUT ELEMENT	14123C
FAN SUPPLY 230V		14618
DOUBLER 230V		14622

COMBI 3000

LOCATION OF ELEMENTS
230V/50/60Hz

DIAGRAM CONNECTION LAMPHEAD

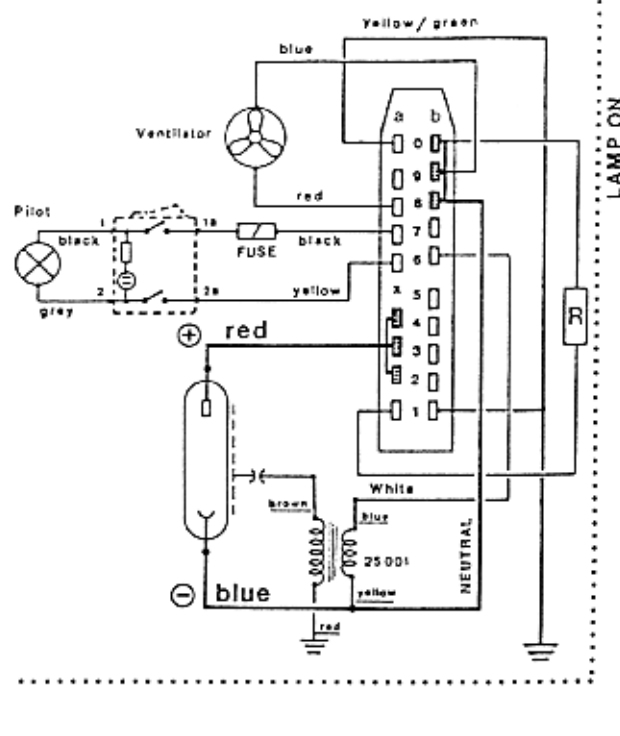

OUTLET LAMPHEAD: 1.3 (GP2)

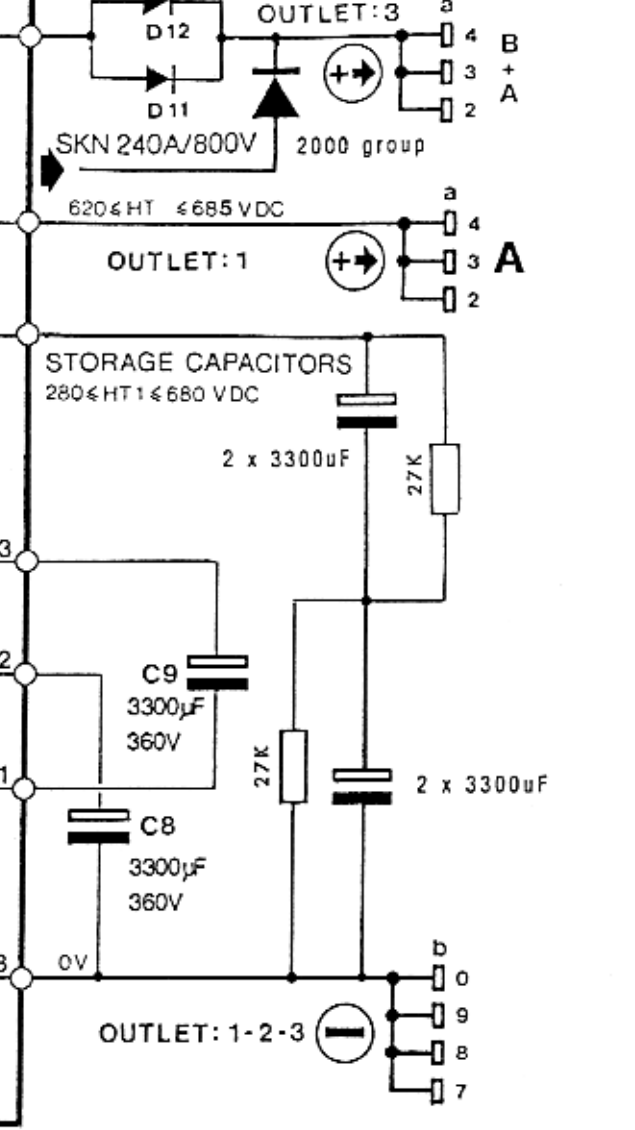
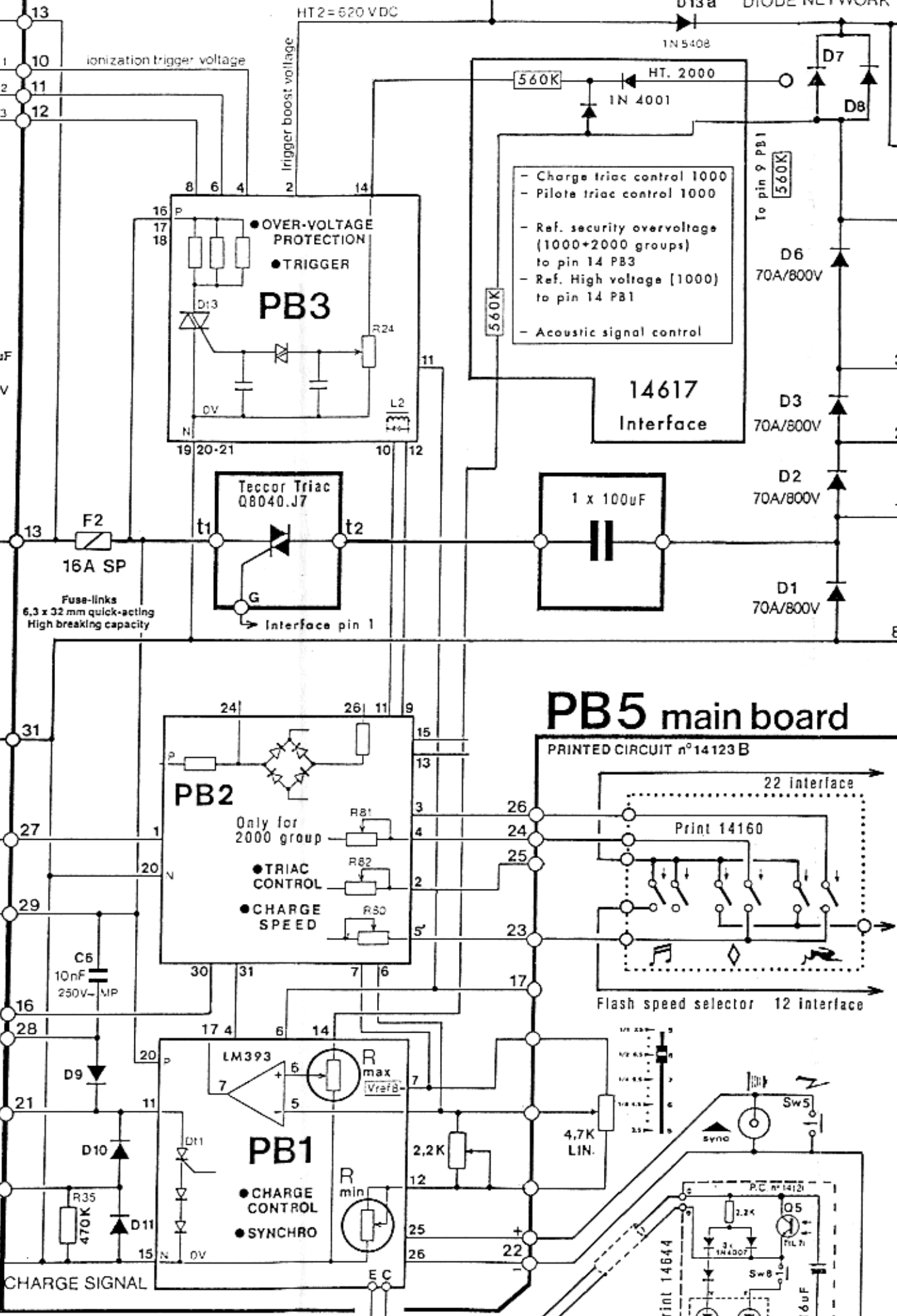
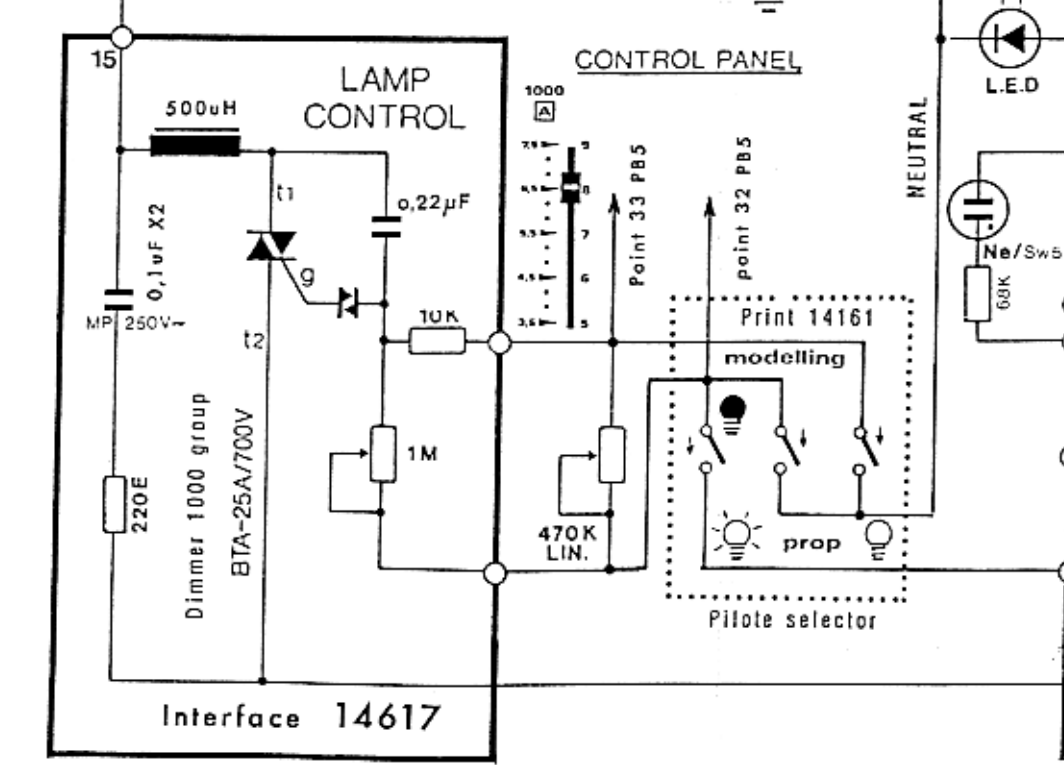
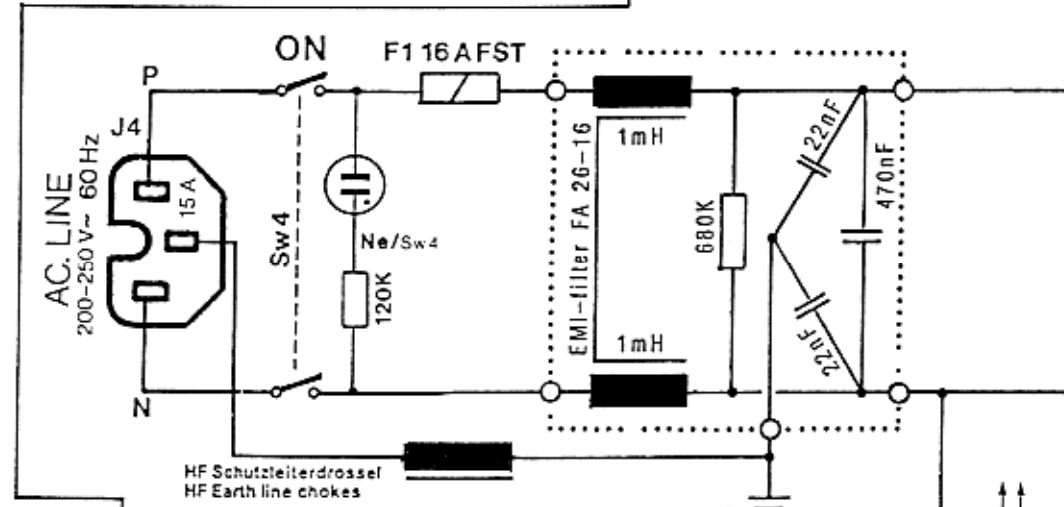
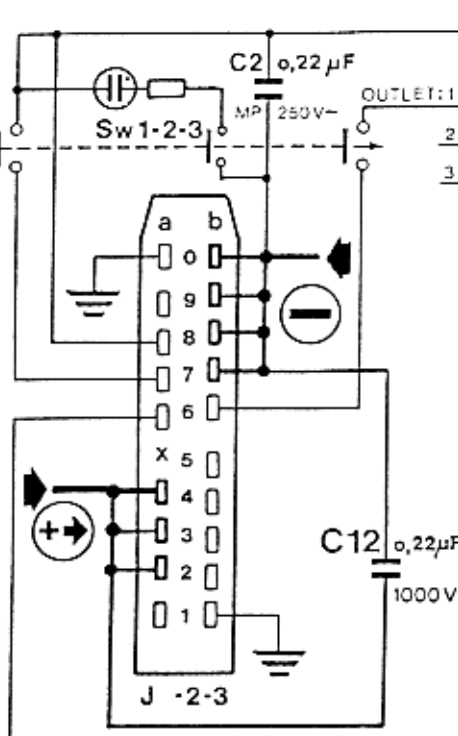

COMBI 3000
230V/60Hz VERSION
1000 group and common parts
Schematic principle

Plug-in print boards (Assembly)	14615 PB1 adjust charge (see instructions)	
	14600 PB2/60Hz	} circuit adjustments made by manufacturer
	14606 PB3	
	14608 PB4	

Charge voltage adjustment: PB1	① 1/1 adjust	PB1 685 ± 3V
	② 1/16 "	PB1 225 ± 5V
	③ 1/4 "	PB1 390 ± 5V

Pilote lampe adjustment: outlet 1 lamphead at 1/16 power (linear pot first on the control panel) adjust pot 1M on the Interface circuit for resulting voltage (53Vac) or (88 V RMS)

elinca sa 1.02.97

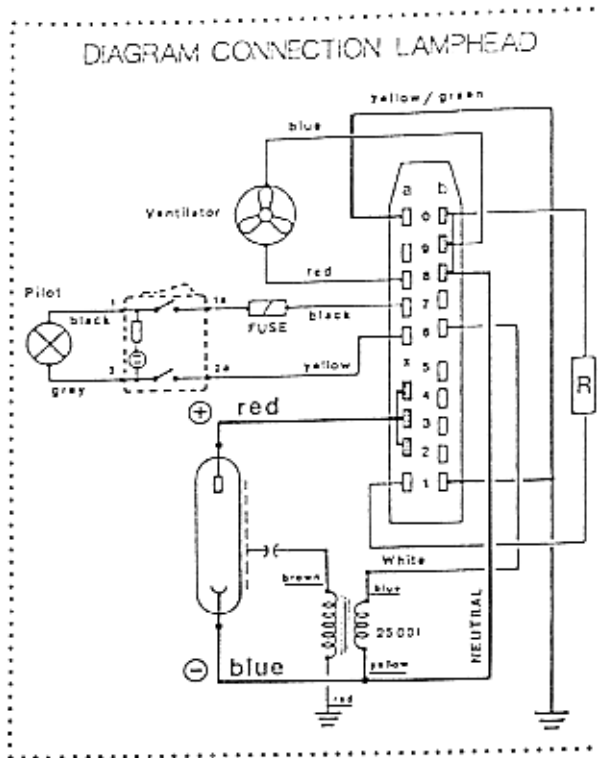

OUTLET LAMPHEAD: 2.3 (GP2)

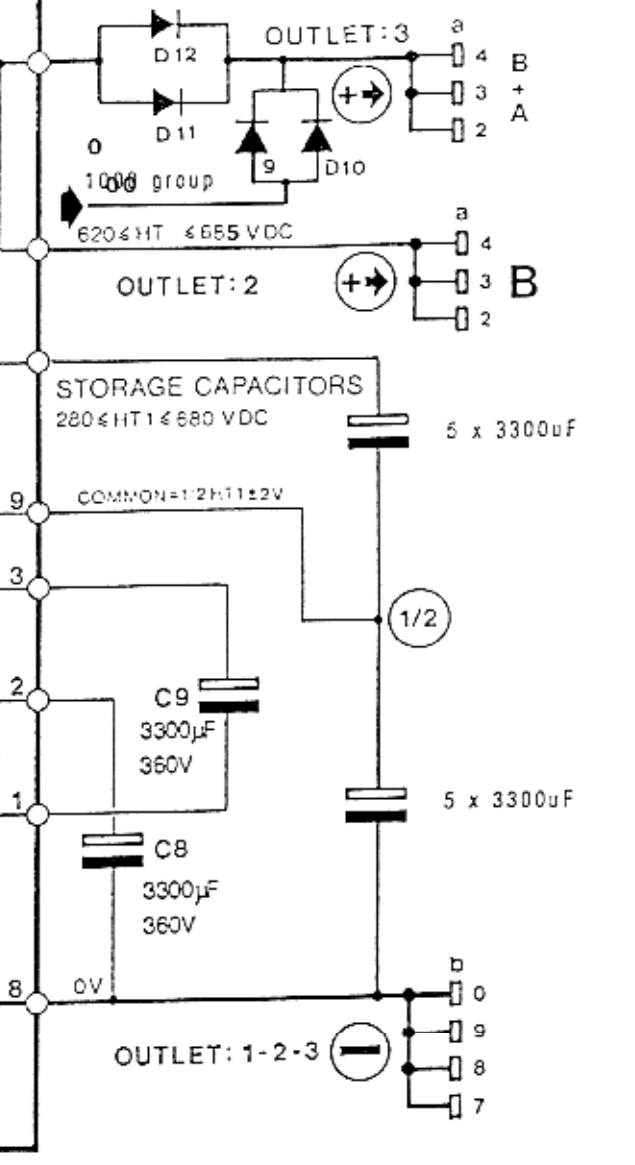
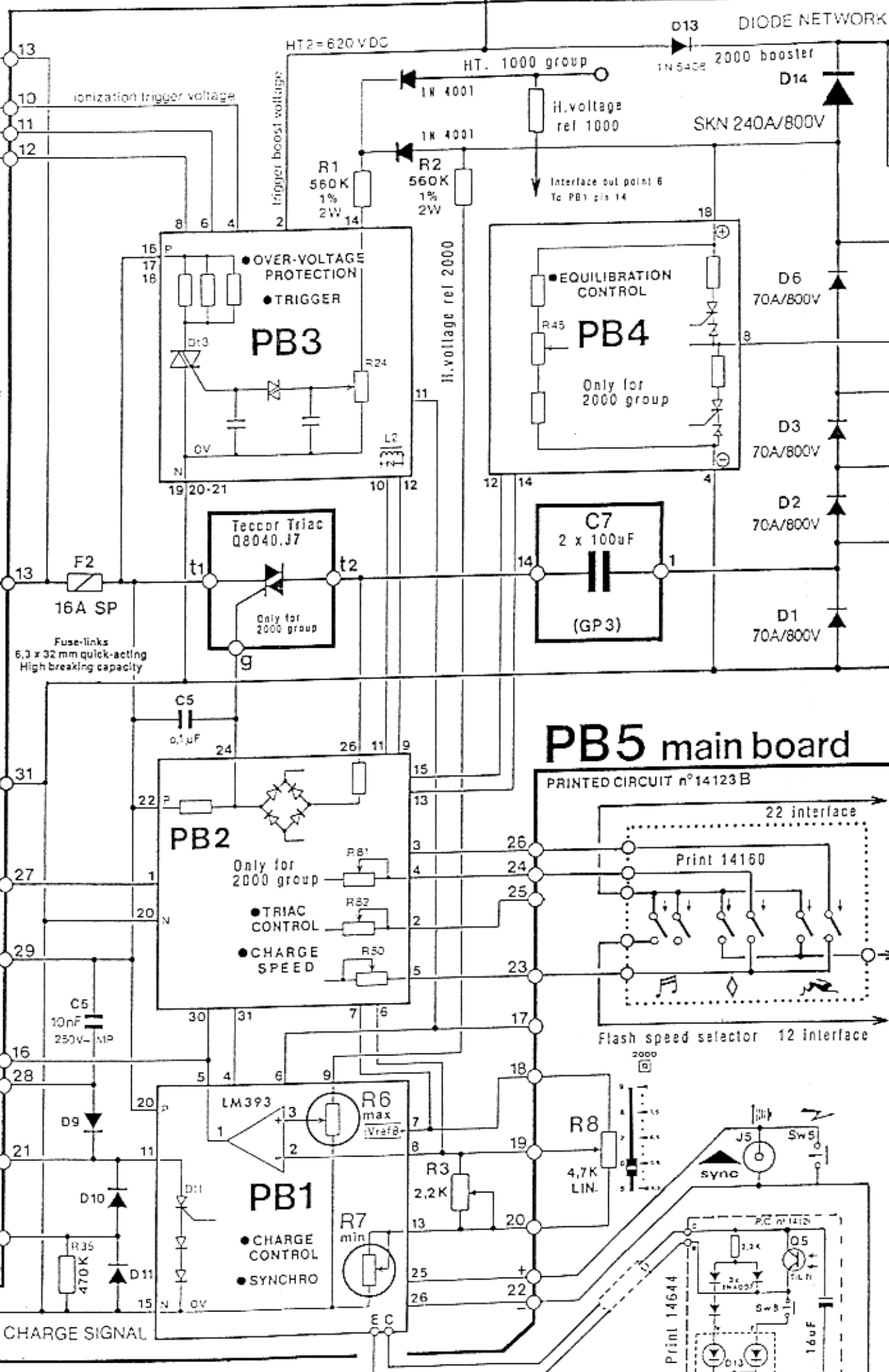
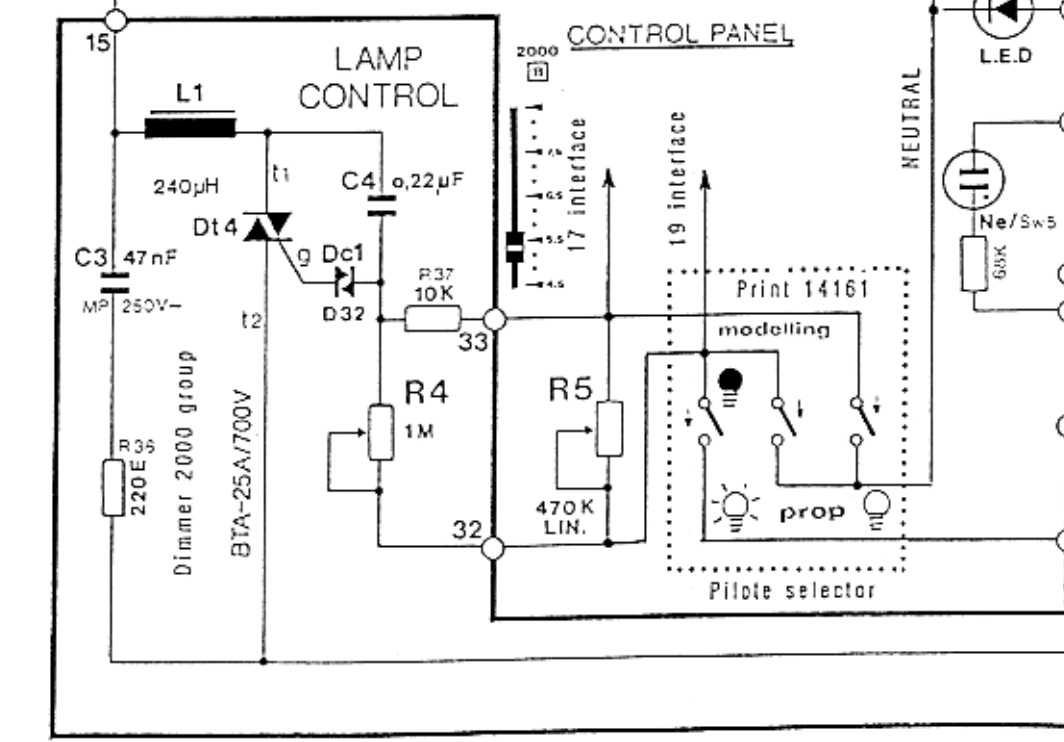
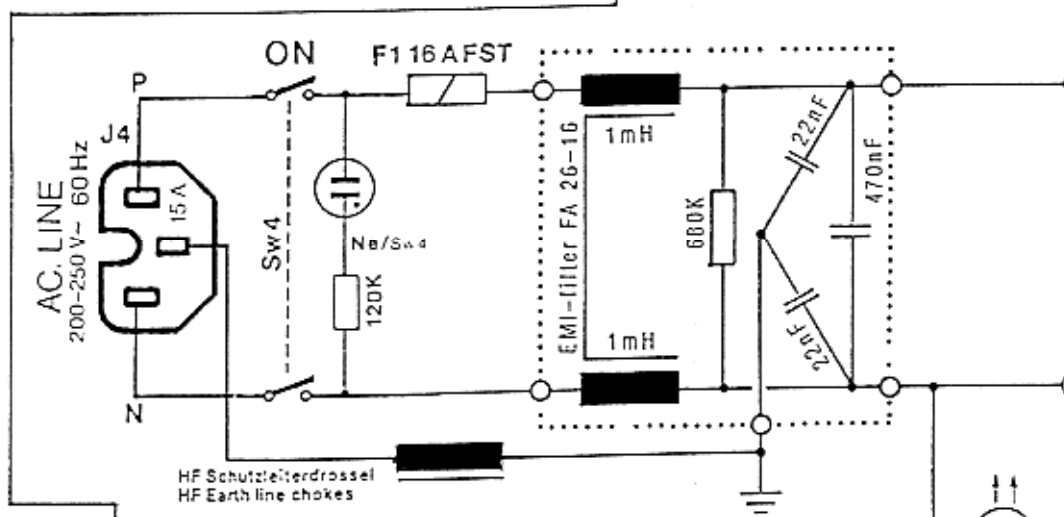
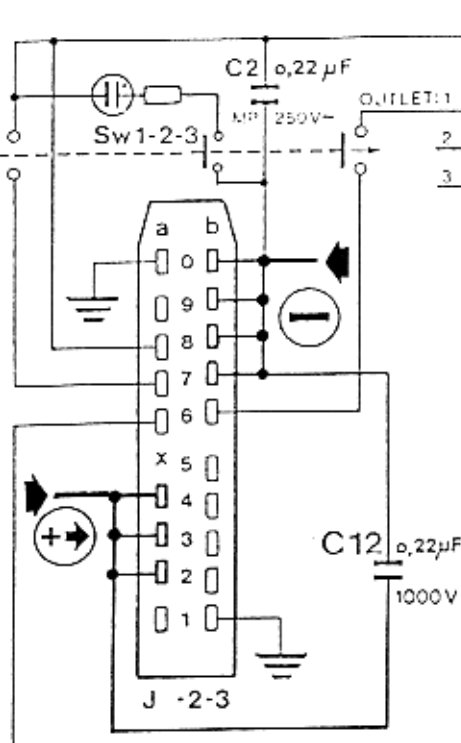

COMBI 3000

230V/60Hz VERSION

2000 group and common parts

Schematic principle

Plug-in print boards (Assembly)	14615 PB1 adjust charge (see instructions)
	14600 PB2/60Hz
	14606 PB3
	14608 PB4
	circuit adjustments made by manufacturer

Charge voltage adjustment: PB1	① 1/1 adjust R6/PB1 685 ± 3V
	② 1/16 " R7/PB1 225 ± 5V
	③ 1/4 " R3/PB5 390 ± 5V

Pilot lamp adjustment: outlet lamphead	At 1/16 power (R8 second linear pot on the control panel)
	adjust R4/PB5 for resulting voltage (53Vac) or (88V RMS)

elinca sa 1.02.97

Exchange of plug-in circuit boards

To replace a faulty board PB1, PB2, PB3 or PB4, ELINCA S.A. will supply a replacement circuit board for a lump sum.
--

This exchange system is the basis of a rationalised and straightforward rapid servicing by saving you cumbersome trouble tracing.

The low price charged for each exchange board is fixed to encourage you to utilise this system which also provides us with a precise analysis of faults arising, and helps us to eliminate sources of such faults in manufacture.

In practice this works as follows : the agency stocks the circuits with other spare parts. The faulty circuit is sent back to Switzerland in a "small packet" envelope. ELINCA S.A. in turn sends a replacement circuit in the same way and invoices it at a special low price, this as long as the returned faulty circuit board has not suffered further damages by an attempted repair which might have ruined it.

Note :

ELINCA S.A. reserves the right to invoice at full price the exchange of circuits which appear to be badly repaired and obviously incomplete.

Charging speeds

These are selected by interrupting the circuit of the charge control triac. These interruptions are governed by the "CHARGE SPEED" circuit (PB2) which acts by cutting out the control circuit of the "TRIAC CONTROL" (PB2), according to the selected charging speed:

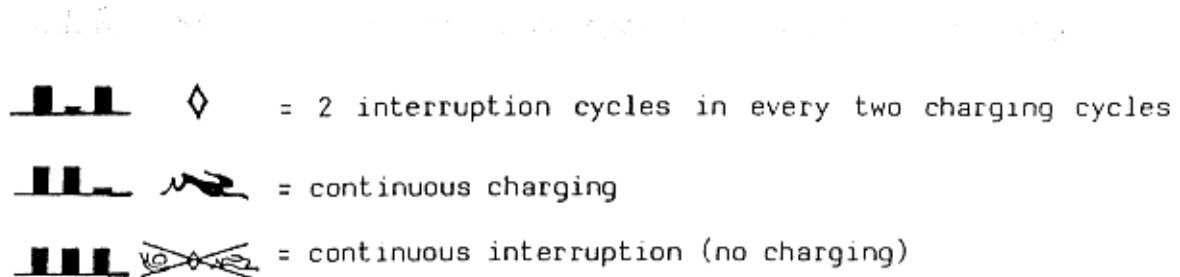

Automatic capacitor forming charge

Each time the supply is cut off - until a flash has been triggered - the "CHARGE SPEED" circuit (PB2) is in a state of slow charging : several interruption cycles to each charge cycle.

These interruptions can be prolonged if the state of the storage capacitors leads to a significant unbalance

In addition to the reduced rate charge state, a further effect at the points 7 and 8 of the "CHARGE CONTROL" circuit PB1 cancels any resistance of the intensity variator (2000). This effect ensures a full charge.

The LED (D12/GP1) signals this first charge from the moment the effect above is engaged.

Overvoltage protection

A fault in the charging system could cause a charge voltage increase which may reach 1200 volts DC in the model or 900 volts DC in the 110 volt version. This could seriously damage the unit.

The overvoltage protection circuit (PB3) is activated at a preset charge limit level.

the HT1 limit is 745 volts DC. This circuit blows the quick-blow SP cartridge fuse (F2/PB5) which is connected in series with the switching triac (Dt2), thus cutting out the charging sequence.

Equilibration (balance) check Circuit PB4

One or more faulty capacitors (not formed of one or both storage capacitor groups (C10 and C11/GP4) LEADS TO UNBALANCE in the voltage of the two groups.

First function



Restoring voltage equilibrium (balance) between the capacitor groups C10 and C11 (C10 and C11/GP4)

Each deviation is instantly compensated by switching a compensation resistor (12K) into the circuit in parallel with the group of the higher voltage.

This results in limiting the voltage deviation to the reaction limit of the circuit, i.e. about 4 to 5 volts deviation.

Example : With maximum charge selected :
HT1 = 680 volts DC. Reaction voltages to lack of balance maintain :
- either C10 at 337 volts DC and C11 at 343 volts DC,
- or the other way around.

Second function

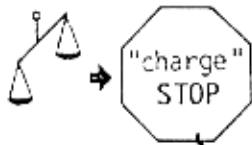

Stopping the charge when the difference in voltage between C10 and C11 increases.

This switching off takes place when the difference in voltages exceeds about 50 volts (depending on circuit tolerances the response is between 30 and 70 volts).

CAUSES OF APPRECIABLE VOLTAGE DIFFERENCES

- 1) Any considerable lack of formation of the capacitors causes an internal resistance difference between capacitor groups C10 and C11 greater than the compensation resistance (12K). The switch-off interval is the longer, the more significant the formation.
- 2) Faulty capacitors. A defective capacitor (sometimes short-circuited) rapidly produces a resistance difference between C10 and C11 greater than 12K. In this case, the cutout prevents the total charge voltage HT1 - which would tend to be applied to the sound capacitor groups - from damaging these capacitors by overvoltage.

Charge/discharge cycles

A charging cycle command sent to the "CHARGE CONTROL" circuit (PB1) switches on the "TRIAC CONTROL" (PB2) circuit as long as the selected charge level has not been reached. The "TRIAC CONTROL" circuit controls the charge triac 2000, switching it at the zero voltage crossing.

Once the charge level selected by the sliding potentiometer control (R8/GP1) is reached a new selected lower setting does not reduce the charge. To obtain the lower charge, a flash must be fired first.

The "SYNCHRO" circuit (PB1) is activated by pressing the green key (Sw5/GP1), by short-circuiting the synchro socket (J5/GP1) or by a flash striking on the photocell (Q5/GP1).

By an autocoupling system the "SYNCHRO" circuit triggers a 300 millisecond delay in the "CHARGE CONTROL" circuit (PB1), stopping the charging function and in turn activating the "TRIGGER" circuit (PB3). The discharge of the 1 μ F capacitor of the "TRIGGER" circuit across the triggering coils of the lamp units produces a 15 kV pulse which ionises the gas in the flash tubes. This creates a low-impedance discharge path for the energy stored in the storage capacitors (GP4), leading eventually to a luminous flash accompanied by a heat discharge.

Duration of synchronisation sequence :

- 80-100 microseconds to the beginning of the flash

Flash duration (t 0,1) :

- 3-15 milliseconds, depending on the generator and the number and type of lamp heads connected.

Maximum ionisation period of the tubes used by ELINCA :

- 200 milliseconds.

After the 300 millisecond delay the charging cycle can restart.

Flash trigger boost

Whatever the charging voltage (HT1) it is assumed that a sufficient voltage (HT3) is always applied to the terminals of the flash tubes.

The application of a 15 KV pulse to the triggering coil ionises the xenon tubes. The discharge of the energy through the low-impedance path thus produced is propped up by the voltage applied to the flash tube electrodes.

The "TRIGGER" circuit (PB3) produces a voltage HT2 of 620 volts DC. Two diodes D7 and D8 (see Fig 3 or 4, "DIODE NETWORK" (PB5) isolate this from the charging voltage (HT1).

The result is that the entire discharge energy goes through the diode D7 which is of suitable capacity for the purpose. Hence the voltage (HT3) has the higher value of the two voltages (HT1) and (HT2).

Special features :

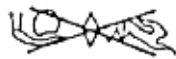

WHEN THE CHARGING CIRCUIT IS SWITCHED OFF (no setting selected at Sw7/GP1) ONLY THE TRIGGER BOOST ENERGY (0,2 joule) IS APPLIED TO THE FLASH TUBE.

controlling this boost system or the flash tubes.

Modelling light 2000

The modelling light is controlled by a triac 2000 OUT OF PHASE.

The "LAMP CONTROL" circuit (PB5) regulates the phasing as a function of the selected power level. The bottom point of the adjustment range (1/8) is adjusted by the potentiometer (R4/PB5). The intermediate settings then depend on the capacity of the capacitor (C4/PB5) which controls the linearity of the sliding potentiometer or variator (R5/GP1).

Charge signal

The charge signal given by the brief reduction of the light intensity of the modelling light is produced by partly cutting off one of the two half periods.

This is done via the "CHARGE SIGNAL" circuit (PB5) every time the "CHARGE CONTROL" circuit (PB1) receives a control signal to switch the charge.

This last function at the same time controls the ready light signal (Sw5/GP1).

CHARGE SYSTEM PRINCIPLE

- CHARGE SYSTEM
- DOUBLER/DIODE NETWORK
- CAPACITORS BANK

COMBI 3000 (230V/50/60Hz) DOUBLER/DIODE NETWORK

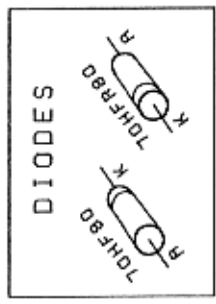
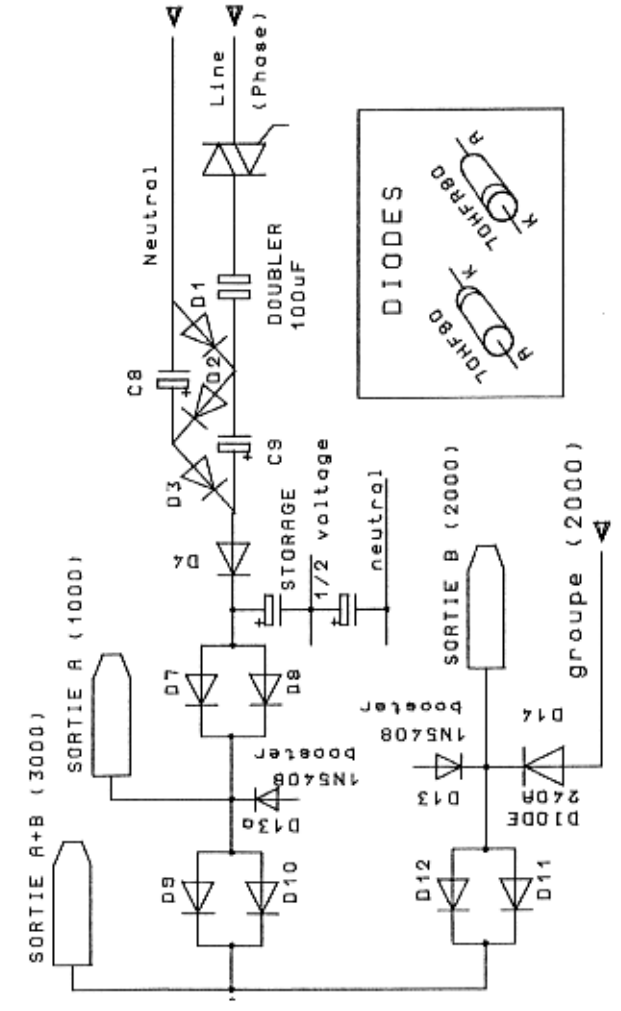
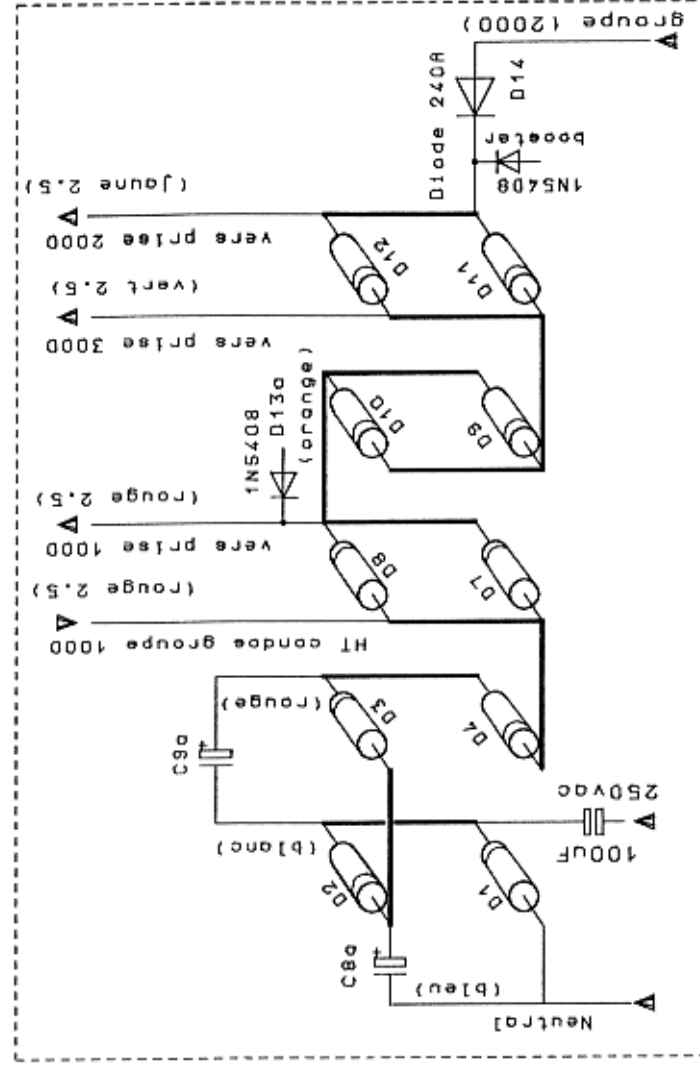

COMBI 3000 (230V)
 Groupe 2000Ws

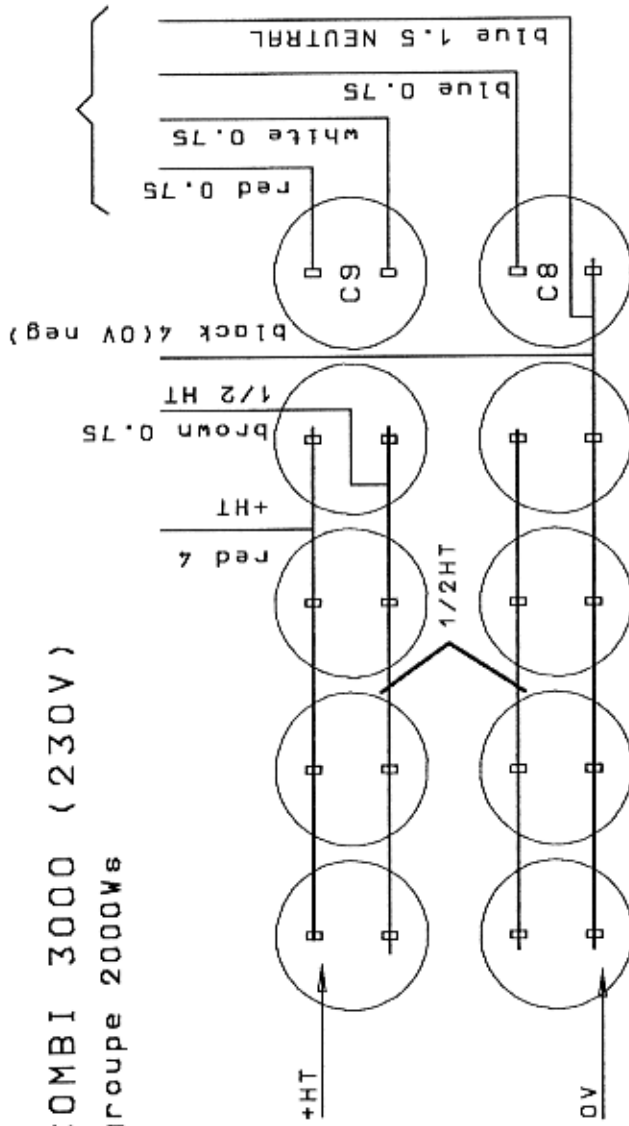

Groupe 1000Ws

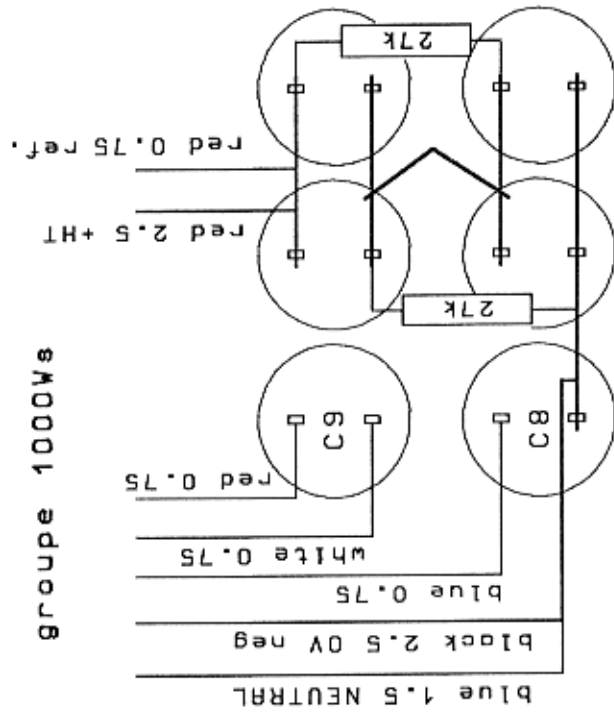

BOARDS

PB1 = Charge control

PB2 = Charge speed + triac control 2000

PB3 = Trigger + overvoltage protection

PB4 = Equilibration control (2000 only)

PB5 = Master board

FACE COMPONENTS 230V VERSION

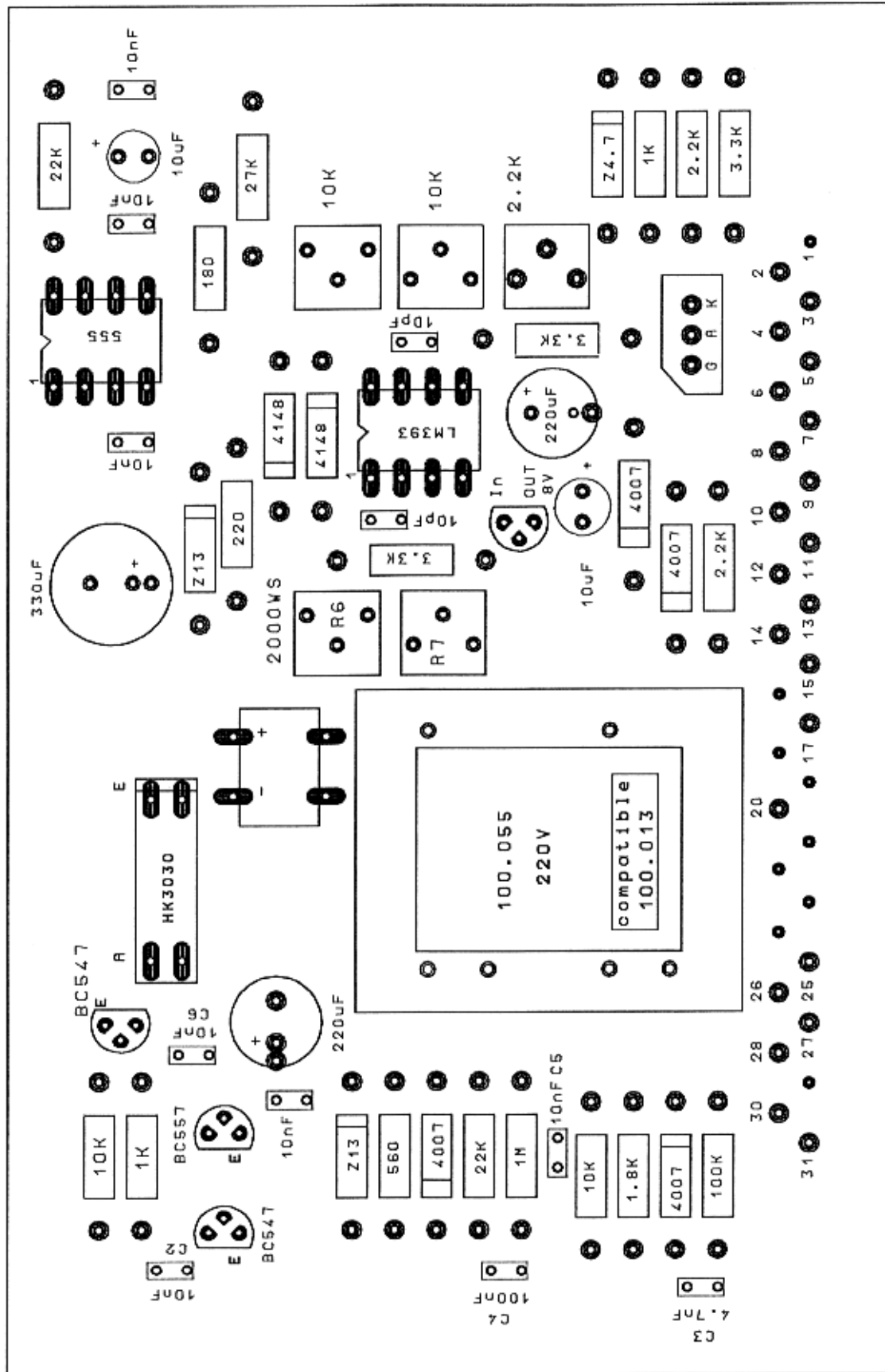

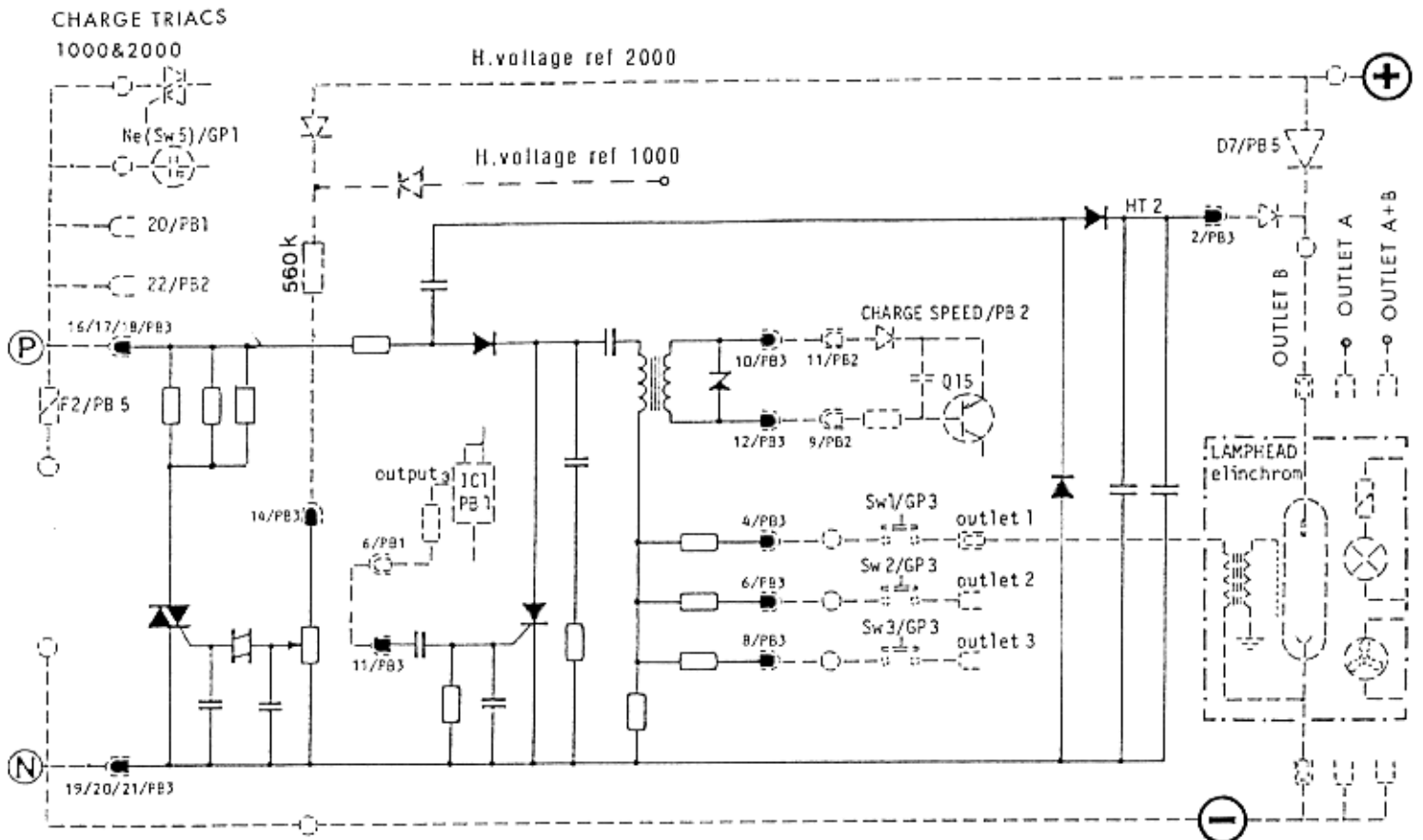

DIAGRAM CONNECTION PB3
FOR COMBI 3000 (2000 group)

UNLESS OTHERWISE SPECIFIED

- all resistors 1/2 W, 5 %
- all diodes 1 N 4007

OVERVOLTAGE PROTECTION

TRIGGER

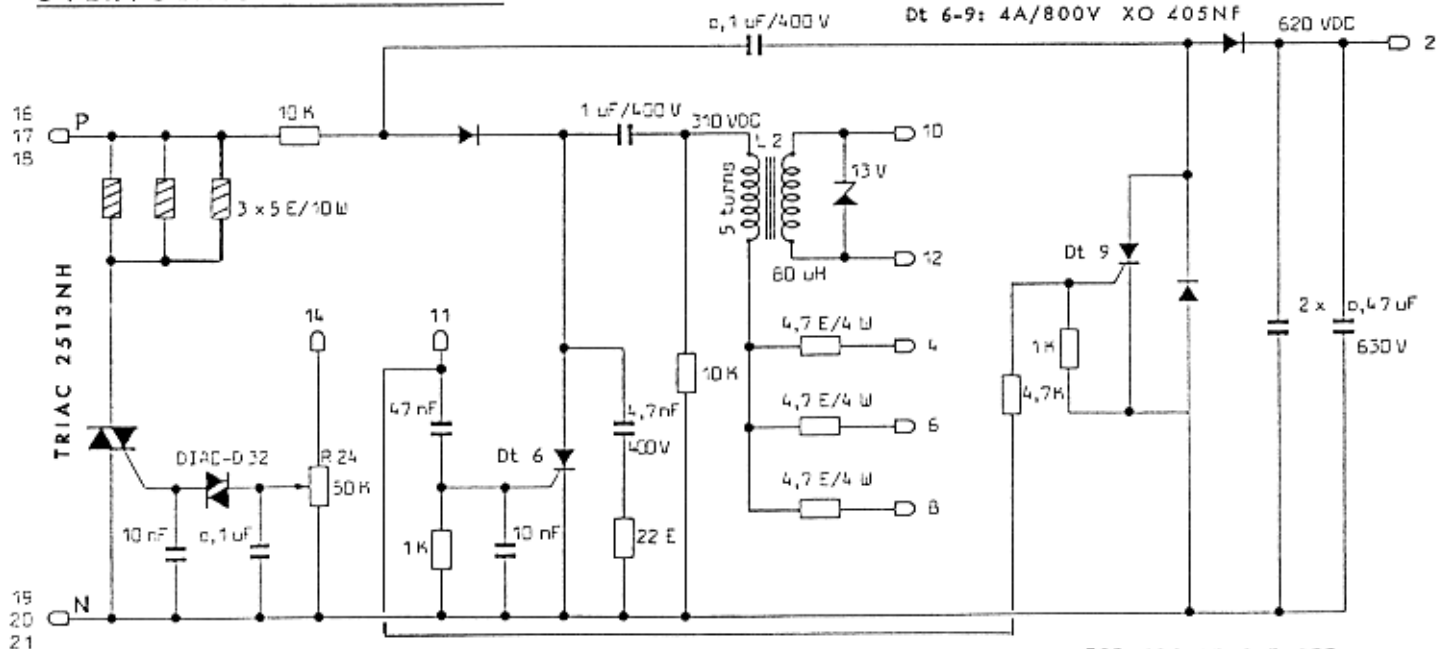

FOR ADJUSTMENT SEE:
Instructions for adjusting
Over-Voltage Protection

PB3 230V/50/60Hz
14606 BOARD ASSEMBLY

INSTRUCTIONS FOR ADJUSTING OVER-VOLTAGE PROTECTION (PB3)
 Réglage de la protection aux surtensions de charge
 Anleitung zum Justieren des Ueberspannungsschutzes

230V/50/60Hz

1- CONNECT "INPUT CURRENT LIMITER"

Brancher le "limitateur de courant d'entrée"
 "Vorrichtung zur Netzstrom-Begrenzung" anschliessen



2- ATTACH R parall. to R* interface

Ajouter R en parall. sur R*
 R parall. über R* einsetzen :

$R = 4,7 \text{ M}\Omega$

OVERVOLTAGE 1000/2000

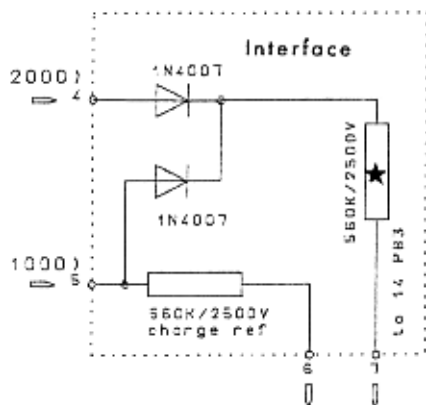

$$680 \text{ VDC} \frac{\text{lim.}}{r(R)} = (745 \text{ V})$$

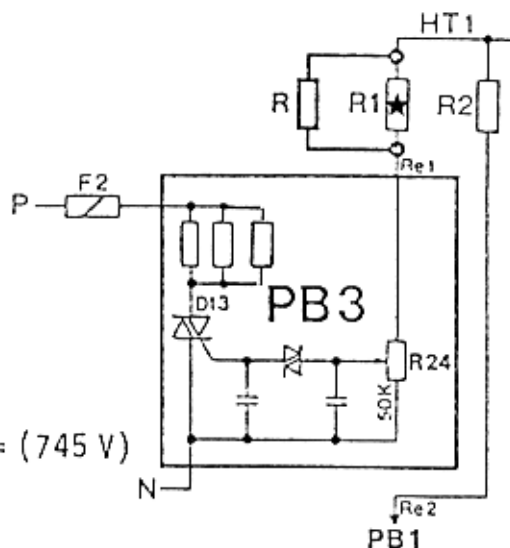

THIS PRODUCES A REFERENCE EQUIVALENT TO A HIGHER VOLTAGE THAN THAT OF THE ACTUAL HT1.

Cela produit une référence équivalente à une tension de charge supérieure à celle existante aux bornes des condensateurs, HT1.

Dies wirkt wie eine Ueberspannung, während jedoch die Kondensatoren normal aufgeladen sind.

3- TURN TO MAXIMUM R24/PB3

Tourner au maximum R24/PB3
 R 24/PB3 zum Maximum drehen

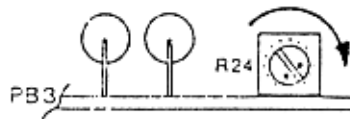

4- Select

CHARGE TO : P1/1
 charger à :
 aufladen :

: 680 VDC

5- ADJUST R24/PB3 TO POSITION AT WHICH THE LAMP LIGHTS UP FULLY

Tourner R24/PB3 jusqu'au seuil où la lampe s'illumine fortement
 R24/PB3 justieren, bis die Lampe voll aufleuchtet

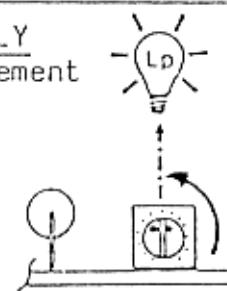

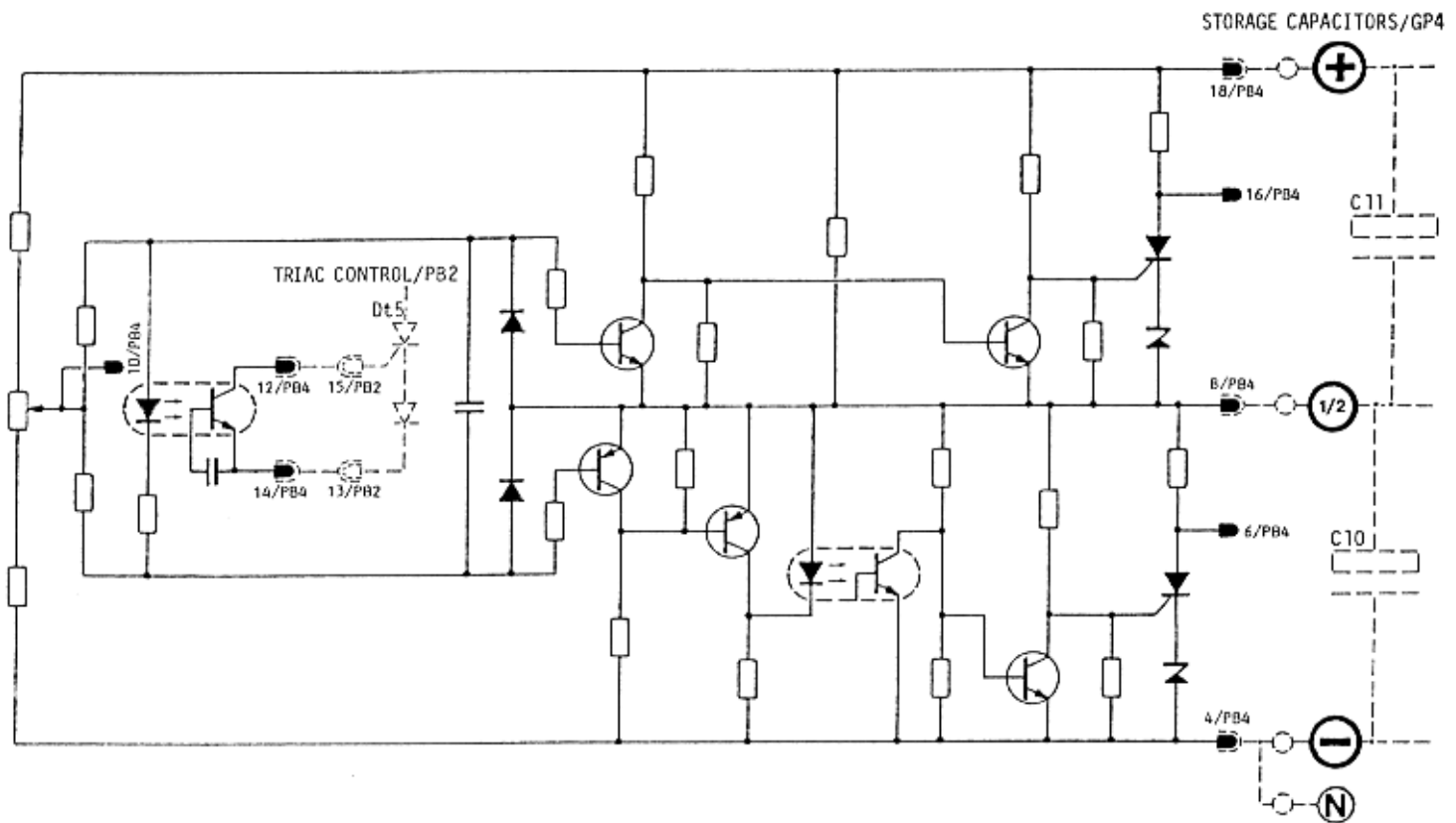

**DIAGRAM CONNECTION PB4
FOR CLASSIC (ALL models) and COMBI 3000**

- UNLESS OTHERWISE SPECIFIED
- all resistors 1/2 W, 5 %
 - Q 8-9-12: BC 547 B (BC 184)*
 - Q 10-11: BC 557 B (BC 214)*
 - OC 3 : PC 713
 - Dt 7 - 8: SO802 MH (105.032)

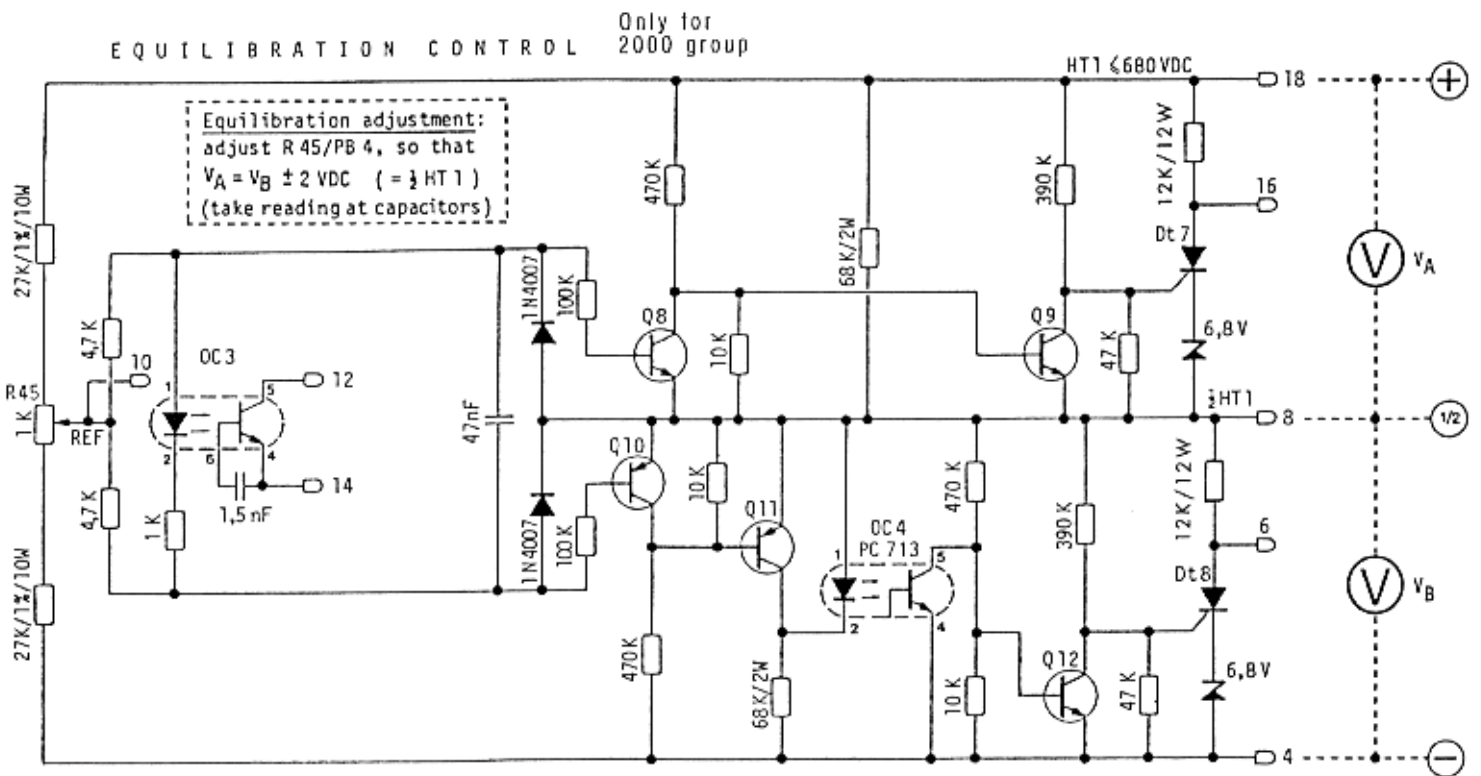

**PB4 115V/230V
14608 BOARD ASSEMBLY**

This circuit is adjusted in the course of manufacture to a high stability level ($\pm 1\%$)

Replacing the PB4

Full adjustment of the PB4 requires elaborate test equipment which is uneconomical to acquire for a repair department and is not therefore described here.

The equilibration (balance) adjustment is easy to check

The "normal" deviation between the voltages of capacitors groups C10 and C11 is between 0 and 8 volts. If this deviation is higher (9-15 volts) readjust the trimmer R45/PB4 :

- connect two voltmeters, one between the points \ominus and $\textcircled{1/2}$ (voltage of C10) and the other between points $\textcircled{1/2}$ and \oplus (voltage of C11).
- gradually turn R45/PB4 in the one or other direction until the voltage difference is within the "normal" range.

(A voltage unbalance greater than 16V indicates a defect)

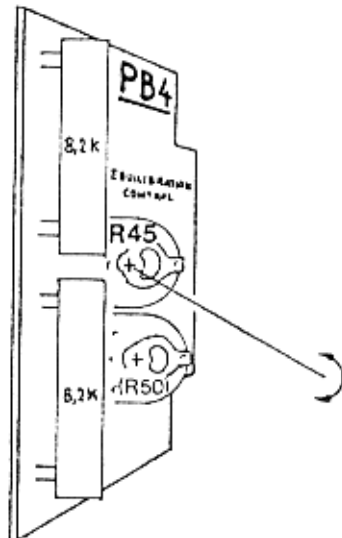

Do not readjust the trimmer R50/PB4. If this has been accidentally moved reset it to its mid-position. Its effect on charge control would only be slightly modified.

Diese Schaltung wird bei der Herstellung auf einem hohen Stabilitätsgrad justiert ($\pm 1\%$).

Ersatz der Platte PB4

Für eine volle Justierung der Platte PB4 sind aufwendig Prüfgeräte erforderlich, die für eine Reparaturwerkstatt nicht wirtschaftlich sind und daher nicht hier beschrieben sind.

Die Justierung des Ladeausgleichs ist einfach zu prüfen :

Die normale Spannungsabweichung zwischen den Kondensatorgruppen C10 und C11 beträgt 0-8 V. Ist diese Abweichung höher (9-15 V), wird der Trimmer R45/PB4 wie folgt justiert :

- zwei Voltmeter anschliessen : einen an die Punkte \ominus und $\textcircled{1/2}$ (Spannung von C10) und den anderen an die Messpunkte $\textcircled{1/2}$ und \oplus (Spannung C11).
- Trimmer R45/PB4 langsam in der einen oder anderen Richtung drehen, bis die Spannungsabweichung im zulässigen Bereich liegt.

(Eine Spannungsabweichung von mehr als 16 V ist auf eine Funktionsstörung zurückzuführen).

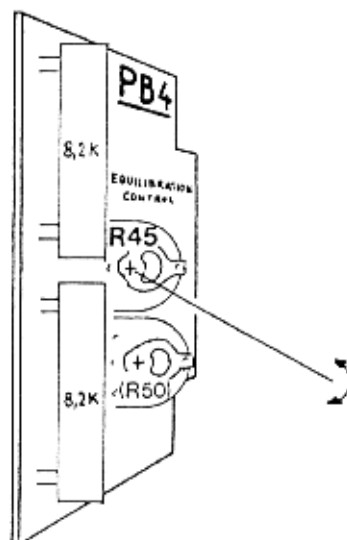

Der Trimmer R50/PB4 darf nicht nachjustiert werden. Sollte dieser versehentlich verstellt sein, wird er in seine Mittelstellung zurückgedreht. Sein Einfluss auf die Ladesteuerung ist dann nur gering modifiziert.

Remplacement PB4

Ajusté à la fabrication, ce circuit a une bonne stabilité ($\pm 1\%$).

L'ajustage complet de PB4 nécessite un appareillage de contrôle élaboré qu'il serait irrationnel de décrire et de proposer aux départements de service.

L'ajustage de l'équilibrage est facile à contrôler

L'écart "normal" entre les tensions des groupes de condensateurs C10 et C11 se situe entre 0 et 8V. Si cet écart devait être plus élevé (9 à 15V), réajuster le trimmer R45/PB4 :

- brancher si possible deux voltmètres, l'un entre les points \ominus et $\textcircled{1/2}$ (tension C10) l'autre entre les points $\textcircled{1/2}$ et \oplus (tension C11).
- tourner progressivement R45/PB4 dans un sens ou l'autre jusqu'au rétablissement d'un écart de tension "normal".

(Un déséquilibre des tensions supérieur à 16V est dû à une défectuosité)

Le trimmer R50/PB4 ne doit pas être dérégulé. Dans le cas d'un déplacement accidentel, le replacer en position demi-ouverture. La réaction au blocage de la charge n'en serait que peu modifiée.

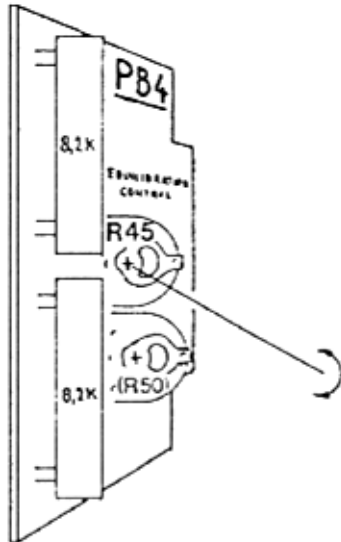

PB5 COMBI 3000

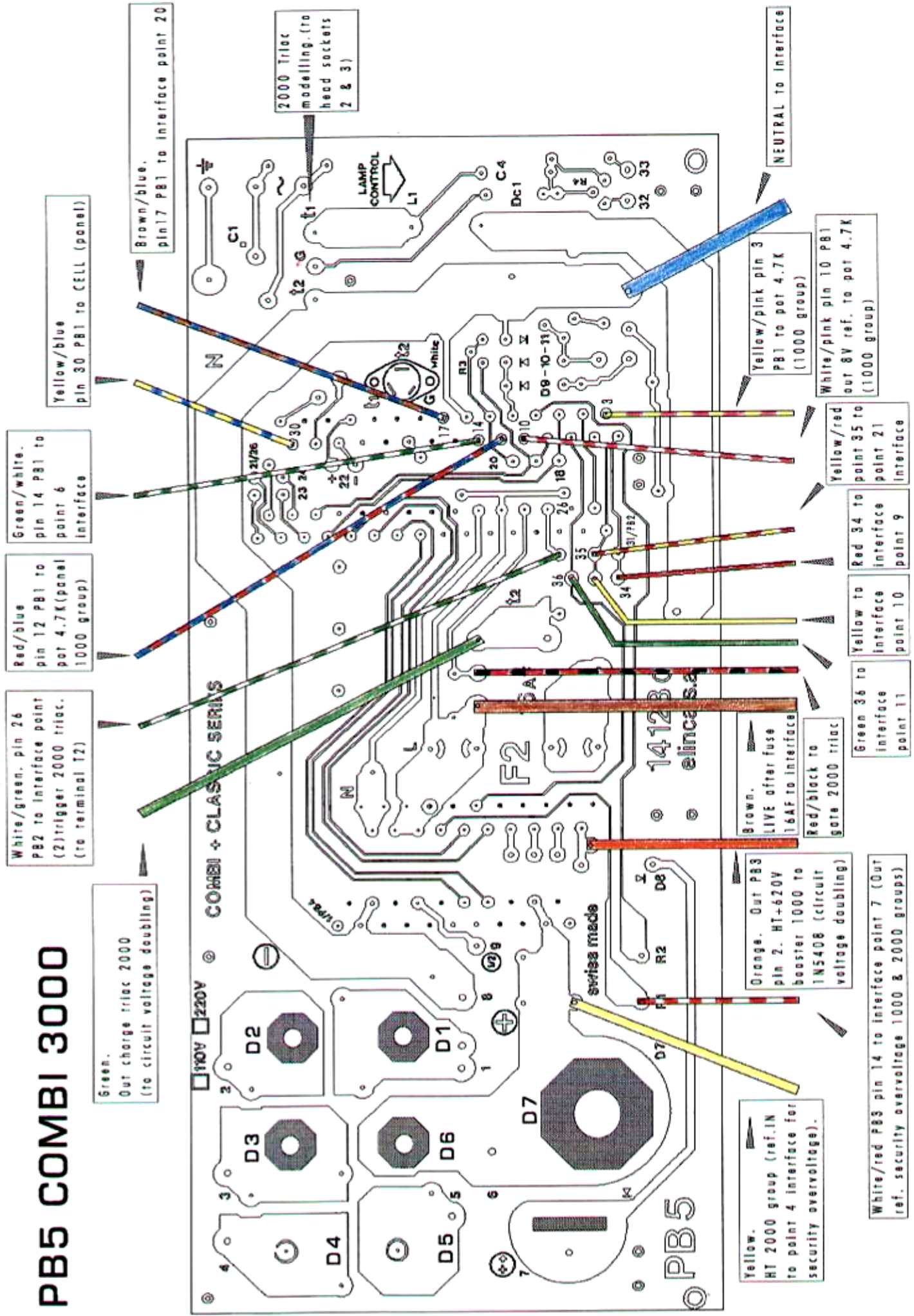

INTERFACE

- Control modelling (Pilote) 1000
- Control triggering triac 1000
- Acoustic signal
- Ref. control voltage 1000
- Ref. overvoltage "security" 1000 & 2000

TRIAC DRIVER 1000

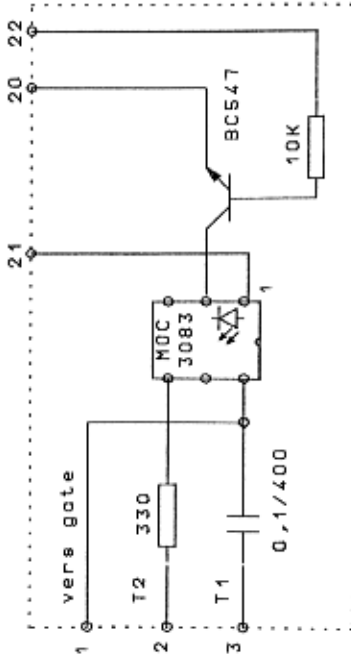

SWITCH PANEL

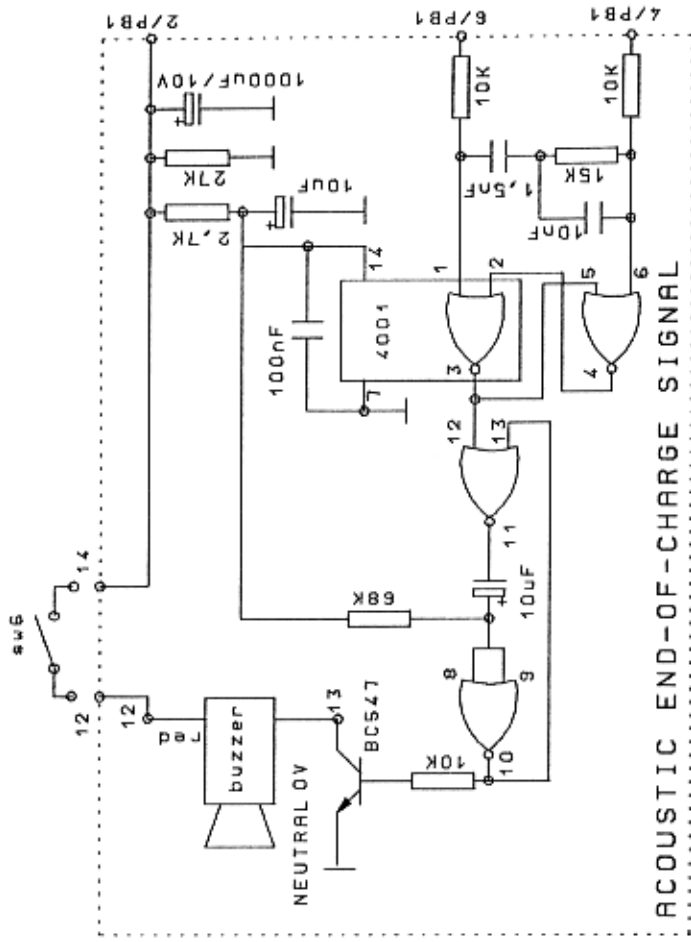
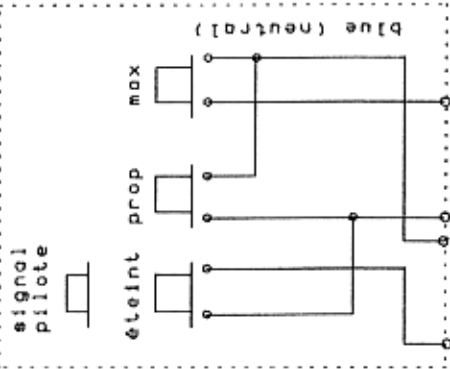

ACOUSTIC END-OF-CHARGE SIGNAL

OVERVOLTAGE 1000/2000

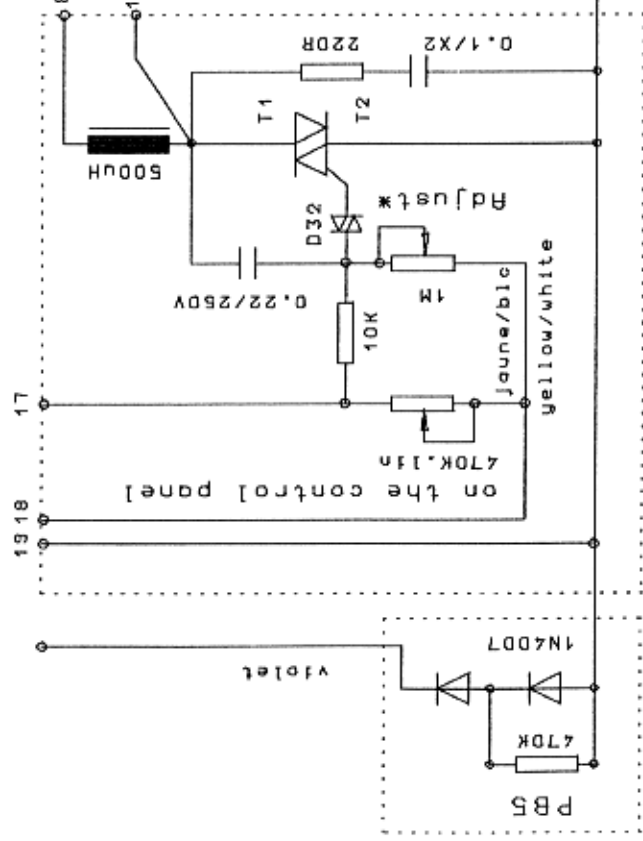
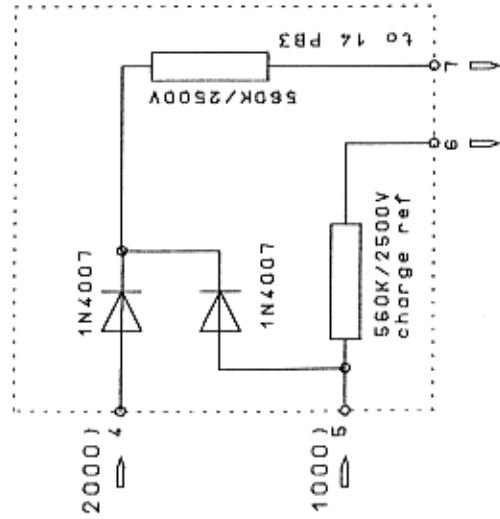

MODELLING 1000

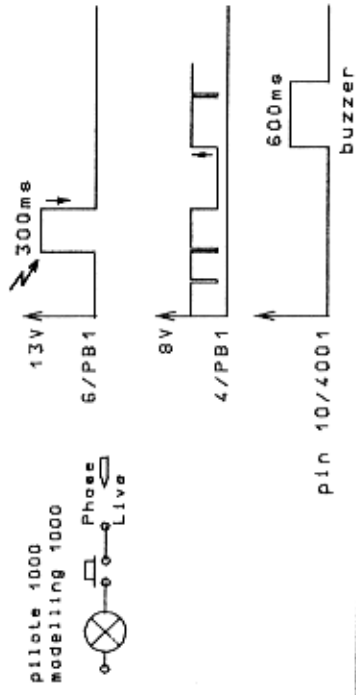

Adjustment* 70V_{ac}
at line 230V/50Hz

Adjustment* 53V_{ac}
at line 230V/60Hz

Test R+J +8V
bleu 0V
vert 0/1/0 (deligt)

SCHEMA INTERFACE COMBI Print assembly 14617

230V/50/60HZ VERSION

CHARGING SPEED SELECTOR
 SELECTEUR DE CHARGE

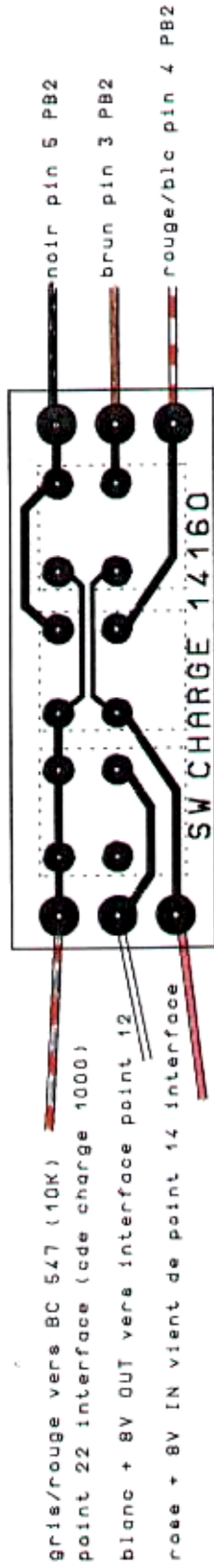

MODELLING LAMP AND PILOT SIGNAL SELECTOR

SELECTEUR LAMPE PILOTE

Sig/pilote Prop Max

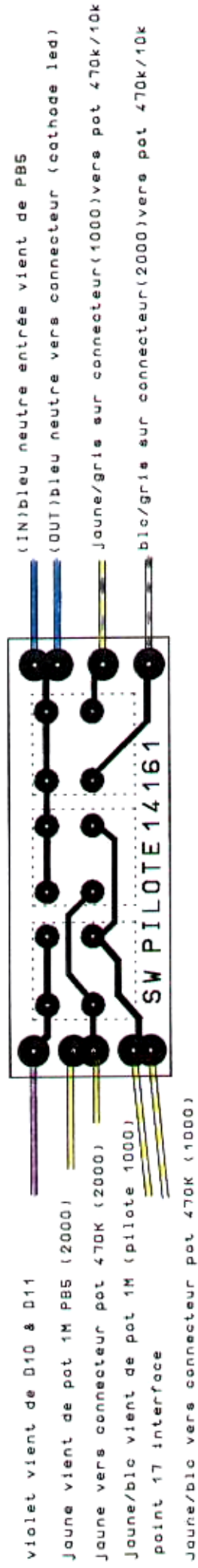

Pushbutton Switch 14643
 Black Cap 204.108

MISCELLANEOUS DIVERS

- Panel wiring
- Regulator – linear potentiometers
- Power supply for fan
- Voltage doubling capacitors
- Auxiliary socket interface

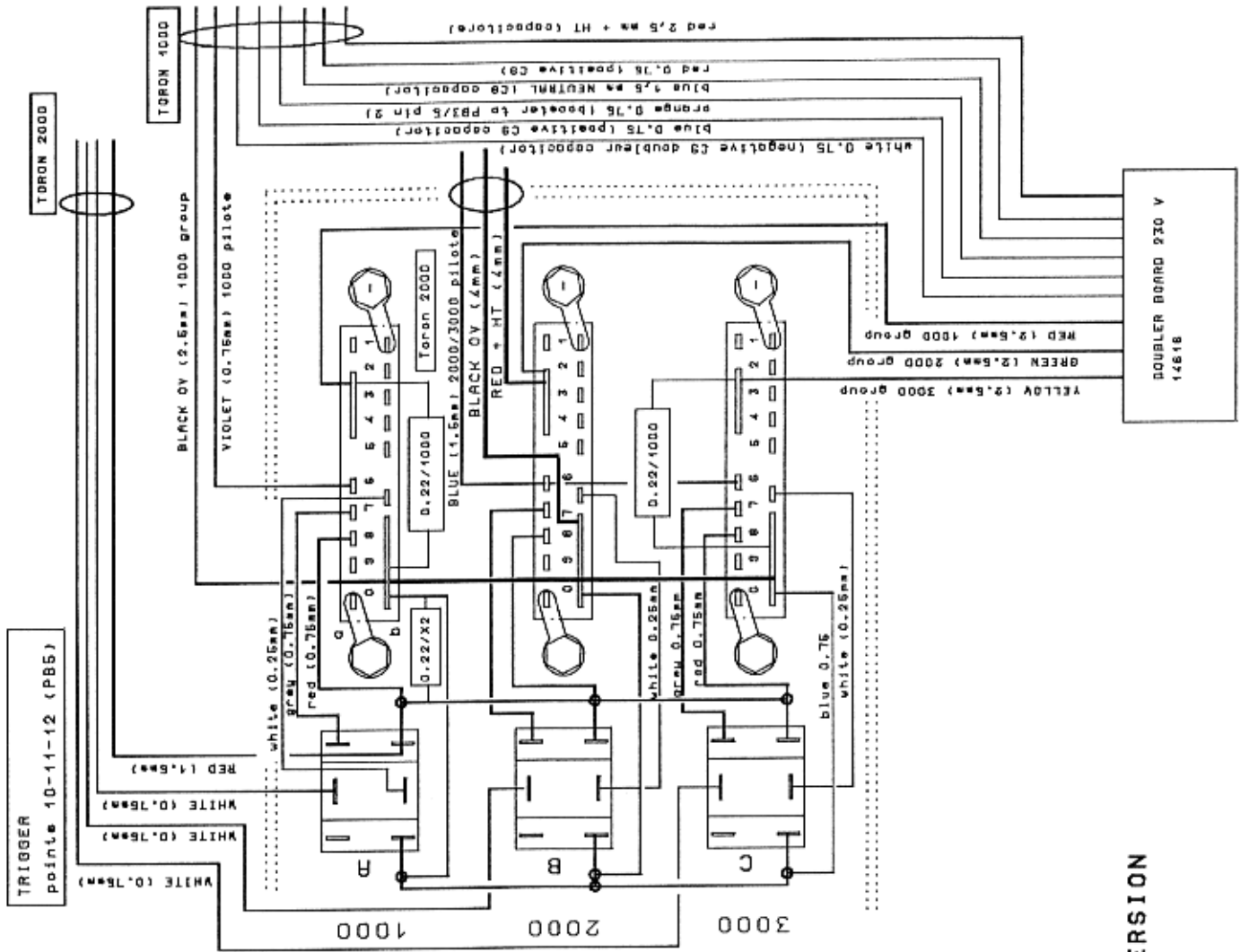



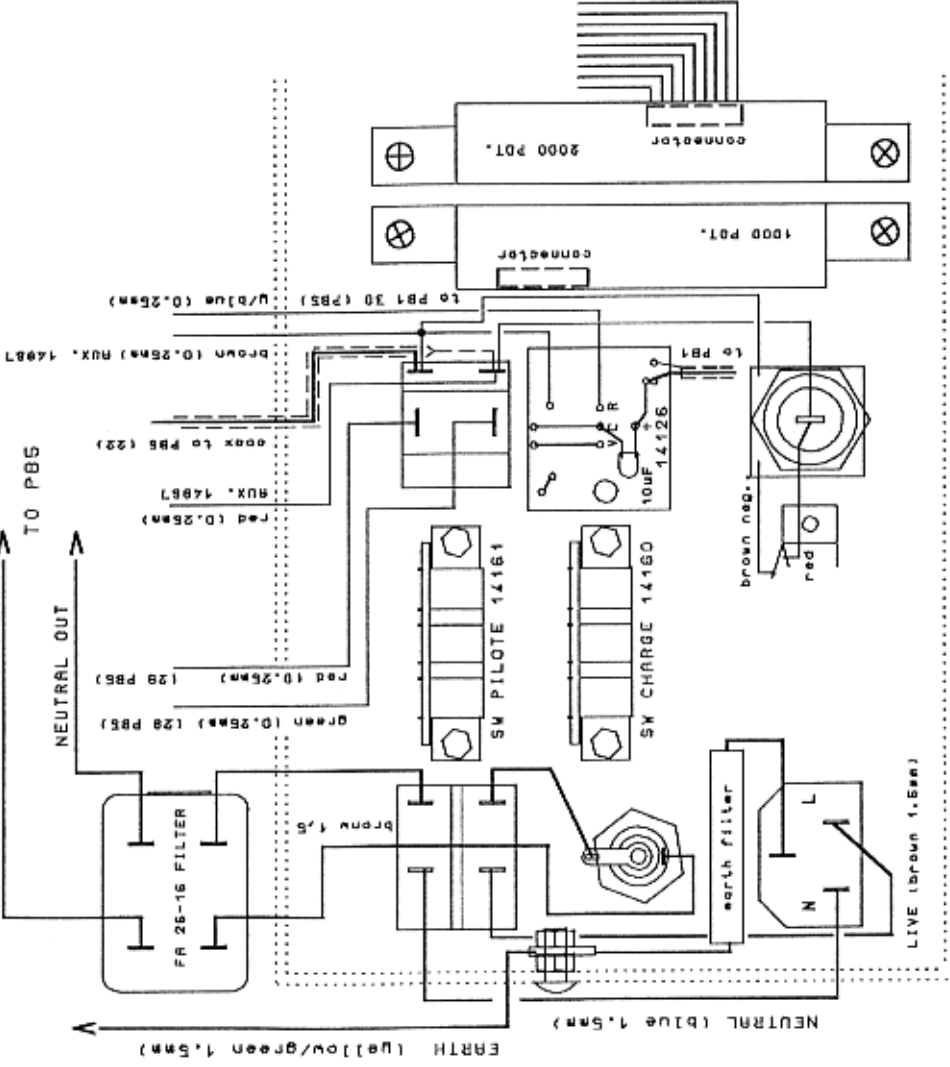



TRIGGER
points 10-11-12 (PB5)









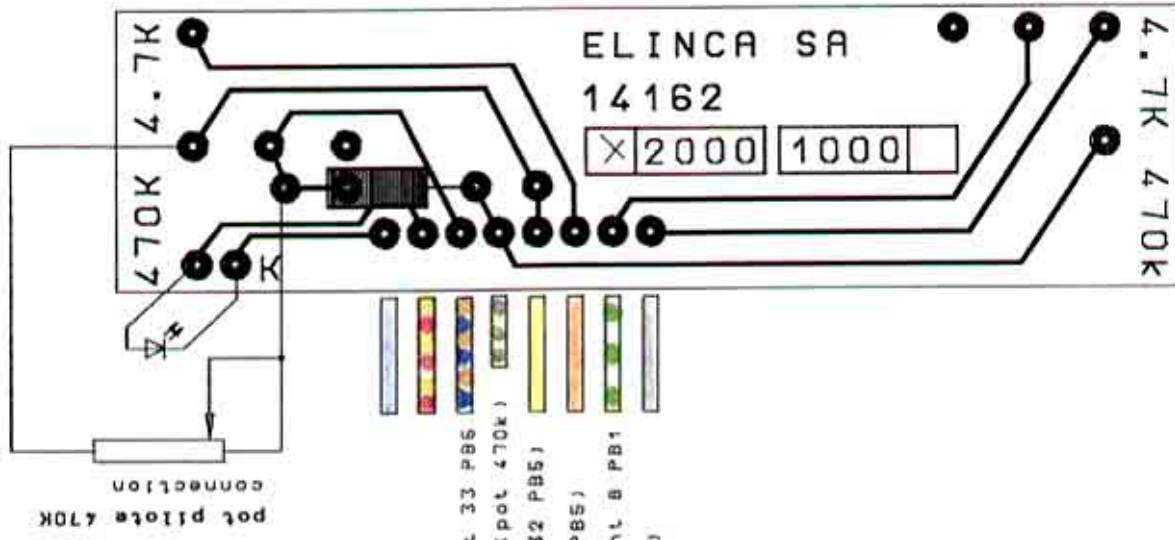

PANNEAU COMBI 230V VERSION

print 14162
 pot tandem 109.027
 pont 120.001
 led rouge 5mm

-  réf +8V point 10 PB1 rose/blanc
-  vers point 3 PB1 curseur (jaune/rose)
-  vers point 12 PB1 (rouge/bleu)
-  vers 10k (pilote interface) jaune/gris
-  vers curseur (pilote interface) jaune/blanc
-  vers pot 1M (interface) blanc/bleu



-  bleu vers switch pilote NEUTRE
-  j/rouge vers point 1 PB2
-  bl/brun vers pot 1M (R10k) point 33 PB5
-  bic/gris vers sélecteur pilote (pot 470k)
-  J vers sélecteur pilote (point 32 PB5)
-  orange réf +8V point 7 PB1 (18 PB5)
-  bic/vert point 19 PB5 (max) point 8 PB1
-  gris point 20 PB5 (point 13 PB1)

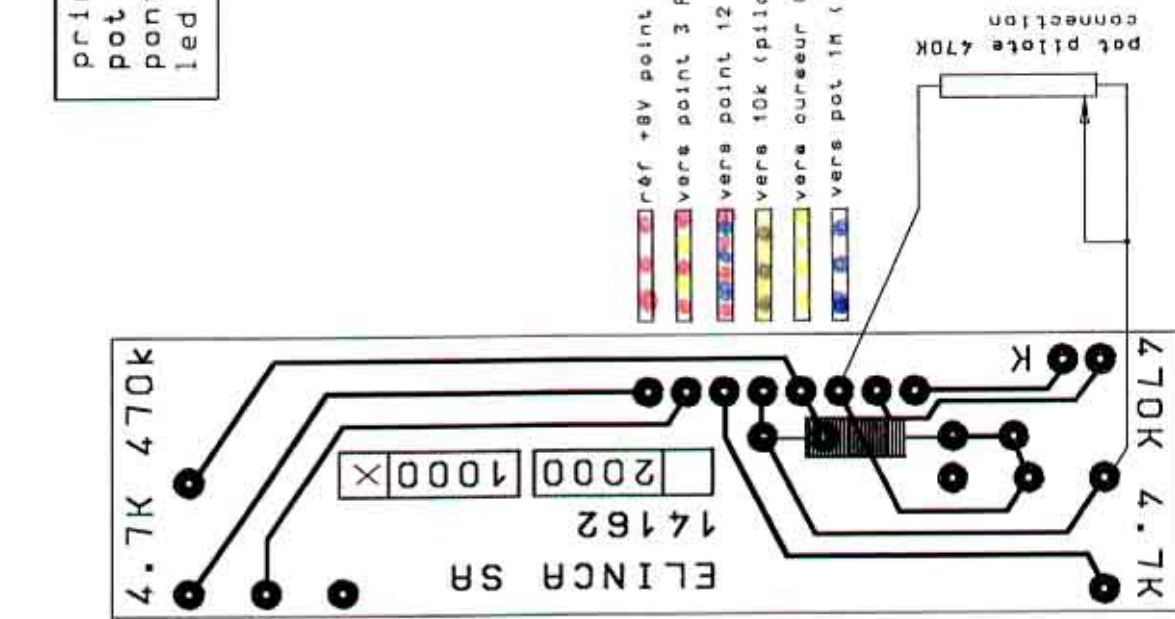

VERSION 120V

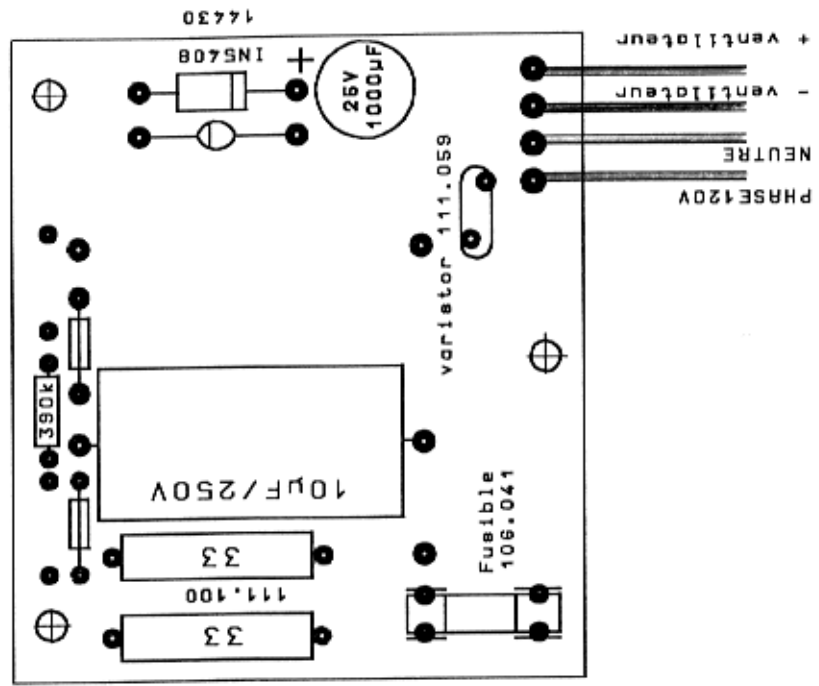

VERSION 230V

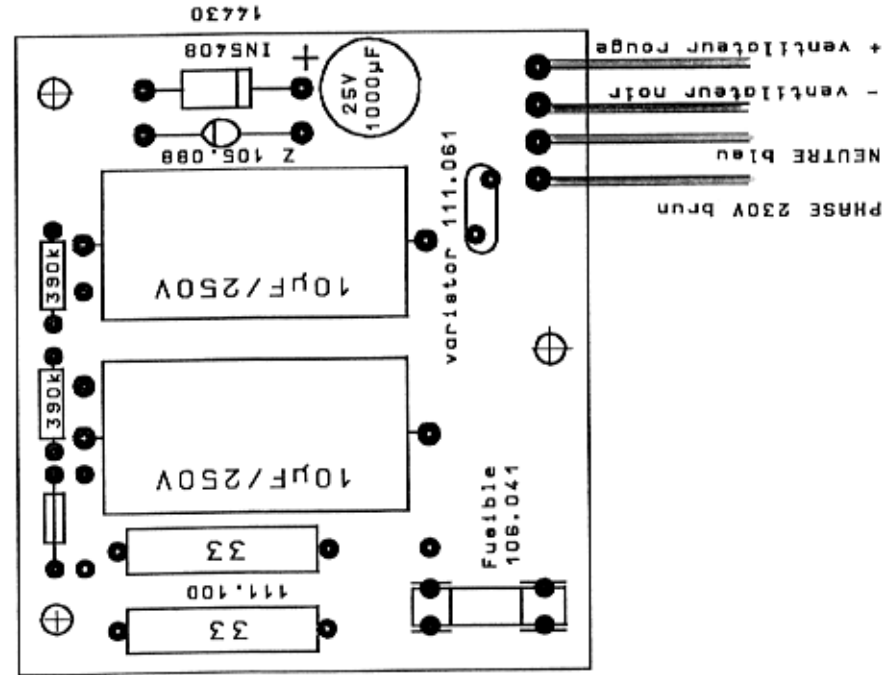

POWER SUPPLY – NETZTEIL

Alimentation 230 V ventilateur COMBI

14618	1	Alimentation montée (circuit assembly)
14159	1	print nu (board only)
104.113	2	condos MKT1813-610/255 (10uF,250V Roderstein)
106.039	2	clips pour fusible
106.041	1	fusible 800 mAT
104.084	1	condo radial 1000uF/25V
14430	1	diode 1N5408
121394	2	résistances 390K
105.088	1	diode zener 20V
111.100	2	résistances 33R/7W
111.061	1	varistor 250V
120.001	1	pont (jumper)

Alimentation 120 V ventilateur COMBI

14619	1	Alimentation montée (circuit assembly)
14159	1	print nu (board only)
104.113	1	condos MKT1813-610/255 (10uF,250V Roderstein)
106.039	2	clips pour fusible 5x20
106.041	1	fusible 800 mAT
104.084	1	condo radial 1000uF/25V
14430	1	diode 1N5408
121394	1	résistances 390K
105.088	1	diode zener 20V
111.100	2	résistances 33R/7W
111.059	1	varistor 110V
120.001	2	ponts (jumper)

209.099	3	entretoises à déclic (sur équerre) (spacer)
---------	---	---

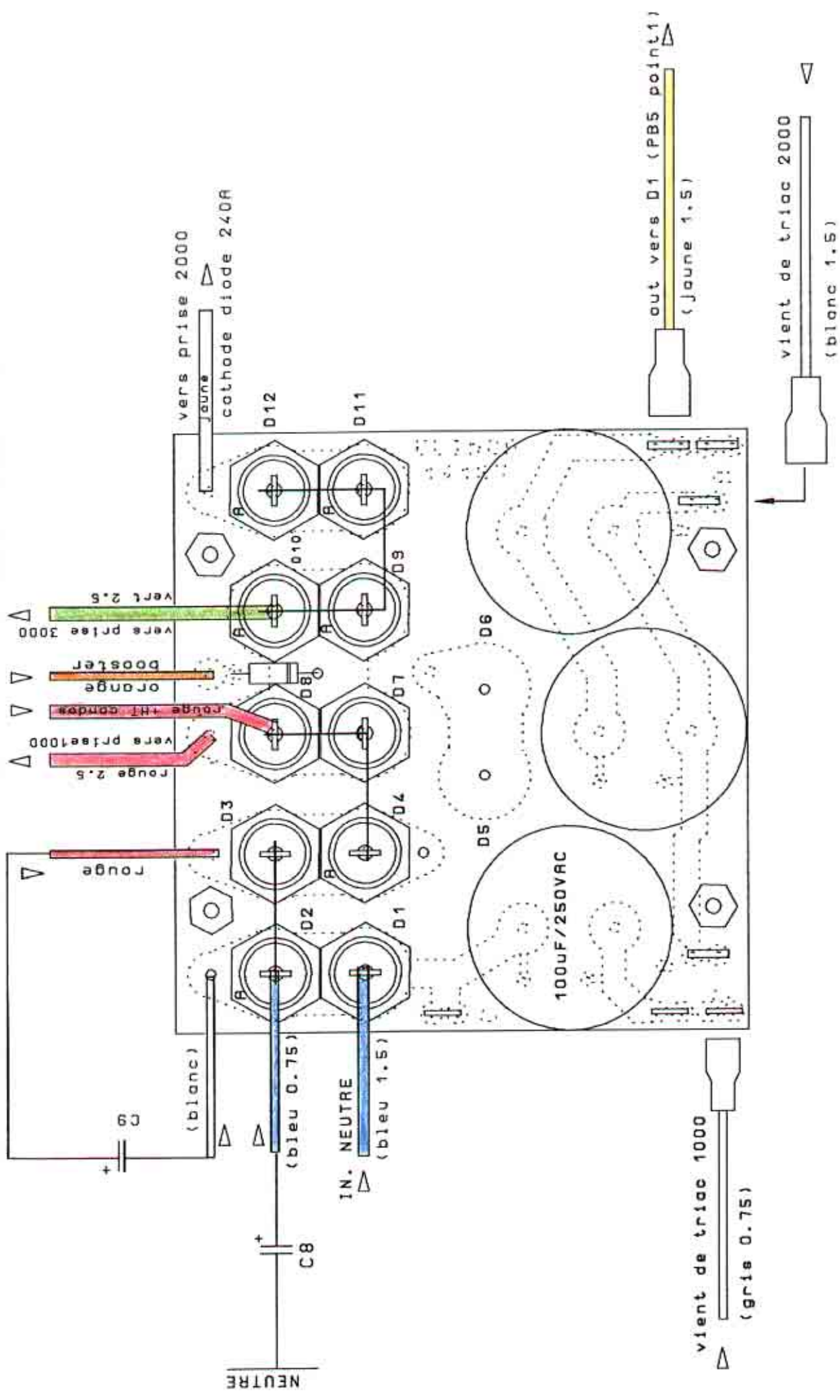

Montage circuit doubleur COMBI 230V (14622)

VOLTAGE DOUBLING CAPACITORS

DOUBLEUR 230V COMBI 3000

14622	1	circuit monté (circuit assembly)
14157	1	circuit nu (board only)
105.080	6	diodes 70HFR (Anode au boîtier)
105.087	4	diodes 70HF (Cathode au boîtier)
210.117	10	rondelles M6
209.120	4	entretoises hexa.. PA M4x20
112.078	2	languettes 6.3
112.075	1	languettes 4.8
104.111	3	condos 100uF/250VAC
211.879	6	vis M5x10
203.032	4	écrous M4
14430	1	diode booster 1N5408
121.564	2	résistances 560 K
204.211	1	isolant doubleur PVC 0.5 (insulator)

AUXILIARY SOCKET INTERFACE

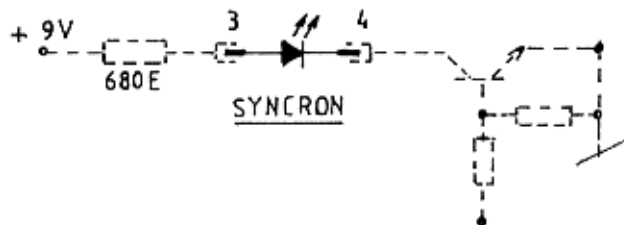
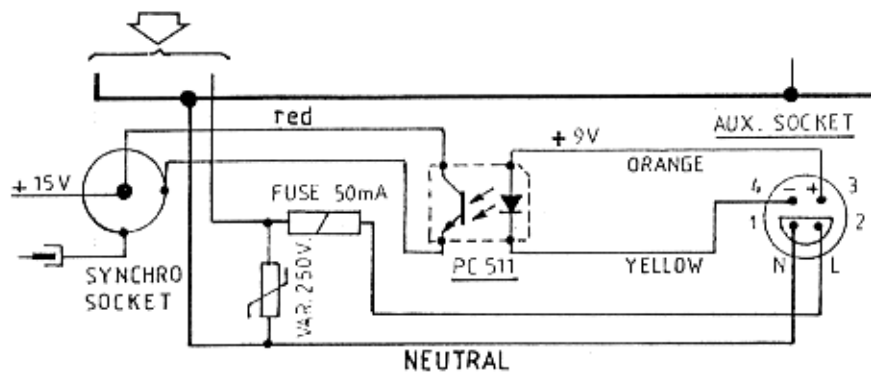
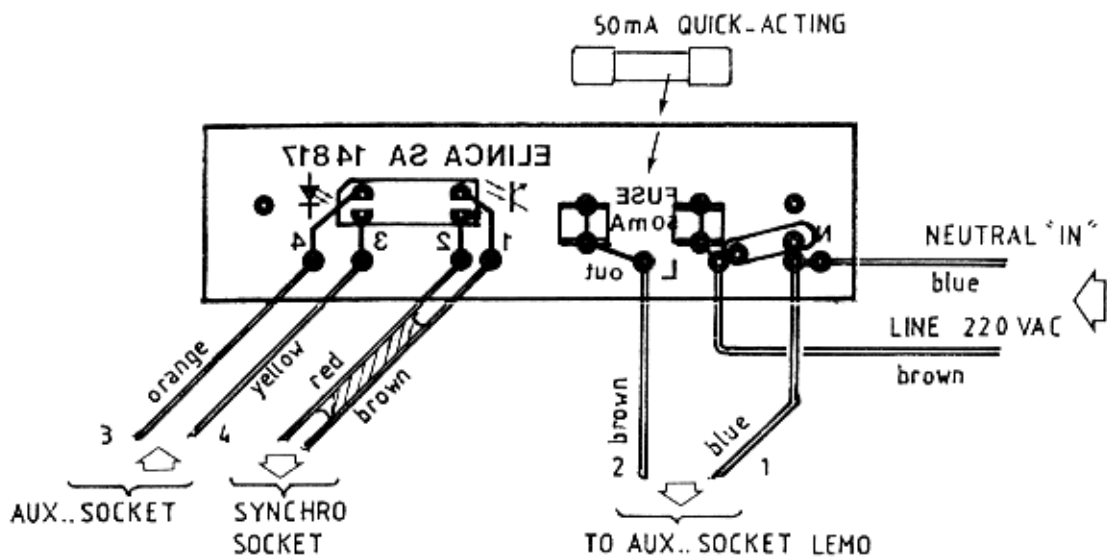

PART N° SPECIFICATION

14817	PRINT
111.061	VARISTOR 390k 250 VAC
106.039	SPRING FUSE HOLDER
106.040	FUSE 5x20mm 50mA
105.053	PHOTOCOUPLER PC 511 or HK 3030
	Long Creeping Distance

CIRCUIT ASSEMBLY 14867

CHARGE TRIACS

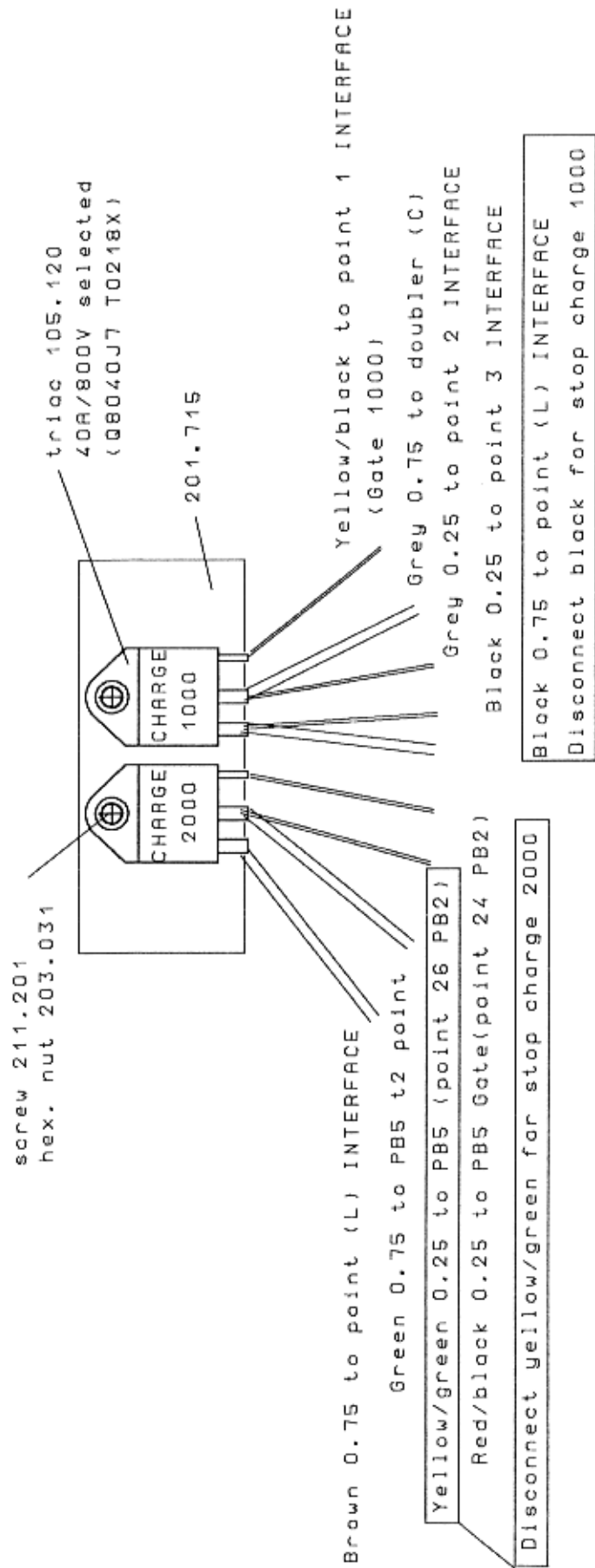

LIST OF COMPONENTS

PARTS LIST FOR COMBI 3000

1B

DESCRIPTION 230V/60Hz VERSION	USED ON	ORDER	STOCK SERVICE
ASSEMBLY BOARDS:			
PB1 230V/50Hz	Combi + Classics	14615	
PB2 *	Combi + Classics	14600	
PB3 *	Combi + Classics	14606	
PB4 115/230V	Combi + Classics	14608	
PB5	Combi + Classics	610.023	
PB5 with stranded conductors		640.313	
Interface board *charge + modelling 1000 group*		14622	
Commutable photocell circuit (with element)		14644	
Auxiliary board interface (for socket 4p.)		14867	
Fan power supply 20Vdc		14618	
Voltage doubling capacitors		14622	
SWITCHES:			
Momentary switch *OPEN FLASH* (green)	Combi 1 Classics	14309	
Latching switch *MODELLING* (yellow)	Combi + Classics	14647	
Principal rocking switch (red)	Combi + Classics + Micro	14645	
Commutable switch 3 pos. (selectors)	Combi + Classics	14643	
Black cap for 14643	Combi + Classics	204.108	
CAPACITORS:			
Charge capacitor 3300uF/360V	Combi + Classics + Micro	14340	
Doubler cap.100uF/250Vac		104.111	
Trigger cap. 1 uF/400V	Combi + Classics	104.025	
Booster cap. 0.47/630V (PB3)	Combi + Classics	104.024	
Doubler cap. for booster 0.1/400V (PB3)		104.104	
10pF/100V	(All mod)	104.001	
4.7nF/100V	(All mod)	104.105	
4.7nF/500V	Combi + Classics	104.006	
10nF/50V	All mod)	104.007	
47nF/250V	(Pb3)	104.012	
100nF/50V	(All mod)	104.015	
100nF/250V		104.016	
1uF/400V [supply PB2]		104.025	
10uF/16V tantal	All mod)	104.029	
RESISTORS:			
4.7 E/4W trigger (PB3)	Combi + Classics	110.050	
5 E/10W Security overvolt. (PB3)	Combi + Classics	111.051	
18 E/1W (Pb2)	Combi + Classics	121.180	
39 E/1W (Pb2)	Combi 1 Classics	111.038	
100 E/2W (Pb2)	Combi + Classics	111.039	
12K/12W (Pb4)	Combi + Classics	111.055	
27K/10W (Pb4)	Combi + Classics	111.052	
560K/2W 2500V (Interface)		121.564	

PARTS LIST FOR COMBI 3000

2

DESCRIPTION 230V/50/60Hz VERSION	USED ON	ORDER	STOCK SERVICE
POTENTIOMETERS:			
Linear pot. tandem 4.7K + 470K		109.027	
Button colored green for pot. 109.027		103.064	
Trimmer Cermet 2K (PB1 linearity 1000)		109.023	
Trimmer Cermet 2K (PB5 – R4 adj modelling 2000)	(All mod)	109.023	
Trimmer 10K (PB1)	(All mod)	109.001	
Trimmer 1M (Interface modelling 1000)		109.024	
Trimmer 1M (PB5 – R3 adj linearity 2000)	(Combi + Classics)	109.015	
DIODES:			
1N4148 75V/300mA	(All mod)	105.051	
1N4007 1000V/1A	(All mod)	14009	
1N5408 1000V/3A	(All mod)	14430	
Bridge Dual DIP 1A/400V	(All mod)	105.057	
Power diodes D1–D2–D3–D6. 800V/70A (70HF80 case Anode)	(Combi + Classics)	105.087	
Power diodes 800V/70A for doubler board (70HFR80 case Cathode)		105.080	
Power diode D7. SKN 240/08. 800V/240A	(Combi + Classics)	201.714	
Zener diode 13V 1/2W (All mod)		105.006	
SEMICONDUCTORS:			
Diac 32V (case DO-35)		14015	
Thyristor (SCR) 4A/800V X0405NF1AA2	(All mod)	105.116	
Thyristor (SCR) 8A/800V SO802MH	(Combi + Classics)	105.032	
Triac 25A/800V T2513NH Security	(All mod)	105.049	
Triac 40A/800V Teccor Q8040J7 (charge triacs)		105.120	
Triac 25A/700V BTA-25/700 for modellings	(Combi + Classics)	14635	
Transistor BC 547 NPN 45V/100mA	(All mod)	14012	
Transistor BC 557 PNP 45V/200mA	(All mod)	14013	
INTEGRATED CIRCUITS:			
LM 393 dual voltage comparator		105.055	
Timer NE 555 (Pb 1 + Pb2)	(All mod)		
Reference voltage 8V LM78L08A	(All mod)	105.040	
OPTO-ELECTRONICS:			
Solid state relay triggering (interface) MOC 3083		105.039	
Photocoupler PC 713 or KP 2010 (PB1–2–3)	(All mod)	105.053	
Photocoupler synchro (PC 511 old) HK 3030	(All mod)	105.053	
Phototransistor PT 361 (high sensivity)	(All mod)	105.028	
LED red 5mm (panel signal formation)		108.023	
LED green/red rectangular (board cell)	(Combi + Classics)	108.008	

PARTS LIST FOR COMBI 3000

3

DESCRIPTION 230V/50/60Hz VERSION	USED ON	ORDER	STOCK SERVICE
DIVERS:			
Transformer 230V/2x15V (PB1)	(or 100.013 compatible)	100.055	
Line filter FA26-16	(Combi + Classics + Micro)	104.112	
Complete condensators bank		640.310	
Capacitor holder	(All mod)	206.052	
Charge selector 3 pos. complete		640.300	
Modelling selector 3 pos. complete		640.301	
Fan 24 Vdc		107.015	
Buzzer (acoustic signal)		107.019	
linear pot. complete with board for 1000 group		640.306	
linear pot. complete with board for 2000 group		640.305	
Self 550uH/3A (Triac filter, interface board)		100.044	
FUSES + HOLDER:			
Fuse holder for 5x20mm	(Combi + Classics)	14651	
Principal fuse 16AT 5x20mm (time lag)	(All Combi + Classics + Micro)	19057	
Security fuse 16AF (flink) 6x35mm internal (PB5)	(All packs)	19024	
Fuse 800mAT 5x20mm for supply fan (time lag)		106.041	
Fuse 50mAF (flink) for auxilliary board		106.040	
CONNECTORS:			
Lamphead outlet 20 p. female	(Combi + Classics)	22047	
Shroud for 22047 *socket guide with hook* (embase)	(All mod)	110.054	
Connector for PB5 21 p. female	(Combi + Classics)	14652	
Connector for PB5 31 p. female	(Combi + Classics)	14653	
Mains socket connector	(All mod)	110.083	
Auxilliary connector 4pF	(All mod)	110.086	
Synchro socket Amphenol	(Combi + Classics)	12076	
Synchro jack 3.5mm	(Combi + Classics)	110.104	
HOUSING PARTS:			
Metal housing (2 pcs) Aussenwände		301.803comp	
Complete panel with cables		640.303	
Protective bumper (Stossdämpfer)	(Combi + Classics)	204.114	