

Service Manual

Manuel de service



Schematic diagrams and part list

Schémas et liste des pièces

© Copyright Elinchrom 2004

COPYING OF THIS DOCUMENT AND GIVING IT TO OTHERS AND THE USE OF COMMUNICATION OF THIS CONTENTS THEREOF ARE FORBIDDEN WITHOUT EXPRESS AUTHORITY. CONTRAVENTION OF THIS RESTRICTION WILL RESULT IN A LIABILITY OF THE PAYMENTS OF DAMAGES. ALL RIGHTS RESERVED. THIS DOCUMENT IS THE SUBJECT OF COPYRIGHT.

Table of contents

SAFETY NOTICE	4
FRONT PANEL	5
OPERATING INSTRUCTIONS	5
MECHANICS	6
FRONT PANEL VIEW DIGITAL RX (ALL)	6
MECHANICAL PART LIST	6
MECHANICAL PART LIST	7
SERVICE MENU	8
UNIT SERVICE ADJUSTMENTS	8
ADJUSTMENTS WITH ELINCHROM REMOTE STUDIO SOFTWARE E.R.S (PC ONLY)	8
TROUBLE SEEKING GUIDE FOR DIGITAL RX	8
TROUBLE SEEKING GUIDE FOR DIGITAL RX	9
IMPORTANT NOTE	9
KNOWN PROBLEMS	9
ERROR MESSAGES	9
REPAIRING HELP	10
1. <i>Fault tracing for blown fuse</i>	10
2. <i>Repairing help for Charge Circuit</i>	10
3. <i>To trace for a faulty photo flash capacitor</i>	10
4. <i>Replacing a Photo flash capacitor</i>	10
5. <i>Modelling lamp circuitry does not function</i>	11
6. <i>Fault tracing for discharge resistor failure (E3)</i>	11
7. <i>Fault tracing for firing faults</i>	11
SPECIAL CIRCUITRY AND GRAPHS	12
<i>MOSFET charge circuitry</i>	12
<i>Flash voltage HTD (PB3)</i>	12
INTERCONNECTION DIAGRAM	13
PRINTED BOARDS	14
OVERVIEW.....	14
<i>Digital 1200 RX / 115V</i>	14
<i>Digital 2400 RX / 115V</i>	14
PB1 POWER BOARD	15
DIGITAL 1200 RX (14411)	15
<i>Schematics PB1 (14411)</i>	15
<i>Assembly drawing PB1 (14411)</i>	16
DIGITAL 2400 RX (14417)	17
<i>Schematics PB1 (14417)</i>	17
<i>Assembly drawing PB1 (14417)</i>	18
PB2 CONTROL BOARD	19
DIGITAL 1200 RX / 2400 RX (14423)	19
<i>Schematics PB2 (14423)</i>	19
<i>Assembly drawing PB2 (14423)</i>	22
PB3 KEY BOARD (14422)	24
DIGITAL 1200 RX / 2400 RX (14422)	24
<i>Schematics</i>	24
<i>Bill of materials (14422)</i>	25
<i>Assembly drawing PB3 (14422)</i>	26

REMOTE RX.....	27
MECHANICS.....	27
Code numbers:.....	27
Remote cords	27
SCHEMATICS OF 14431	28
BILL OF MATERIALS.....	29
SERVICE NOTES / FAQ'S	29
Photo Cell sensitivity	29
Display or Remote problems.....	29
ASSEMBLING DRAWING	30
LAMP HEADS (115V VERSIONS).....	31
MINI A AND MINI S 115V	32
Part List.....	32
Schematic.....	33
UPGRADE OF THE MINI 1500 TO MINA A OR MINI S (115V VERSION).....	34
RECTANGULAR LAMP HEAD MINI R (115V VERSION)	35
Schematic.....	35
Part List	35
NOTES.....	36

Safety notice

IMPORTANT !

The interior of the generator or compact contain components carrying dangerous levels of electric charge, even though the unit has been disconnected from the mains.

ALWAYS TAKE THE FOLLOWING PRECAUTIONS:

1. Always disconnect it from the mains supply, and discharge the unit before (for generator) and after (for compact) removing the outer cover or housing. This is best achieved with a suitable discharge resistor (code 11931 for 230 V and (11930 for 120 V) fitted to a lamp head plug which may be inserted into a lamp head outlet for generator only. For compact connect the discharge resistor in the flash tube terminals.
2. Take care when opening a generator. Always start by connecting a voltmeter across the storage capacitors, as capacitor drainage may not have occurred due to a fault in the unit.

ACHTUNG GEFAHR !

Auch wenn der Generator vom Netz getrennt ist, können im Innern des Gerätes noch gefährliche elektrische Spannungen vorhanden sein.

ACHTUNG GEFAEHRliche HOCHSPANNUNG:

1. Bevor Sie ein Blitzgerät öffnen, entladen Sie zuerst die Kondensatoren mittels Entladewiderstand (Best, Nr. 11931 für 230 V)
2. Vorsicht beim Öffnen eines Blitzgerätes. Verbinden Sie sofort ein Voltmeter mit den Kondensatoren, denn diese könnten wegen eines anderen Fehlers nicht entladen sein.

ATTENTION DANGER !

Des tensions électriques dangereuses restent présentes, ceci même lorsque l'appareil est déconnecté du secteur.

PRUDENCE LORS DE L'OUVERTURE D'UN GENERATEUR OU COMPACT.

1. Déconnecter l'appareil du réseau et avant de procéder à son ouverture décharger le générateur au moyen du dispositif de décharge (code 11931 pour 230 V) et (11930 pour 120 V). Pour les compacts retirer la poignée et la chemise métallique ou les coques et procéder à la décharge en connectant le dispositif aux bornes du tube flash.
2. Commencer par vérifier la tension aux bornes des condensateurs. Leur drainage peut ne pas avoir eu lieu, la rupture d'un élément ou d'un conducteur peut en être la cause.

Front panel

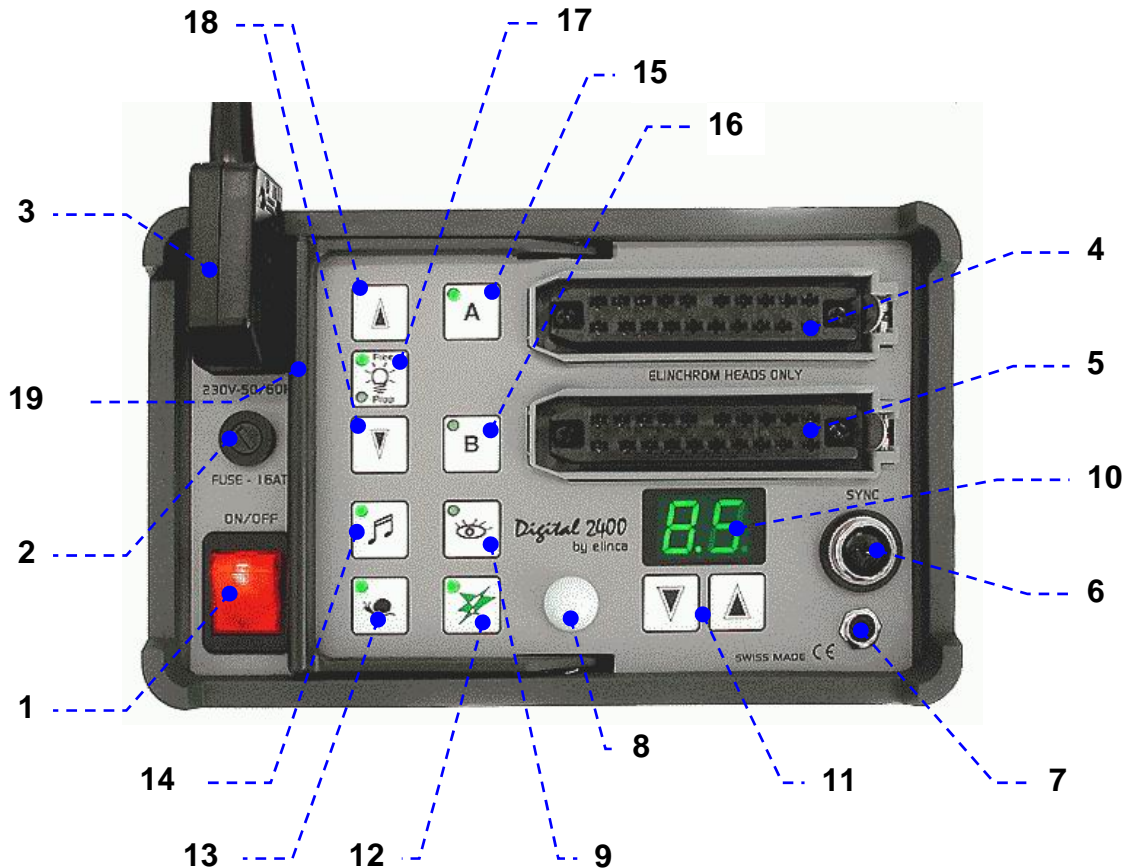

Operating instructions

1. Check that the unit voltage is correct. The unit is manufactured to run on 200 – 245 V, 50/60 Hz for 230 V Version and 100 – 140 V, 50/60 Hz for 115 V version.
2. Switch unit mains switch (1) in OFF position and connect the mains cord (3)
3. Connect ELINCHROM lamp heads.
4. Connect Synchro cable to sockets (6, 7)
5. Switch unit on (1)
6. Select Flash power (11)
7. Check and change configuration buttons, Slave (9), Slow charge mode (13), Audio (14) and modelling lamp (17)
8. Activate only connected outlets (4 , 5)
9. The green Light in open flash button (12) will light up, indication that the unit is ready for operation.

According to the safety regulation: We draw your attention to the fact that this equipment should be used only in a dry environment; it must be protected from dripping water and from extremely dusty conditions. The unit must ALWAYS be plugged into an EARTHED electrical socket.

INDEX

1. Mains Illuminated on/off switch Mains inlet socket
2. Mains fuse (slow blow)
3. Modelling fuse (fast blow)
4. Outlet A (Elinchrom Equipment only)
5. Outlet B (Elinchrom Equipment only)
6. Synchro-socket Amphenol
7. Synchro-socket jack 3,5mm
8. Photocell receptor
9. Slave cell switch on/off
10. Digital power display and charge/discharge indicator
11. +/- Power adjustment in 1/10 f-stops, with ADF
12. Open-flash
13. Slow charge mode
14. Acoustic recharging signal (Beep)
15. Outlet A on/off
16. Outlet B on/off
17. Modelling lamp switch (on/off free or prop)
18. +/- Free modelling power control
19. Handle

Mechanics

Front panel view Digital RX (all)

Version	Unit	Printed front panel foil / Code No.	Main fuse / Code No.(10 fuses)	
			Type	Code No.
230 VAC	Digital 1200 RX	222..022DIGITAL.A	16AT	19057.PC
	Digital 2400 RX	222..023DIGITAL.A	16AT	19057.PC
115 VAC	Digital 1200 RX	222..020DIGITAL	16AT	19057.PC
	Digital 2400 RX	222..021DIGITAL	16AT	19057.PC

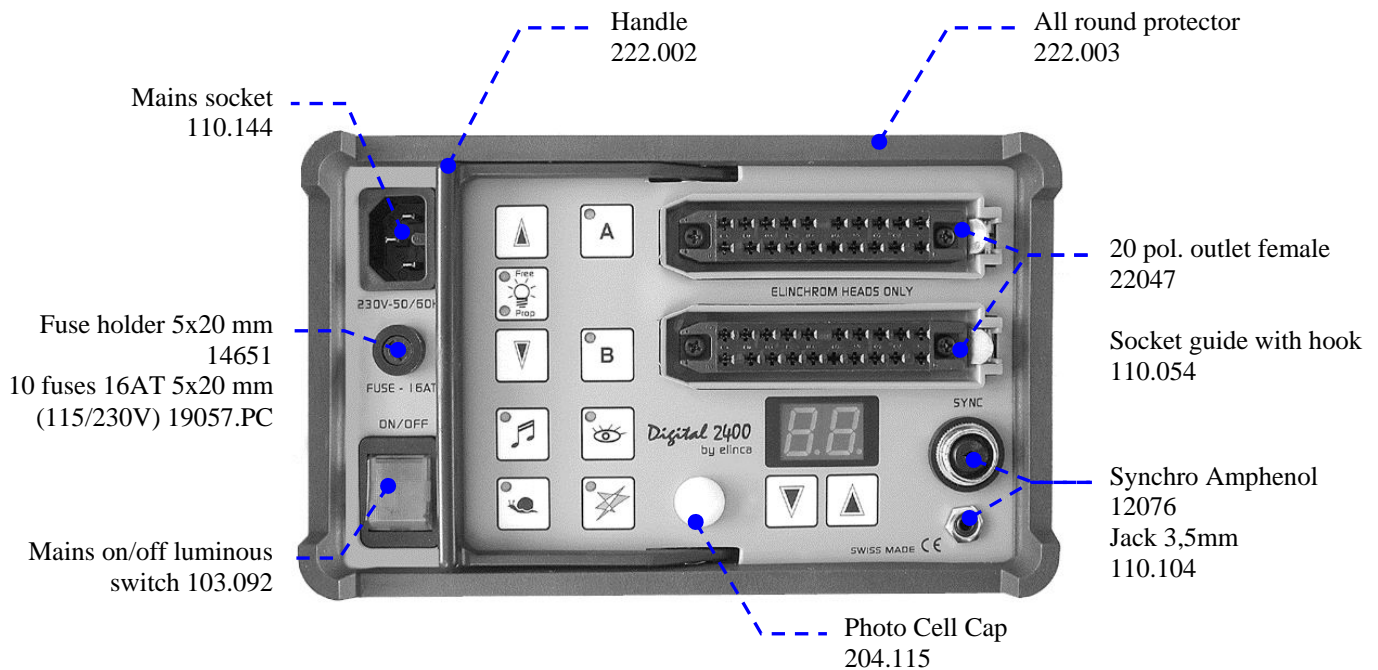

Mechanical Part List

Pos.	Quantity	DESCRIPTION	ELINCA_NO	NOTES
1	1	Housing front part 1200 RX	222.009RX	
2	1	Housing rear part 1200 RX	222.011RX	
3	1	Holder for capacitors 1200 RX	658.003	
4	1	Housing front part 2400 RX	222.010RX	
5	1	Housing front part 2400 RX	222.012RX	
6	1	Holder for capacitors 2400 RX	222.001	
7	2	All round protector	222.003	
8	2	Metal part (U) for fixing capacitor pack	222.013	
9	1	Metal front sheet without panel foil	222.015DIGITAL	
10	1	Metal bottom sheet	222.004	
11	1	Metal left side sheet 1200 RX	222.005	
12	1	Metal left side sheet 2400 RX	222.006	
13	1	Metal right side sheet 1200 RX	222.007	
14	1	Metal right side sheet 2400 RX	222.008	
15	8	Screws M3x6 conic (Chassis)	211.522	
16	16	Screws M3x6 cylinder (Housing)	211.881	
17	3	Distance holder 8x15mm (PB2)	222.016	
18	3	Distance holder 8x85mm (PB2 ↔ PB2)	222.017	
19	3	Screws 3.5x9.5 (PB1 distance holder)	211.804	
20	3	Screws 3.5x32 (PB2 distance holder)	211.802	
21	1	Remote socket complete with connector	501.056	
22	1	L1 earth inductor complete	500.003	
23	1	Handle	222.002	
24	1	10 fuses 16AT 5x20mm (115/230V)	19057	
25	6	Screws M3x6 cylinder (PB3)	211.204	

Service Menu

Unit Service adjustments

Start service menu:

1. Switch unit "On" select minimum power – wait until ready
2. Switch all outlets (A and B) off
3. Press the following buttons together: **MODUP + MODDOWN + BEEP**
4. Service menu is active

Exit service menu without store changes

=> Press **BEEP**

Store changes and exit

=> Press **CELL** when in service menu – all changes are saved

Change value

=> Press push buttons "11" PWRUP or PWRDOWN to change setting

Menus

1. Select Unit Identity / Type

0:	Digital 1200 RX	2.5 – 7.5
1:	Digital 2400 RX	3.5 – 8.5
2:	not used	
3:	not used	

2. Temperature (IGBT)

Display in °C (only read)

3. 50/60Hz Mode

50 (Hz)

60 (Hz)

5. HTT Delay

0..1 => approx. 150..1000 ms delay time of enabling HTT
standard setting is value 2!

Digital 1200 RX: value 1 or 2

Digital 2400 RX: value 2 or 3

Adjustments with ELINCHROM Remote Studio Software E.R.S (PC only)

You need a licensed version of E.R.S. (PC) and a Password to get into the Software Service Menu

Steps

1. Connect the unit (only one) to the E.R.S. "Multi Link" converter and your PC
2. Switch unit on
3. Start E.R.S. Software, Open Port and Scan Net to find the connected unit
4. If found, select EXTRAS then SPECIAL FEATURES and the tab Service
5. Type in the correct SERVICE Password
6. Press "read memory"
7. Do changes and press "write memory" to update unit settings
8. Press "Restart Unit" to activate new unit settings

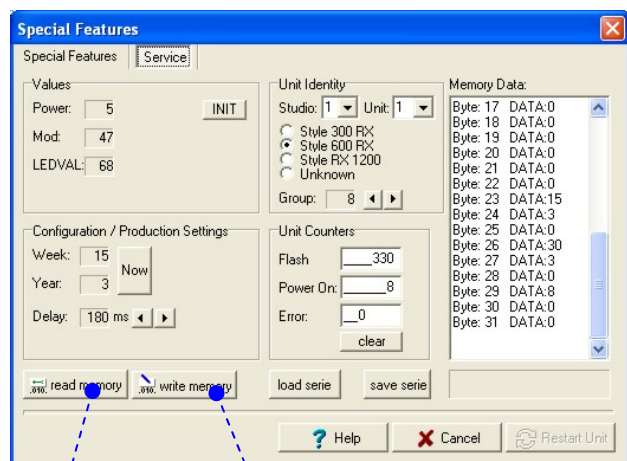

Press read memory to update display

Press write memory to update unit settings with display informations



Trouble Seeking Guide for Digital RX

Important Note

ALWAYS DISCHARGE UNIT BEFORE COMMENCING WORK !
(d  chargez l  appareil avant de commencer la travail)

Known problems

Here is a small list of modifications or solutions with Digital RX troubles.

1. Low Photo cell sensitivity

Check Photo cell circuitry resistor values on PB3 (Key board)

Board 50.0009.02

R123 = 0R, R126 = 100R; R120..R122 = 2,2k, R144 = 22k

Board 50.0009.03

R126 = 100R; R120..R122 = 2,2k, R144 = 22k

2. Error message ‘‘E.4’’ after flash

Problem:

Some flash heads need a longer charge delay time after a high power flash.

Solution:

Increase the charge delay time up to 0.3 to 0.5 seconds

To Do’s:

Start **Unit Service menu** and adjust the charge delay time value one or some steps higher.

3. Error message ‘‘E.4’’ after some minutes at maximum power

Problem:

Unit is switched on and after some minutes Error message ‘E4’ is displayed.

Cause:

Digital RX units needs minimum 210VAC mains supply voltage at maximum power!

To Do’s:

Reduce the flash power 1/10 of a f-stop lower.

4. Error message ‘‘E.6’’ @ Pmin with Digital 2400 RX

Problem:

If power is reduced from Pmax to Pmin, the Error ‘E.6’ will sometimes appear

Solution:

Change Micro U101 on Keyboard with SW upgrade version 80.0004.02 and higher

Error Messages

This error messages are shown by the unit display if an error is detected by the units Micro-Controller.

Error Message Display Value	Description	Check	Note
E 1	Over voltage detected	PB2: Charge circuit => D213, D214, T207, T208, check Repairing help point 2 also PB1: Flash capacitors => unsymmetrical flash capacitors => reform or change faulty capacitor, check Repairing help point 4 also	1
E 2	Over temperature	Unit is overheated – wait cooling	2
E 3	Discharge time out error	PB4: T200 PB2: T1, R4, R5, ZD1;SWTH1	3
E 4	Charge time out error	PB4: Check circuit T207 PB3: Doublers, D5, D6 Check charge delay time in Unit Service menu (increase delay time)	4
E 5	Main supply zero detect error	PB4: Check circuit T203, T204, T205	5
E 6	After charge time out error	PB4: Check D209, circuit T207	6

- Note1: Over voltage detection will protect flash capacitors for possible damage.
Note2: Over temperature is detected Temp.>90°C on heat sink, Normal mode if Temp.<70°C
Note3: Discharge time out after approx. 100 seconds without READY
Note4: Charge time out after approx. 25 seconds without READY – check minimum mains supply voltage >210VAC
Note5: The Micro detects each zero crossing of the mains supply voltage. This signal is needed for triggering modelling lamp.
Note6: After charge time out after approx. 50 seconds without recharge

Repairing Help

1. Fault tracing for blown fuse

- Wrong value fuse
- PB2 Charge circuit T207, T204, T208, T209 or D213, D214 short circuit
- PB1 Charge diodes D1-D6 short circuit
- PB4 Charge driver circuit OK201, OK202
- Photo flash capacitor short circuit

2. Repairing help for Charge Circuit

The charge circuit of Digital RX includes a IGBT Power soft start electronic to protect damage of T207 or T208. On damage of T207 or T208 always check this soft start electronic too and replace faulty components.

On short circuit or damage of T207:

- Always replace T204
- Check R208, R246, R234, R326
- Check D225, C224

On short circuit or damage of T208:

- Always replace T209
- Check R209, R249, R235, R343
- Check D229, C225

3. To trace for a faulty photo flash capacitor

Check the following with power setting to minimum.

Use two voltmeters, one for group A and one for the group B of the flash capacitors

- Place the common probe on the neutral point of test on the PB3, or on the neutral point on the PB4 and the other probe on the ½ voltage test point.
- Place the other Voltmeter on the positive test point on the PB3, and the other probe on the test point ½ voltage (common test point)

Briefly switch the unit "ON" and observe both Voltmeter readings. One side of the charge capacitors will rise, the other will not. This test will determine on which side the faulty component can be found.

4. Replacing a Photo flash capacitor

- Always discharge the unit before commencing work!
- Check that there is no voltage across the new capacitors!

WHEN A PHOTO FLASH CAPACITOR IS BEING REPLACED. IT MUST BE REFORMED

3.1 Reforming capacitors

- Connect two voltmeters for each capacitor group (see point 2. above)
- Set the unit to minimum power
- Flash five times and check capacitor group voltage
- Increase power 1 f-stop higher, flash 5 times and wait 5 minutes
- Increase power 1 f-stop more, flash 5 times again and wait 5 minutes
- Compare flash voltage between group A and B if the difference is smaller than 10V
- If the voltage difference is higher repeat reforming.



3.2 Adjust flash voltage

- Connect two voltmeters for each capacitor group (see point 2. above)
- Set power to minimum
- Turn VR201 clockwise to maximum (Over voltage protection)
- Turn VR200 counter clockwise to minimum (HTD)
- Set power to maximum
- Adjust VR200 clockwise to maximum flash voltage HTD=680V (HTD=voltmeter values A+B)

**counter
clockwise**

3.3 Adjust Over voltage protection

- Connect two voltmeters for each capacitor group (see point 2. above)
- Set power to minimum
- Turn VR201 clockwise to maximum
- Set power to maximum (only if flash voltage is adjusted before => see step 3.2 above)
- Check if capacitor group voltage A or B is lower than 350V (if not, flash voltage is not adjusted or capacitors are not reformed => see step 3.1)
- Adjust capacitor group voltage A or B to maximum 365V with VR200
- Adjust VR201 counter clockwise until "E1" is shown in the unit display => ERROR MODE = Over voltage detection
- Switch unit off
- Turn VR200 counter clockwise to minimum
- Switch unit on and adjust VR200 to a maximum flash voltage HTD=680V (HTD=voltmeter values A+B)

5. Modelling lamp circuitry does not function

- Modelling lamp fuse blown (quick acting)
- Blown blub
- PB2: check V200, V201, T203, D220, D221,..
- PB3: Check Signal MODTRG (100Hz or 120Hz. Pulse 5V)
- PB2: Check Signal MOD when Modelling lamp function is active

6. Fault tracing for discharge resistor failure (E3)

- PB2: Check R263 (3.3k Ohm 25W)
- PB2: Check MOSFET T210 (BUZ51)
- PB2: Check SWTH200 (thermic switch open)

7. Fault tracing for firing faults

- Check Outlets A and B switched on
- Check connected Head (cracked flashtube)
- PB2: check Trigger voltage at capacitors C232 and C233 (0.47 μ F/400V)
- PB1: check Trigger Boost circuitry D7..D9 (short circuit)
- Check READY LED (if off triggering flash tube is not possible)
- PB1: push button S110, T107 and T108

When there is no voltage present across the trigger capacitor try replacing D207, D208 1N4007 Diode. This sometimes reads OK but is often 'leaky' when a voltage is applied.

When there are sometimes trigger faults try replacing C232 and/or C233.

Special circuitry and Graphs

MOSFET charge circuitry

ATTENTION:

Measurement GND (-) is **HIGH VOLTAGE**

LCHRG1:

Measurement GND (-): D213 (Anode)
Gate supply voltage (18V): D225 (Cathode)

LCHRG2:

Measurement GND (-): D214 (Anode)
Gate supply voltage (18V): D229 (Cathode)

Function:

The MOSFET enables and disables flash capacitor charge. The Gate supply voltage is generated by R250, R252, D225 and C224 for LCHRG1 and R253, R251, D229 and C225 for LCHRG2 and is 18VDC. The Gate driver electronic includes a soft start function with T206 and T209.

On damage or malfunction change always T207, T204, D213 for LCHRG1 and T208, T209, D214 together and check all resistor values.

Flash voltage HTD (PB3)

The Style RX series has a absolute stabile flash voltage and f-stop stability. The READY signal is generated only if the flash voltage is greater than 98% of the f-stop setting.

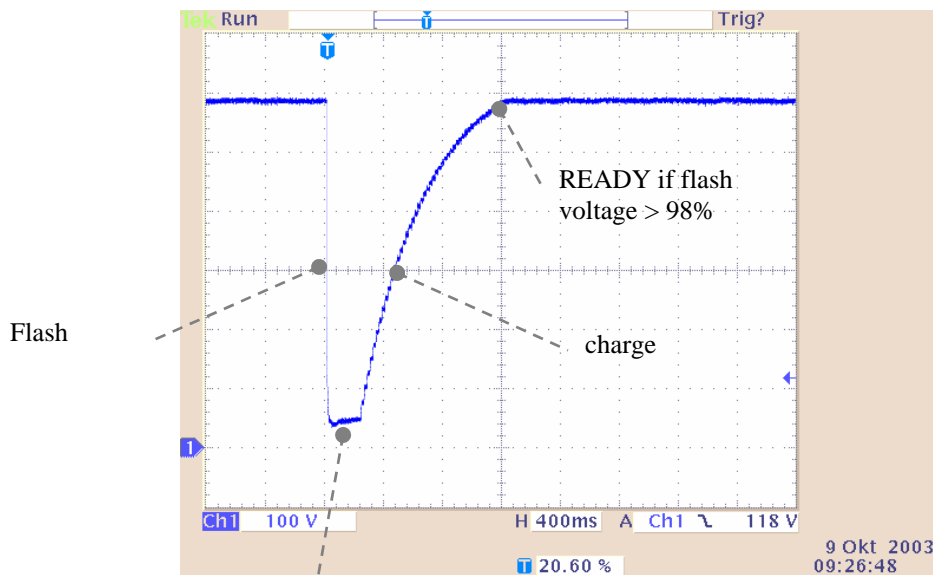

Delay time 150ms - 1.0sec.
(E.R.S. Service Menu)
Standard value approx. 300ms

Printed boards

Overview

Digital 1200 RX / 115V

Board	Code No.	Name	Description
PB1	14411	CAP / POWER	Capacitor bank 1200 Ws
PB2	14423	CTRL	Control board
PB3	14422	KBD	Key board

Digital 2400 RX / 115V

Board	Code No.	Name	Description
PB1	14417	CAP / POWER	Capacitor bank 2400 Ws
PB2	14423	CTRL	Control board
PB3	14422	KBD	Key board

Bill of materials PB1 (14411)

Pos.	Quantity	DESIGNATOR	PARTTYPE	ELINCA_NO	DESCRIPTION
1	2	C1, C2	160U/250VAC	104.120	Doubler 160uF/250VAC
2	2	C3, C4	160U/250VAC	104.120	Doubler 160uF/250VAC
3	8	C5, C6, C7, C8, C9, C10, C11, C12	2600U/360V-E	14342	FLASH Capacitor
4	3	D1, D7, D8	70AR/800	105.080	Diode 70A/800V
5	3	D2, D3, D6	70A/800	105.087	Diode 70A/800V
6	3	J1, J2, J3	6,3X0,8	112.078	6,3x0,8 stehend
7	3	J4, J5, J6	2,8X0,8	112.076	2,8x0,8 stehend
8	2	R1, R2	560K/2500V	121.564	Resistor 560K/2500V
9	2	R3, R4	27K/10W	111.052	Resistor 27k 10W

Assembly drawing PB1 (14411)

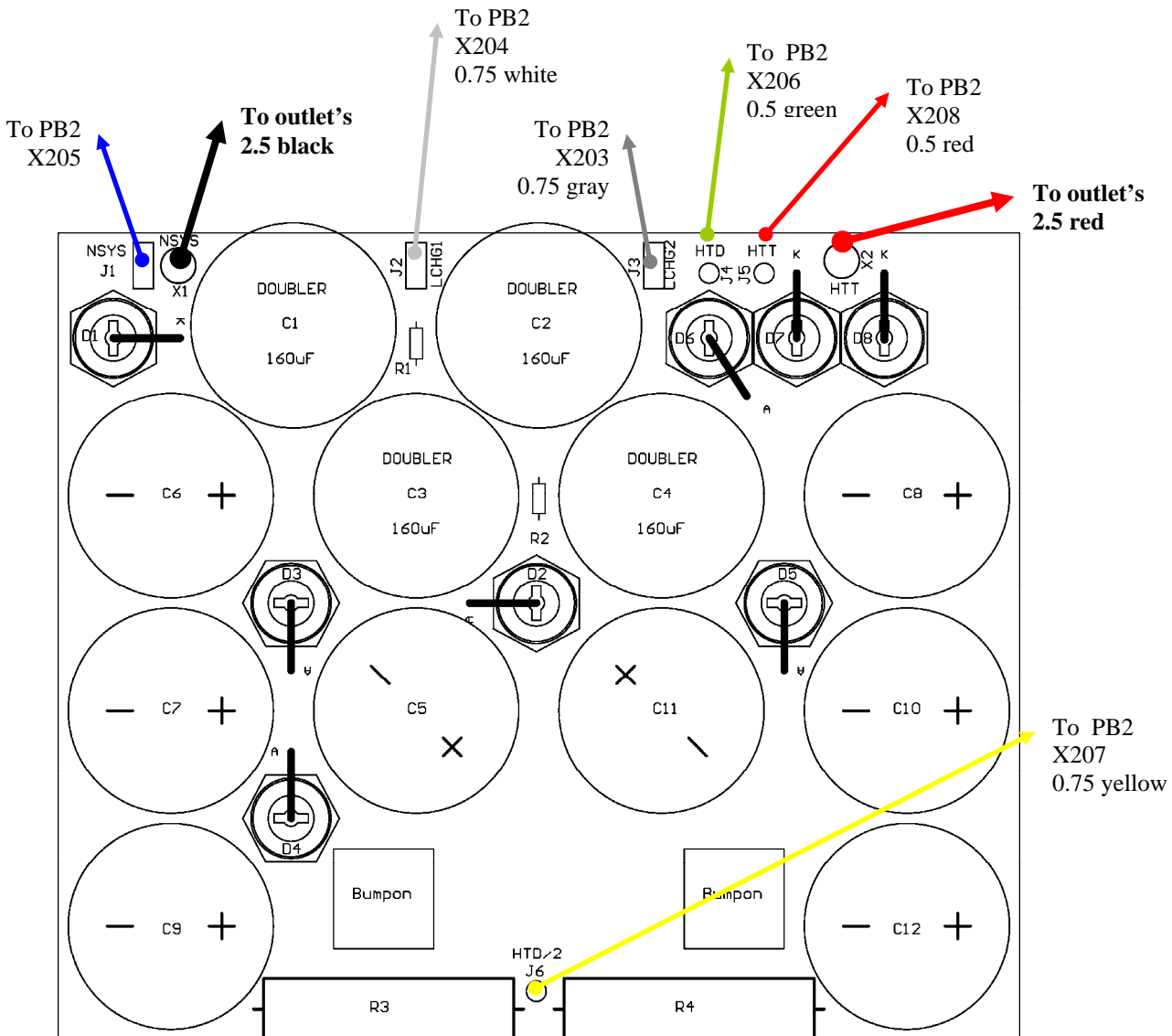

Digital 2400 RX (14417) Schematics PB1 (14417)

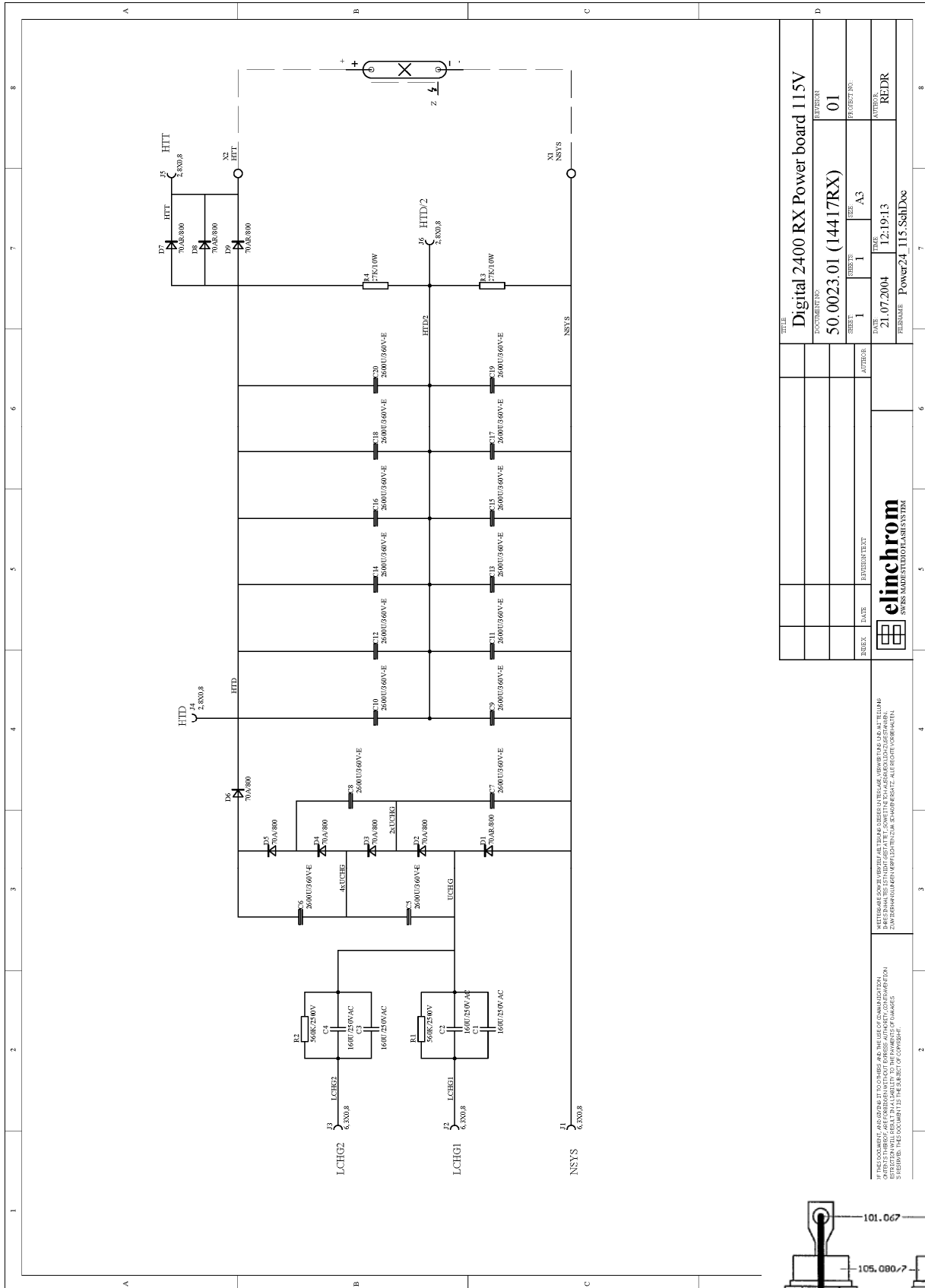

TITLE		Digital 2400 RX Power board 115V	
DOCUMENT NO.		50.0023.01 (14417RX)	
SHEET	REV.	PROJ. NO.	
1	A.3		
DATE	DESIGNER	DATE	REV.
21.07.2004		12.19.13	
TELEPHONE	Power24_115_SchDoc		

WHILE THE DOCUMENT IS BEING PREPARED, THE USER SHALL BE RESPONSIBLE FOR THE CORRECTNESS OF THE INFORMATION PROVIDED. THE USER SHALL BE RESPONSIBLE FOR THE CORRECTNESS OF THE INFORMATION PROVIDED. THE USER SHALL BE RESPONSIBLE FOR THE CORRECTNESS OF THE INFORMATION PROVIDED.

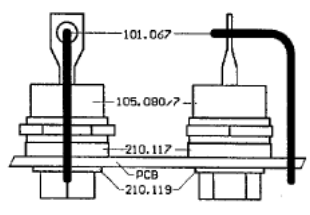

Bill of materials PB1 (14417)

Pos.	Quantity	DESIGNATOR	PARTTYPE	ELINCA_NO	DESCRIPTION
1	2	C1, C2	160U/250VAC	104.120	Doubler 160uF/250VAC
2	2	C3, C4	120U/250VAC	104.120	Doubler 160uF/250VAC
3	16	C5, C6, C7, C8, C9, C10, C11, C12, C13, C14, C15, C16, C17, C18, C19, C20	2600U/360V-E	14342	FLASH Capacitor
4	4	D1, D7, D8, D9	70AR/800	105.080	Diode 70A/800V
5	3	D2, D3, D6	70A/800	105.087	Diode 70A/800V
6	3	J1, J2, J3	6,3X0,8	112.078	6,3x0,8 stehend
7	3	J4, J5, J6	2,8X0,8	112.076	2,8x0,8 stehend
8	2	R1, R2	560K/2500V	121.564	Resistor 560K/2500V
9	2	R3, R4	27K/10W	111.052	Resistor 27k 10W

Assembly drawing PB1 (14417)

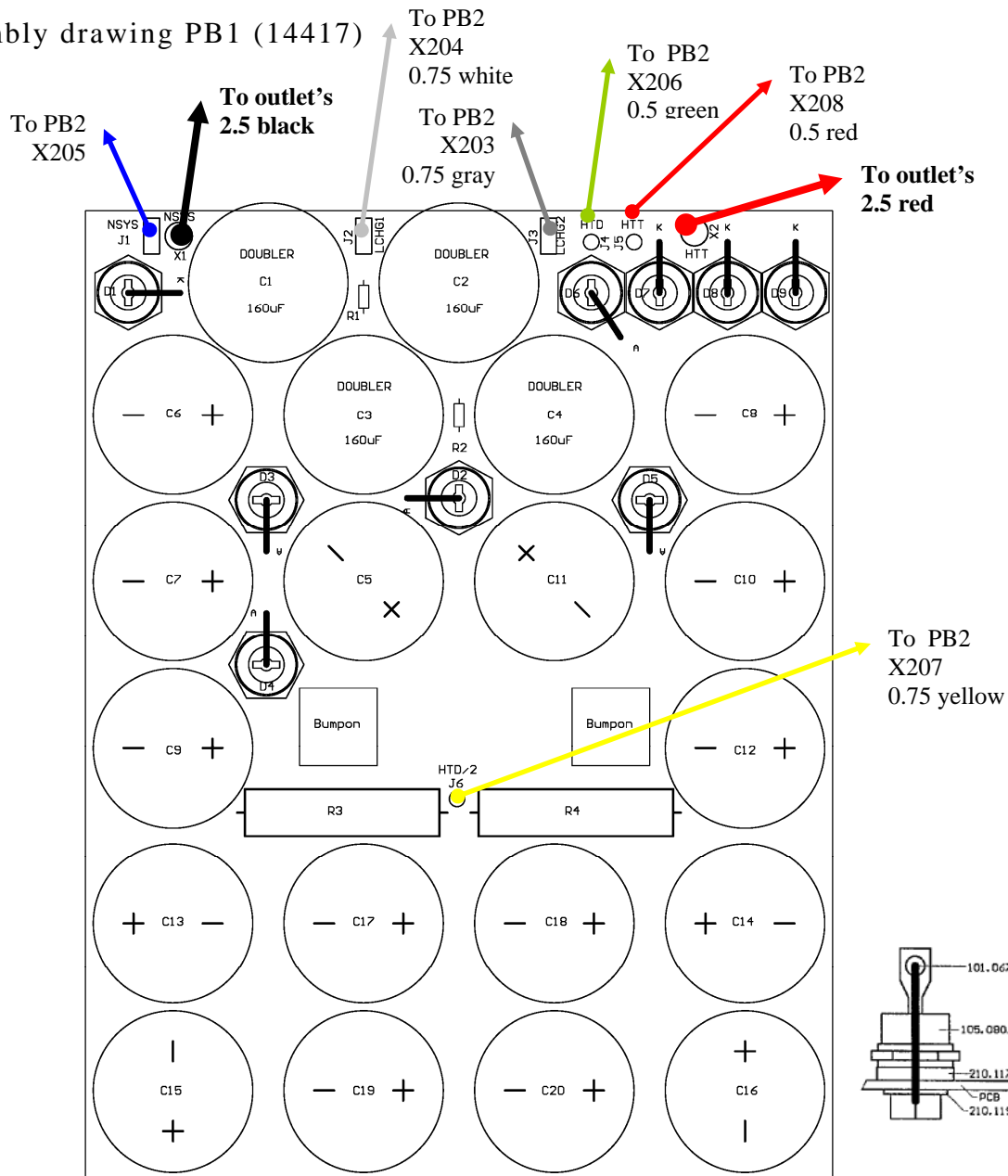

PB2 Control board

Digital 1200 RX / 2400 RX (14423)

Schematics PB2 (14423)

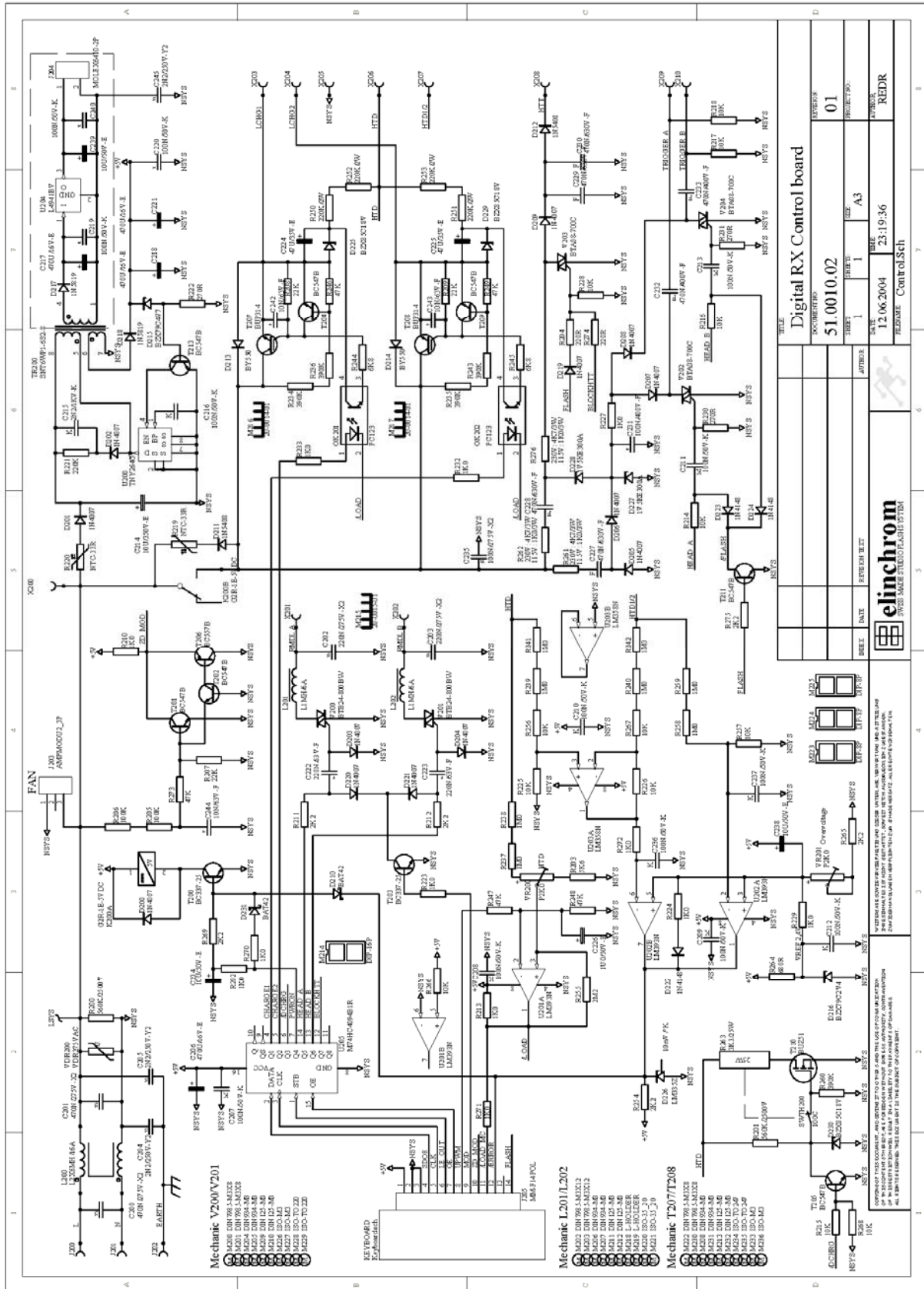

Digital RX Control board			
DOCUMENT NO	51.0010.02		
REVISION	1	DATE	12.06.2004
DESIGNER	A3	APPROVED	23.19.36
REVISION	01	REVISION	REDR
elinchrom SWISS MADE STEELROLL SYSTEM			

Bill of materials PB2 (14423)

Pos.	Quantity	DESIGNATOR	PARTTYPE	ELINCA_NO	DESCRIPTION
1	2	C200, C201	470N/275V-X2	104.131	Capacitor X2
2	2	C202, C203	220N/275V-X2	104.130	Capacitor X2
3	3	C204, C205, C245	2N2/250V-Y2	104.106	Capacitor Y2
4	4	C206, C217, C218, C221	470U/16V-E	104.053	ELKO
5	13	C207, C208, C209, C210, C211, C212, C213, C216, C219, C220, C236, C237, C240	100N/50V-K	104.015	Capacitor Keramik B37987-F5
6	1	C214	10U/350V-E		Capacitor
7	1	C215	2N2/1KV-K		Capacitor Ceramic
8	2	C222, C223	220N/63V-F		Capacitor MKS2
9	2	C224, C225	47U/35V-E	104.033	ELKO
10	1	C226	1U0/50V-E		ELKO >=35V
11	4	C227, C228, C229, C230	470N/630V-F	104.024	Epoxid Capacitor
12	1	C231	100N/400V-F		Capacitor MKP4 400V
13	2	C232, C233	470N/400V-F		Capacitor MKS4
14	3	C234, C238, C239	10U/50V-E		ELKO
15	1	C235	100N/275V-X2	104.129	Capacitor X2
16	3	C242, C243, C244	10N/63V-F	104.074	Capacitor MKS2
17	13	D200, D201, D202, D203, D204, D205, D206, D207, D208, D209, D219, D220, D221	1N4007	14009	Diode
18	2	D210, D231	BAT42		Diode
19	2	D211, D212	1N5408	14430	Diode
20	2	D213, D214	BY550	105.050	Diode 1000V 5A
21	1	D215	BZX79C4V7	105.117	Diode Zener
22	1	D216	BZX79C2V4		Diode Zener
23	2	D217, D218	1N5819		Shottky diode
24	3	D222, D223, D224	1N4148	105.051	Diode
25	3	D225, D229, D230	BZX85C18V		Diode Zener
26	1	D226	LM335Z	105.201	Sensor Temp.
27	2	D227, D228	1V5KE300A		Diode
28	1	J203	AMPMODU2_3P		Connector male 3P 90°
29	1	J204	MOLEX6410-2P	110.072	Connector 2P LP
30	1	J205	MM-F14POL		Mico Match Federleite 14POL
31	1	K200	G2R-1E-5VDC	100.039	Relais 16A 4000VA
32	1	L200	L2X6MH/16A		Inductor 2x 6mH 16A
33	2	L201, L202	L1MH/6A		Thyristor Inductor 1000W
34	4	M200, M201, M222, M230	DIN7985-M3X8	211.203	SCREW DIN7985 M3x8
35	2	M202, M203	DIN7985-M3X12		SCREW DIN7985 M3x12
36	6	M204, M205, M206, M207, M208, M231	DIN934-M3	203.031	Nut DIN934-M3
37	6	M209, M210, M211, M212, M213, M232	DIN125-M3		Washer M3
38	1	M214	DIP-16P		Dual Inline Socket 16P 7,62mm
39	1	M215	20-0015-01	222.034RX	Heatsink Digital RX (Mod)
40	2	M216, M217	20-0014-01	222.014RX	Heatsink Digital RX IGBT (Charge)
41	2	M218, M219	L-HOLDER		Inductor Holder for HARTU 1mH/4,5A
42	2	M220, M221	ISO-35_20		Insulation washer 19,2/34/1,5PA

43	3	M223, M224, M225	DIP-8P	110.092	Dual Inline Socket 8P 7,62mm
44	4	M226, M227, M233, M236	ISO-M3		Insulation TO220 M3
45	2	M228, M229	ISO-TO220		Insulation TO220
46	2	M234, M235	ISO-TO247		Insulation TO247
47	2	OK201, OK202	PC123	105.139	Transistor Optocoupler
48	2	R200, R201	560K/2500V	121.564	Resistor 560K/2500V
49	12	R202, R210, R213, R223, R224, R227, R229, R232, R233, R270, R271, R272	1K0	121.102	Resistor 1%
50	1	R203	5K6		Resistor 1%
51	2	R204, R274	220R	121.221	Resistor 1%
52	2	R205, R206	100K	121.104	Resistor 1%
53	3	R207, R208, R209	22K	121.223	Resistor 1%
54	6	R211, R212, R254, R265, R269, R275	2K2	121.222	Resistor 1%
55	13	R214, R215, R216, R217, R218, R225, R226, R228, R256, R257, R266, R267, R268	10K	121.103	Resistor 1%
56	2	R219, R220	NTC-33R		NTC 33R
57	1	R221	220K		Resistor 1%
58	3	R222, R230, R231	270R		Resistor 1%
59	5	R234, R235, R236, R243, R260	390K	121.394	Resistor 1%
60	8	R237, R238, R239, R240, R241, R242, R258, R259	1M0	121.105	Resistor 1%
61	2	R244, R245	6K8		Resistor 1%
62	5	R246, R247, R248, R249, R273	47K	121.473	Resistor 1%
63	4	R250, R251, R252, R253	220K/2W		Resistor 2W 2%
64	1	R255	2M2		Resistor 1%
65	3	R261, R262, R276	1K0/3W		Resistor 3W
66	1	R263	3K3/25W	111.524	Resistor 25W
67	1	R264	680R		Resistor 1%
68	1	SWTH200	100C	14032	Thermoswitch 100°C
69	2	T200, T203	BC337-25		Transistor
70	7	T201, T202, T204, T205, T209, T211, T213	BC547B	14012	Transistor
71	1	T206	BC557B	14013	Transistor
72	2	T207, T208	BUP314	105.154	IGBT 35A
73	1	T210	BUZ51	14033	MOSFET
74	1	TR200	SNT6WP1-6S2-8		Transformer SNT 6VA 85-265V 1x8V 1x6V
75	1	U200	TNY264G		Switch Mode Controller 6W
76	2	U201, U202	LM393N		COMP
77	1	U203	LM358N		OP 2F
78	1	U204	L4941BV		Regulator LDO 5,0V
79	1	U205	M74HC4094B1R		Seriell-parallel converter
80	2	V200, V201	BTB24-800BW	105.047	Triac
81	3	V202, V203, V204	BTA08-700C		Triac
82	1	VDR200	VDR275VAC	111.061	Varistor 275VAC
83	2	VR200, VR201	P2K0	109.023	Trimmer

Assembly drawing PB2 (14423)

Top View PB2

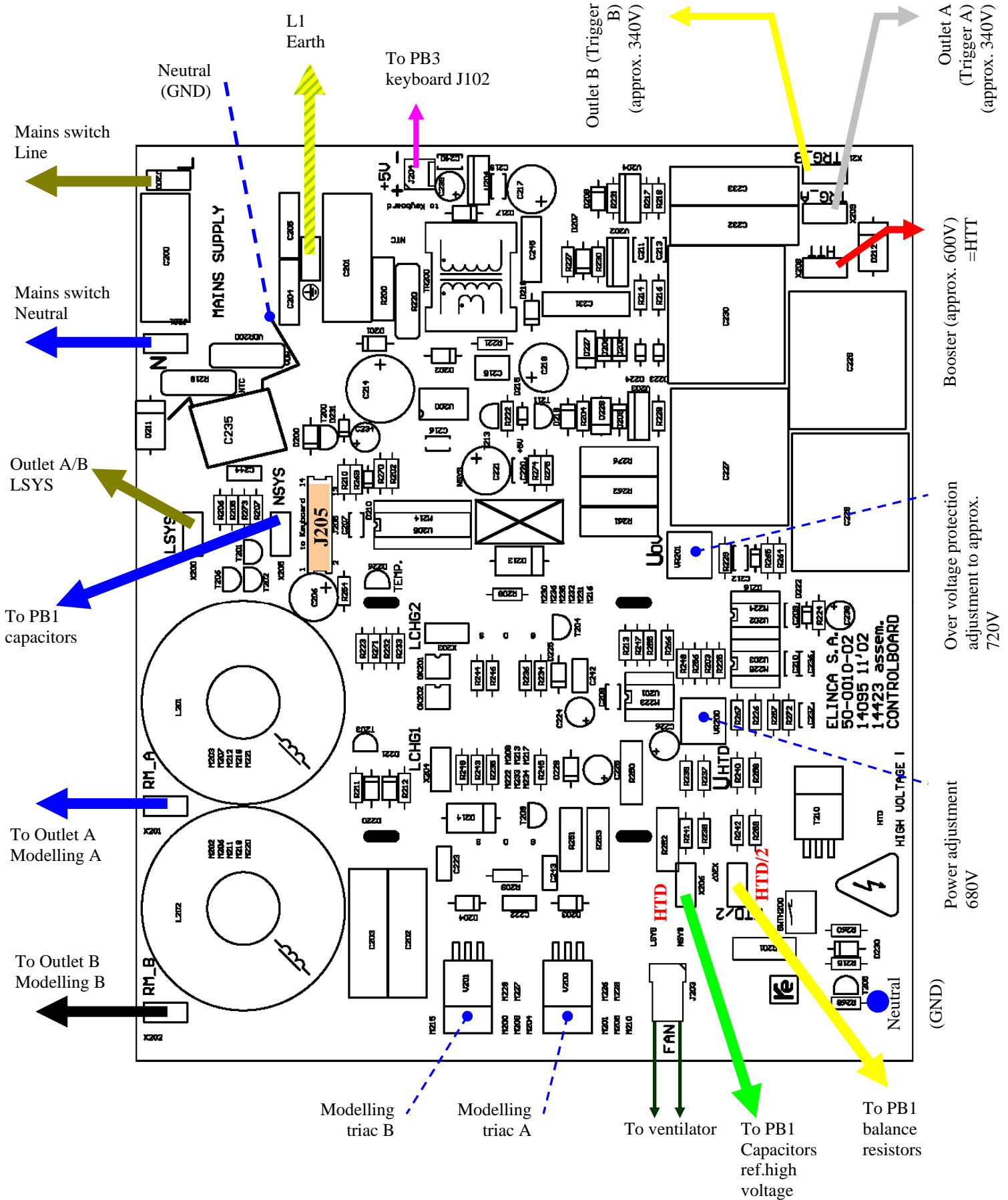

Bottom View PB2

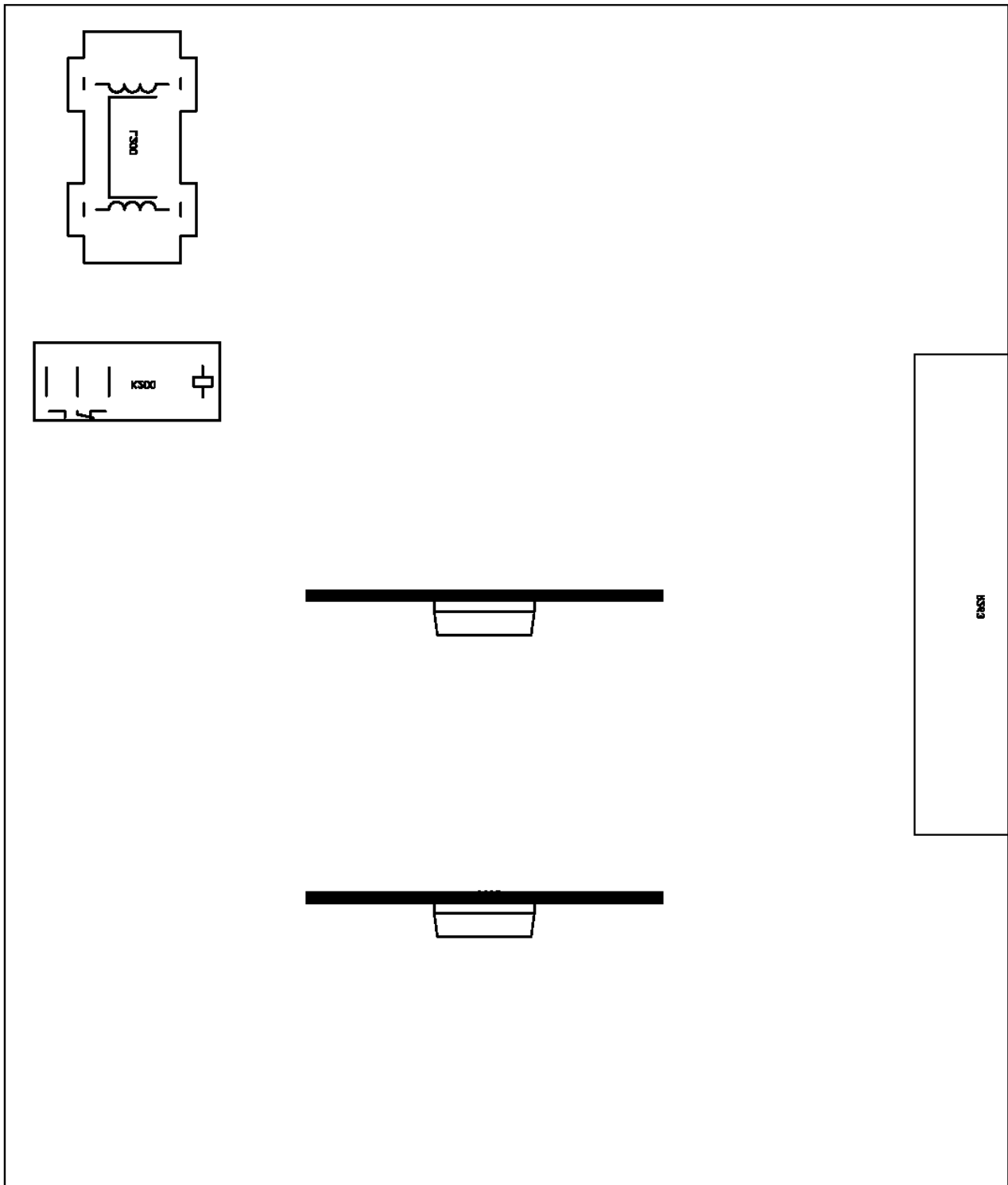

PB3 Key board (14422) Digital 1200 RX / 2400 RX (14422) Schematics

Note !
The electronic board is part of
Exchange Service

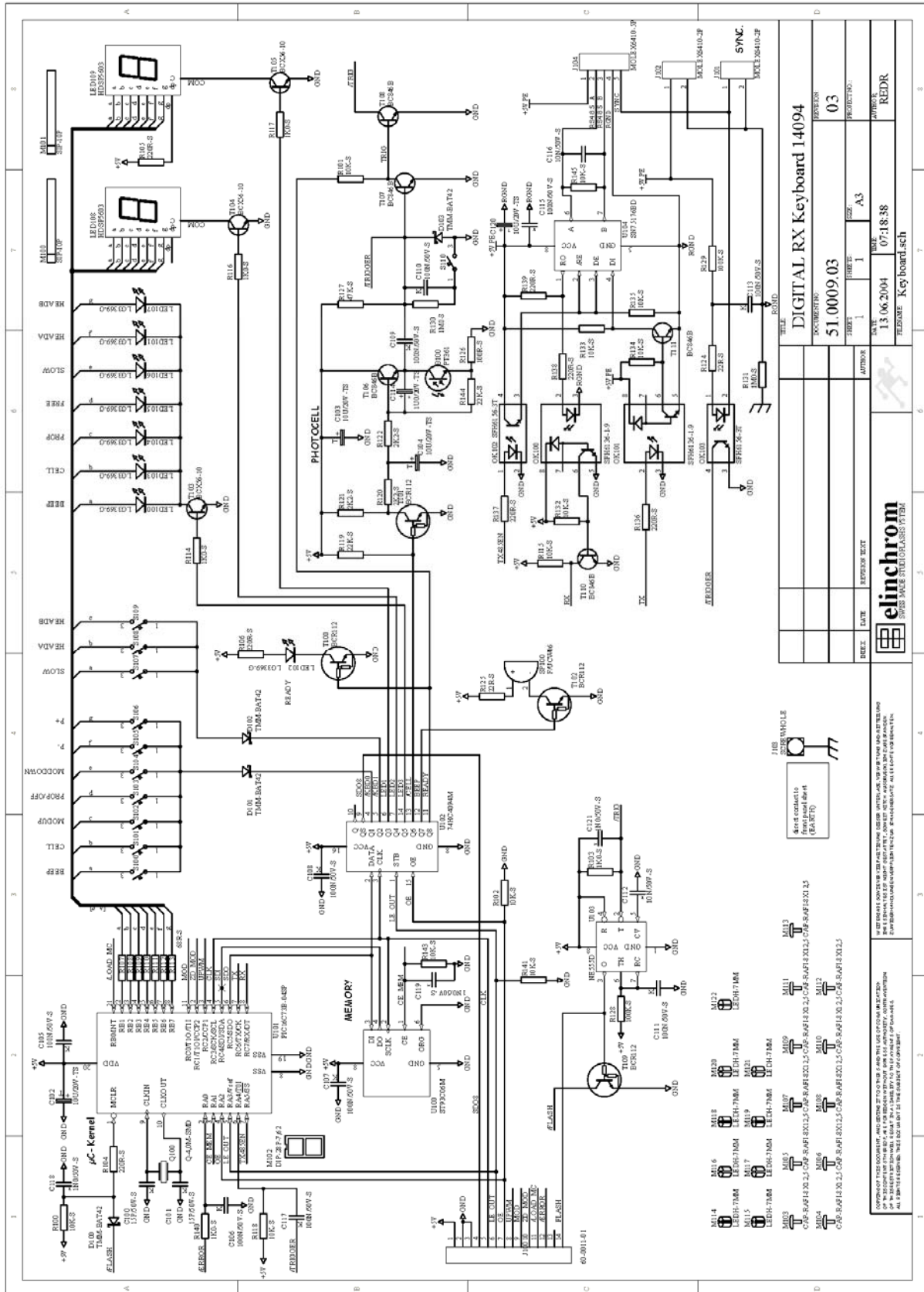

Bill of materials (14422)

Pos.	Quantity	DESIGNATOR	PARTTYPE	ELINCA_NO	DESCRIPTION
1	1	B100	PT361	105.028	Sensor Photo
2	2	C100, C101	15P/50V-S		Capacitor SMD
3	4	C102, C103, C104, C120	10U/20V-TS		Capacitor Tantal SMD
4	10	C105, C106, C107, C108, C109, C110, C111, C113, C115, C117	100N/50V-S		Capacitor SMD
5	2	C112, C116	10N/50V-S		Capacitor SMD
6	1	C114	1U0/20V-TS		Capacitor Tantal SMD
7	3	C118, C119, C121	1N0/50V-S		Capacitor SMD
8	4	D100, D101, D102, D103	TMM-BAT42		Shottky SMD
9	1	J100	60-0011-01		Flat Cable 14P AWG28 100mm
10	2	J101, J102	MOLEX6410-2P	110.072	Connector 2P LP
11	1	J104	MOLEX6410-5P		Connector 5P LP
12	8	LED100, LED101, LED102, LED103, LED104, LED105, LED106, LED107	LG3369-G	108.031	3mm LED
13	2	LED108, LED109	HDSP5603	105.158	LED 7SEG green
14	2	M100, M101	SIP-10P		Single Inline Socket 10P
15	1	M102	DIP-28P-7,62		Dual Inline Socket 28P 7,62mm
16	2	OK100, OK101	SFH6136-1-9		Optocoupler
17	2	OK102, OK103	SFH6156-3T		Optocoupler Transistor SMD
18	1	Q100	Q-4,0M-SMD		Quarz SMD
19	12	R100, R101, R102, R115, R118, R132, R133, R134, R135, R141, R143, R145	10K-S		Resistor 1% SMD
20	5	R103, R114, R116, R117, R140	1K0-S		Resistor 1% SMD
21	7	R104, R105, R106, R136, R137, R138, R139	220R-S		Resistor 1% SMD
22	7	R107, R108, R109, R110, R111, R112, R113	68R-S		Resistor 1% SMD
23	2	R119, R144	22K-S		Resistor 1% SMD
24	3	R120, R121, R122	2K2-S		Resistor 1% SMD
25	2	R124, R125	22R-S		Resistor 1% SMD
26	1	R126	100R-S		Resistor 1% SMD
27	1	R127	47K-S		Resistor 1% SMD
28	2	R128, R129	100K-S		Resistor 1% SMD
29	2	R130, R131	1M0-S		Resistor 1% SMD
30	11	S100, S101, S102, S103, S104, S105, S106, S107, S108, S109, S110	RACON-8H-S		Push button SMD
31	1	SP100	F/UCW06	107.025	Buzzer 5V with electronic
32	4	T100, T101, T102, T109	BCR112		Transistor SMD R1/R2=4k7
33	3	T103, T104, T105	BCX56-10		SMD NPN Transistor 1A
34	5	T106, T107, T108, T110, T111	BC846B		Transistor SMD
35	1	U100	ST93C46M		EEPROM SMD
36	1	U101	PIC16F73-I/SP	105.145	uC Microchip Flash 28 pol. Out +/- 200mA
37	1	U102	74HC4094M		Seriell-parallel converter SMD
38	1	U103	NE555D		TIMER SMD
39	1	U104	SN75176BD		RS485 Bus driver SMD

Assembly drawing PB3 (14422)

Top View PB3

To PB2
control board J205

Note !
The electronic board is part of
Exchange Service

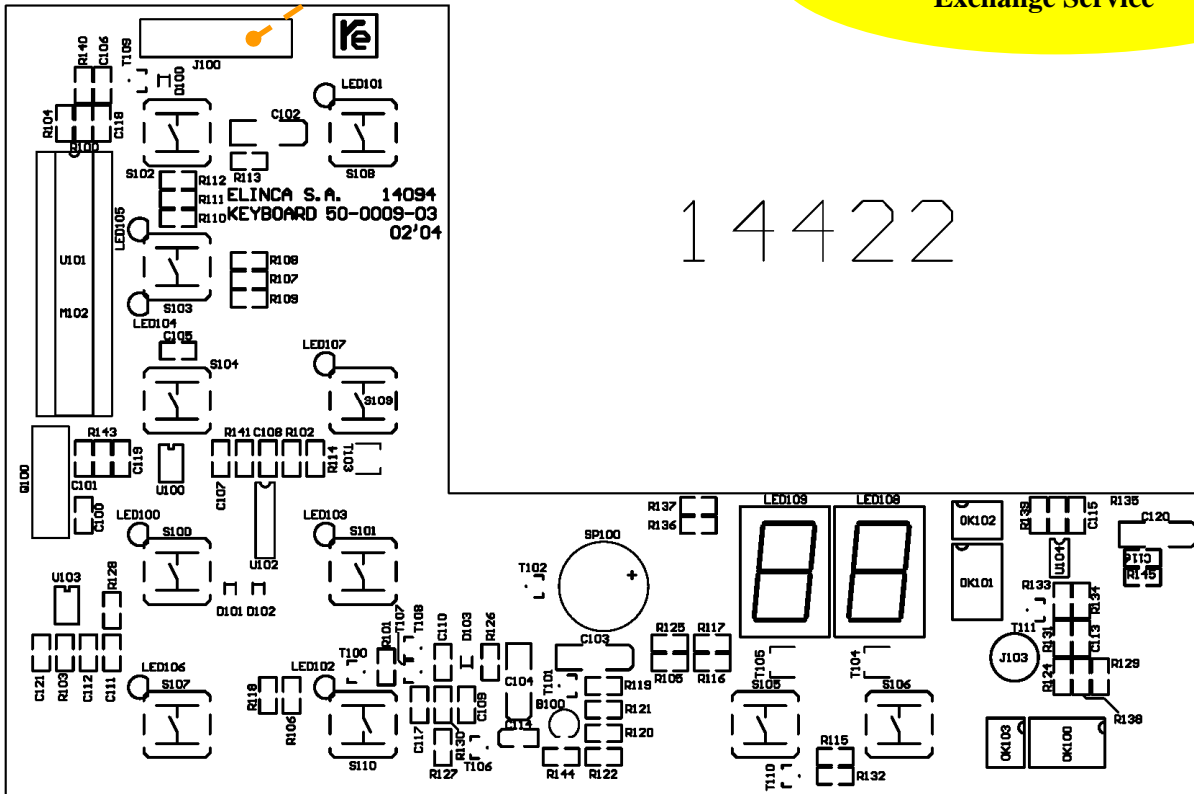

Bottom View

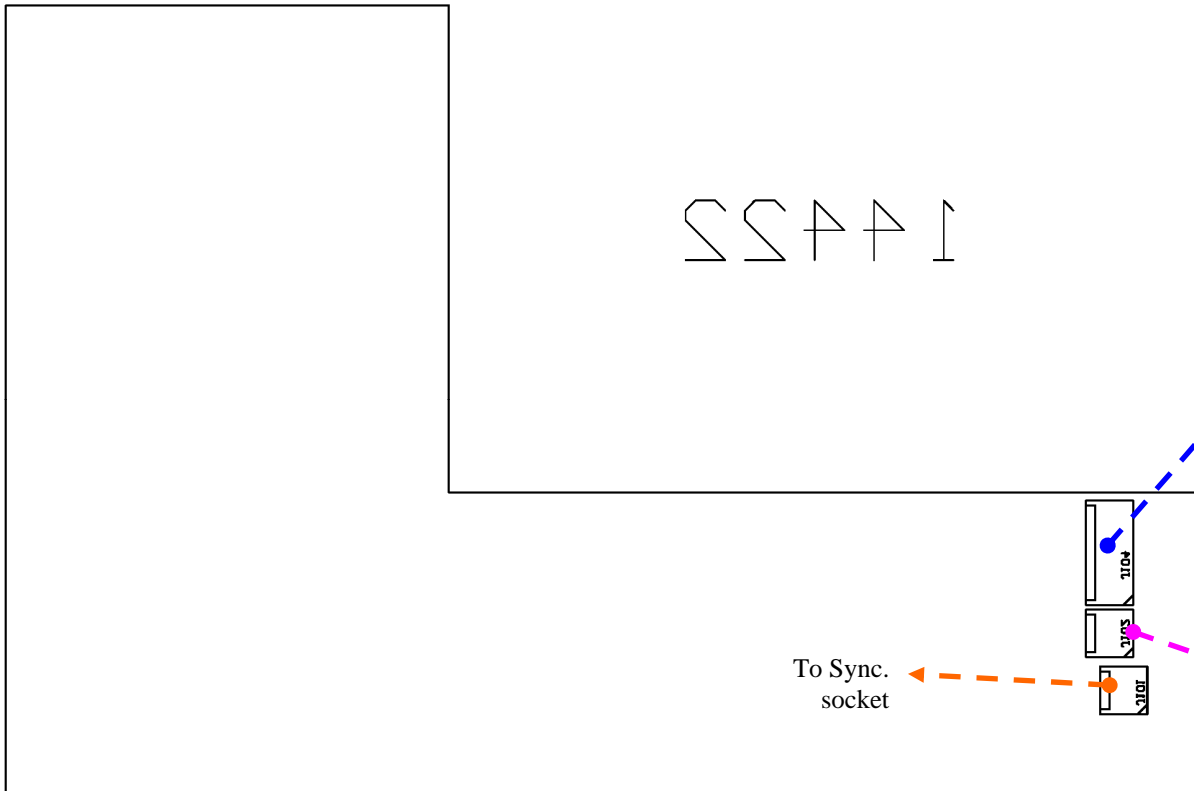

Remote RX

Mechanics

Code numbers:

19340 Universal Digital Remote for all RX Units

- **Style 300 RX**
- **Style 600 RX**
- **Style 1200 RX**
- **Digital 1200 RX**
- **Digital 2400 RX**
- **Ranger RX**
- **Ranger RX Speed (AS)**
- **and future products**

Remote cords

All cables with 5 poles RX connector

- 111.000 Remote cord 1.2m length
- 111.001 Remote cord 2.4m length
- 111.002 Remote cord 4.8m length
- 111.003 Remote cord 9.6m length
- 111.004 Remote cord 19.2m length



- Case complete casing
224.021DIGITAL-PC-Smoke
- 4x Screws KA22x8 (vis)
211.885
- 2x Inner distance holder
204.031
- Electronic board (assembled)
14431

Schematics of 14431

Note !
The electronic board is part of
Exchange Service

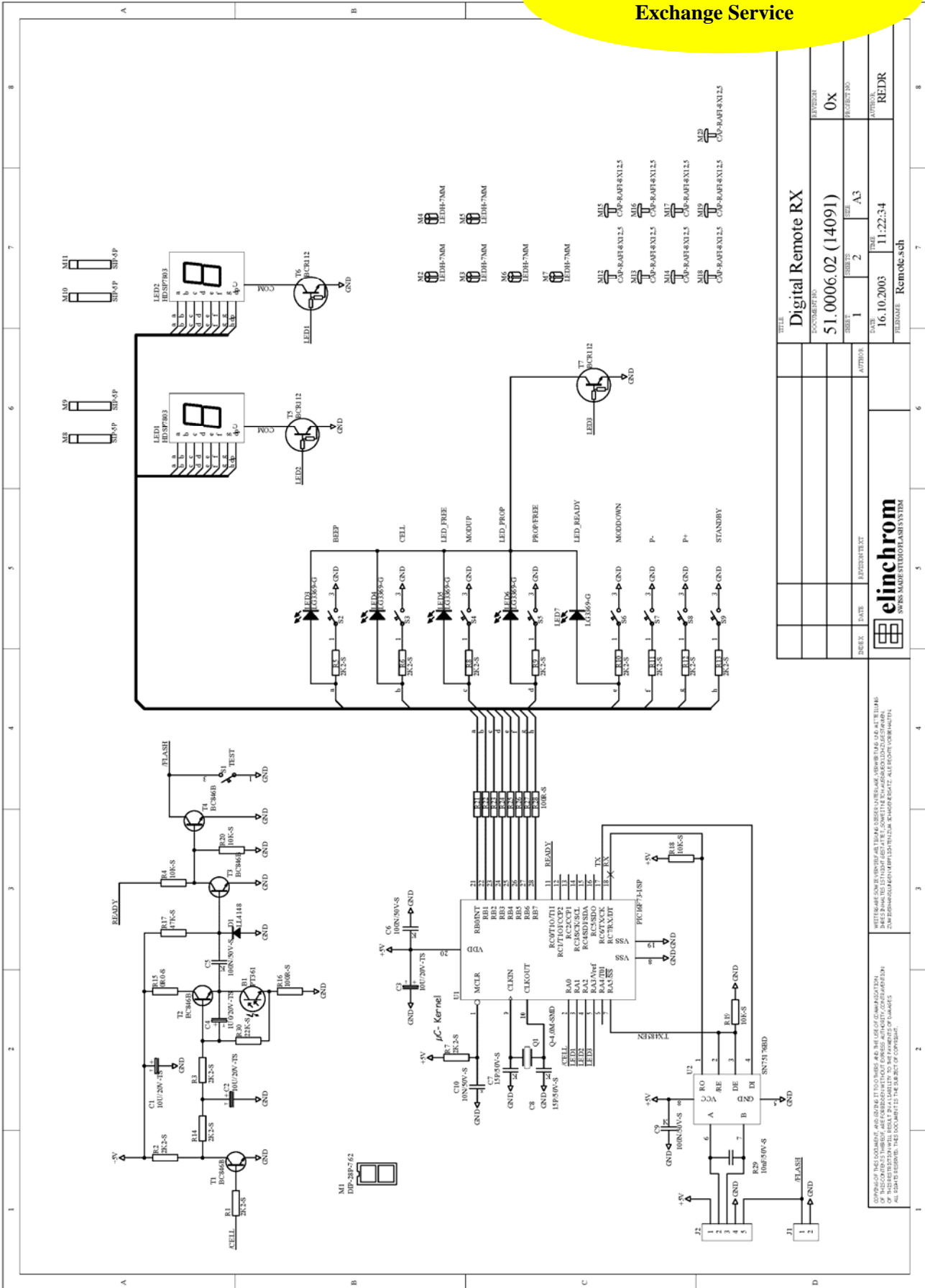

TITLE		Digital Remote RX	
DOCUMENT NO		51.0006.02 (14091)	
REVISION	0X	DATE	16.10.2003
DESIGNER		AUTHOR	REDR
SHEET	1	SHEET	2
SCALE	A3	FILENAME	Remote.sch

elichrom
SWISS MADE IN THE HEIMLIKEN

REVISIONS: 01: INITIAL DESIGN AND DEVELOPMENT. 02: REVISION FOR THE ADDITION OF THE FLASH MEMORY. 03: REVISION FOR THE ADDITION OF THE KEYPAD. 04: REVISION FOR THE ADDITION OF THE BATTERY. 05: REVISION FOR THE ADDITION OF THE DISPLAY. 06: REVISION FOR THE ADDITION OF THE MICROCONTROLLER. 07: REVISION FOR THE ADDITION OF THE KEYPAD. 08: REVISION FOR THE ADDITION OF THE BATTERY. 09: REVISION FOR THE ADDITION OF THE DISPLAY. 10: REVISION FOR THE ADDITION OF THE MICROCONTROLLER.

Bill of Materials

Note: This board is part of exchange service

This board is not repairable by the importer, it is deliverable only in standard exchange with a guarantee of 2 years (after 2 years guarantee expired , deliverable to a special price)

Quantity	Components	Comment	ELINCA_N°	DESCRIPTION
1	R15	0R0-S		0R bridge SMD
3	C5, C6, C9	100N/50V-S		Capacitor SMD
9	R16, R21, R22, R23, R24, R25, R26, R27, R28	100R-S		Resistor 1% SMD
4	R4, R18, R19, R20	10K-S		Resistor 1% SMD
2	C10, R29	10N/50V-S		Capacitor SMD
3	C1, C2, C3	10U/20V-TS		Capacitor Tantal SMD
2	C7, C8	15P/50V-S		Capacitor SMD
1	C4	1U0/20V-TS		Capacitor Tantal SMD
1	R30	22K-S		Resistor 1% SMD
13	R1, R2, R3, R5, R6, R7, R8, R9, R10, R11, R12, R13, R14	2K2-S		Resistor 1% SMD
1	R17	47K-S		Resistor 1% SMD
4	T1, T2, T3, T4	BC846B		Transistor SMD
3	T5, T6, T7	BCR112		Transistor SMD R1/R2=4k7
1	M1	DIP-28P-7,62		Dual Inline Socket 28P 7,62mm
2	LED1, LED2	HDSP7803		LED 7SEG green
5	LED3, LED4, LED5, LED6, LED7	LG3369-G		3mm LED
1	D1	LL4148		Diode SMD
1	U1	80.0005.02		uC Microchip Remote RX
1	B1	PT361	105.028	Sensor Photo
1	Q1	Q-4,0M-SMD		Quarz SMD
9	S1, S2, S3, S4, S5, S6, S7, S8, S9	RACON-8H-S		Push button SMD
1	U2	SN75176BD		RS485 Bus driver SMD
9	M12, M13, M14, M15, M16, M17, M18, M19, M20	CAP-RAFI-8X12,5	103.102 (female type) 103.105 (male type)	Push button cap 8mm

Service Notes / FAQ's

Photo Cell sensitivity

**Check Photocell circuitry resistors for correct values
R3, R14, R15, R16**

Display or Remote problems

Check if R29 = 10nF !

(or R29 = 10k parallel 10nF)

Assembling drawing

Note !
The electronic board is part of Exchange Service

This board is not repairable by the importer, it is deliverable only in standard exchange with a guarantee of 2 years (after 2 years guarantee expired , deliverable to a special price)

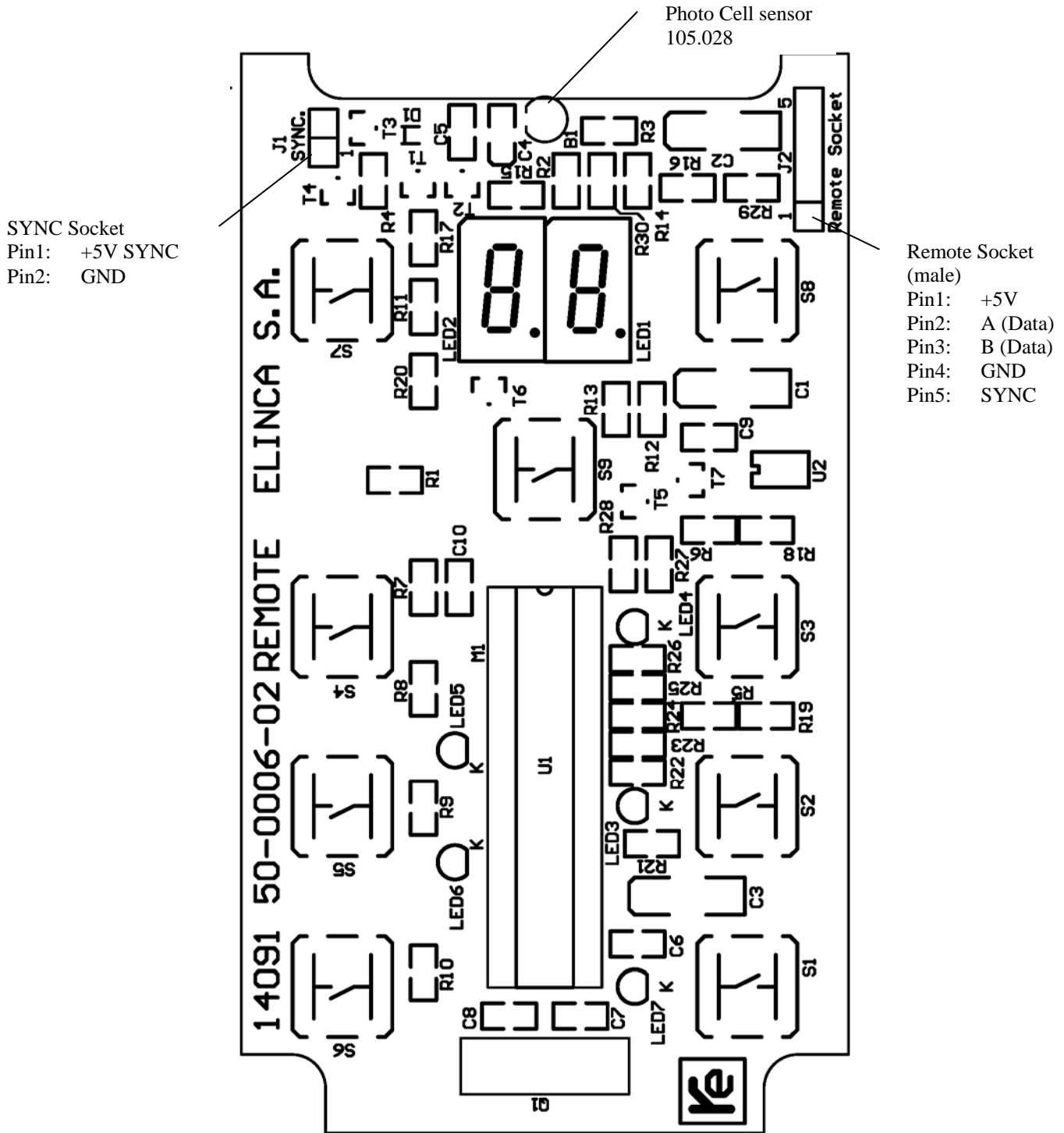

Lamp heads (115V versions)

Mini S – Mini A – Mini R

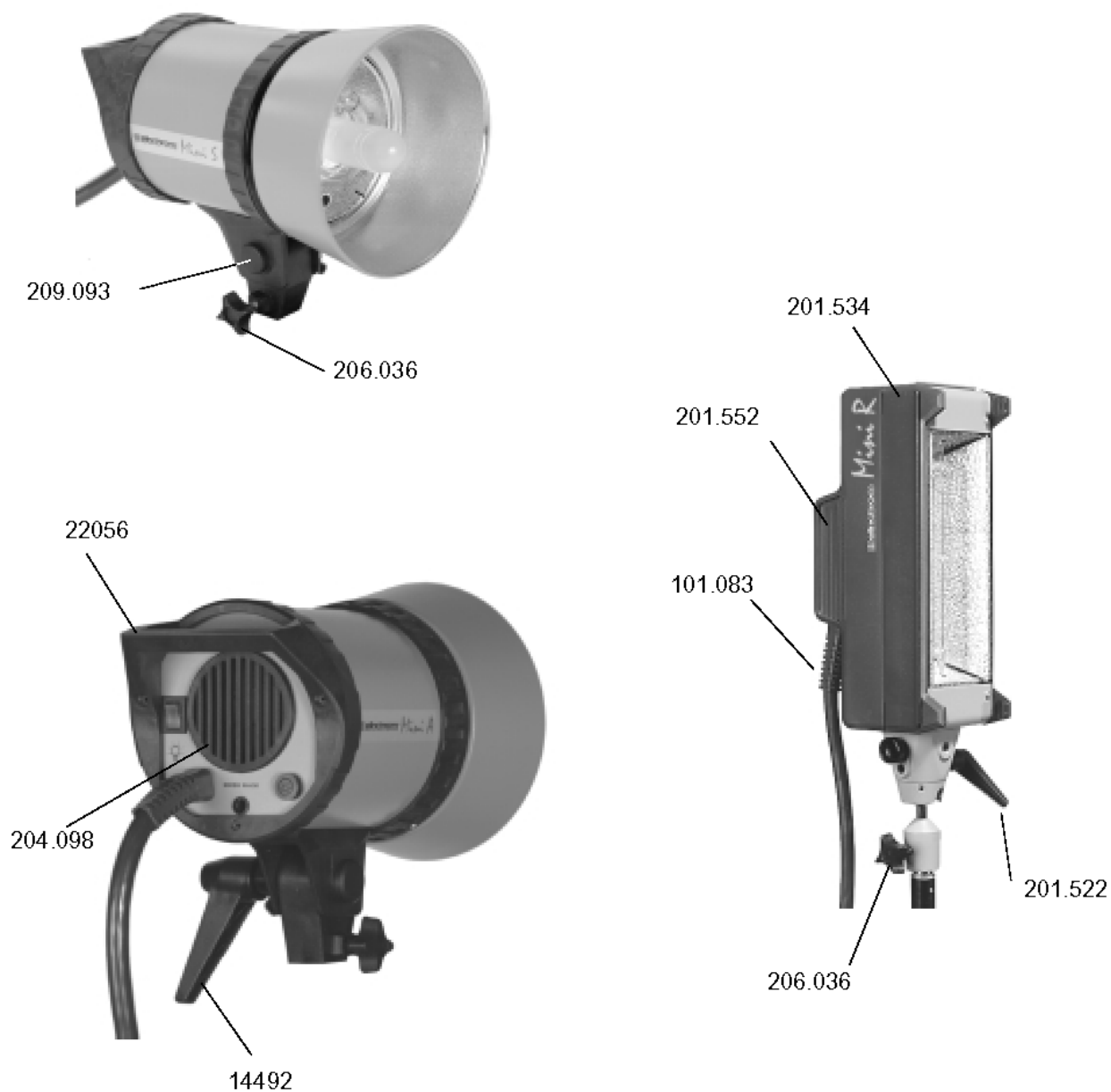

Schematic diagrams and part list

Mini A and Mini S 115V

Part List

ELINCA_NO	DESCRIPTION
20103	Lamp head complete Mini A
20105	Lamp head complete Mini S
223.001	Metal chassis
223.002	Housing without label for A and S (chemise sans etiquette)
205.178	Label Mini A (étiquette "Mini A" pour chemise)
205.177	Label Mini S
22056	Rear handle (poignée arrière)
211.601	Screw M3x8 for handle
211.602	Screw M3x12 for handle tilthead
901.201	Tilt head (rotule)
204.132	Fixe part (partie fixe)
201.656	Mobile part (partie mobile)
14492	Plastic level (poignée de serrage plastique)
209.093	Bolt M8 for handle (goujon M8 pour poignée)
201.295	Locking universal metal plate for umbrella (plaque de fixation du parapluie)
22055	Set front ring + locking device (ensemble de bagues, verrouillage + baionnettes)
211.207	Screw for front ring M3x20
204.131	Front locking (bague de verrouillage)
204.090	Front ring bayonet (bague à baionnettes)
212.203	Locking spring (ressort de verrouillage)
620.082	Umbrella tube (tube parapluie)
14594	Ring for umbrella tube (anneau plastique pour tube parapluie)
14209	Set terminal for flash tube (510.020) (5 (pack of 6) (ensemble de 6 bornes)
14212	Trigger wire diam. 0.4 (101.124) (pack of 2m length) (2m de fil d'amorçage)
25001	Trigger coil (bobine d'amorçage)
101.072	Nylon attachment for coil (attaché nylon "bride")
107.023	Fan (ventilateur)
204.098	Fan guard (grille de protection)
112.017	Lamp holder E27 (douille de lampe)
23101	Adapter for modelling lamp E27 to GX6.35
223.005	holder for terminal and socket lamp (support isolant pour bornes)
112.025	Insulating for E27 (isolation de la douille)
501.045	Lamp cord complete with connector (S) (cable de torche complet)
501.046	Lamp cord complete with connector (A)
22046	Connector 20 pM
110.053	Connector housing (boitier pour connecteur)
205.179	Label for connector (max 2400J)
101.083	Protective cable entry (pssse-cable de protection)
21003	Cable 8 conductors
23019	Modelling lamp 150W E27 clear
23012	Modelling lamp matt
103.062	Switch 12A/230V
14651	Fuse holder (support de fusible)
19032	Fuse 2AF for modelling 150W (pack of 10)
223.006	Inner reflector A
223.007	Inner reflector S
24053	Flash tube A head
24034	Flash tube S head
219.119	Insulating glass tube (trigger wire)
26124	Protective hood (capuchon)

Schematic

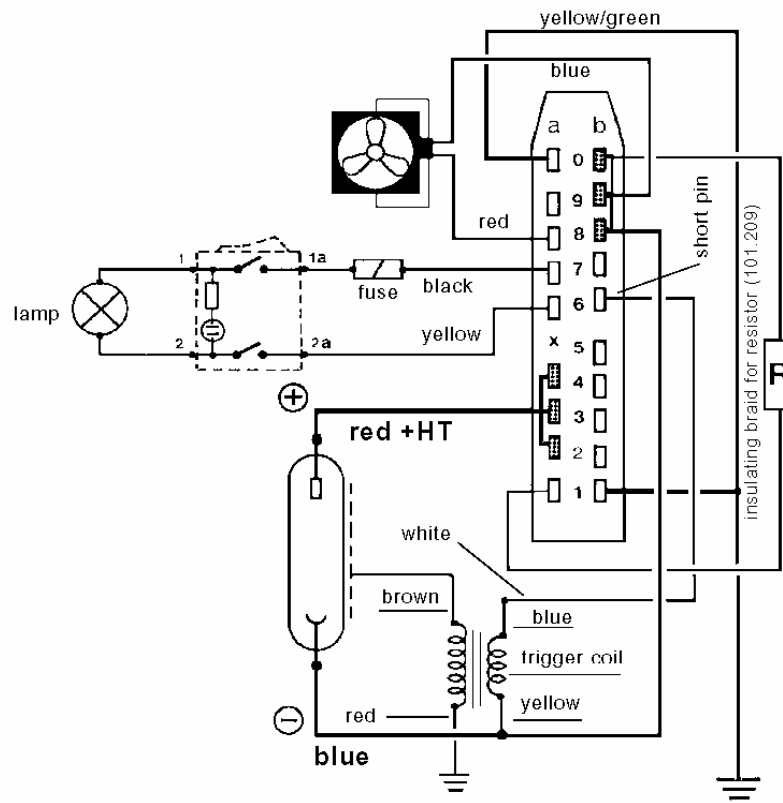

Upgrade of the Mini 1500 to Mina A or Mini S (115V version)

Transformtion des torches Mini 1500 en Mini A ou Mini S

Lampenkopfumbau von Mini 1500 auf Mini A oder Mini S

ELINCA_NO	QUANTITY	DESCRIPTION
223.002	1	Housing without label (boitier sans étiquettes)
205.177	2	Label Mini S (étiquettes)
205.178	2	Label Mini A (étiquettes)
620.218	1	Complete fan (ventilateur monté avec équerre et borne de raccordement)
620.216	1	Front part complete Mini S (partie avant complète)
620.215	1	Front part complete Mini A
211.204	2	Screw M3x10 (vis d'assemblage du ventilateur sur la partie avant)
203.031	2	Nut M3
620.082	1	Umbrella tube with protected wire (tube parapluie avec fil de mise à la terre)
205.179	1	Label for connector
121.101	1	recognition resistor 100R for S head
121.221	1	recognition resistor 100R for A head
24034	1	Flash tube S head (max. 2400J)
24053	1	Flash tube A head

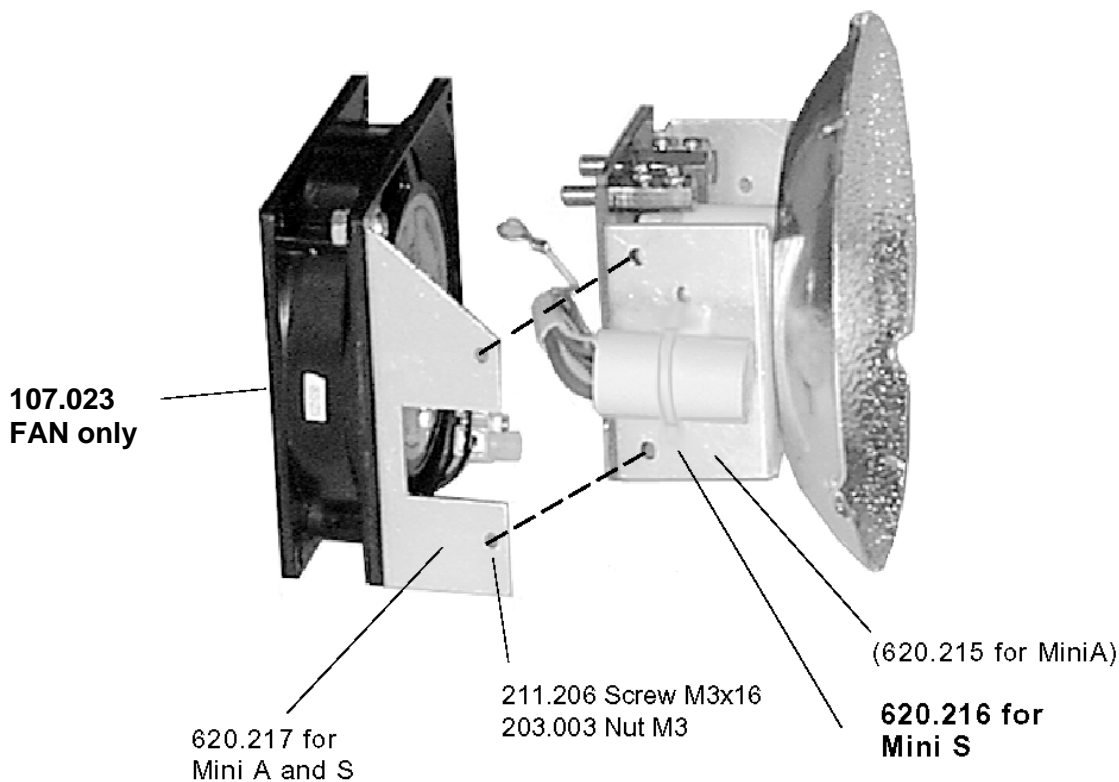

Rectangular Lamp head Mini R (115V version)

Schematic

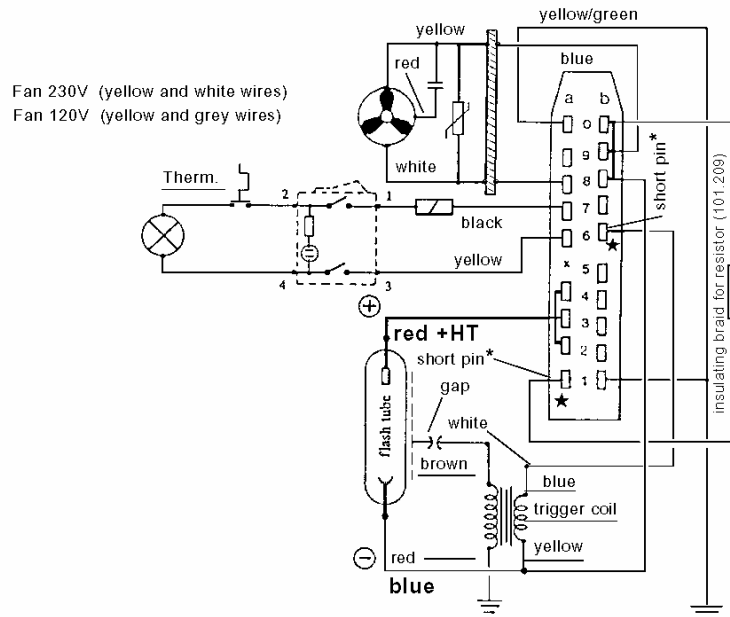

Part List

ELINCA_NO	DESCRIPTION
20159	Lamp head complete
520.004	Metal chassis
625.092	Universal stand mounting complete (tilthead) (fixation universelle à rotule)
201.522	Plastic level for tilt head (poignée de serrage)
206.036	Star screw M6x17 (vis étoile)
201.552	Plastic housing left + right parts (jeu de plaques laterales sérigraphiées)
620.307	Reflector complete with fan and socket (prémontage de la partie avant, calotte, ventilateur)
620.309	Insulating socket for halogene and flash tube (pièce isolante supportant la borne 201.507)
201.507SAV	SAV Terminal for flash tube with screws (complete) (borne de fixation du tube flash)
212.102	Ball "sealing" of lead, 3mm for electrical contact (bille de plomb de 3mm pour contact électrique)
107.012	Fan 120V (ventilateur)
620.203	Print assembly (support de bornes assemble)
111.059	Varistor 250V
104.057	Capacitor 0,68uF/400V
25001	Trigger coil M6 (bobine d'amorçage)
101.077	Nylon strap for trigger coil
106.035	Protective gap (éclteur)
106.037	Thermal switch 110/90°
520.003	Trigger nickel flat wire (fil d'amorçage)
14651	Fuse holder (support de fusible)
19037	Fuse 8A for lamp 500W (pack of 10)
103.062	Switch 12A 250V (interrupteur)
21060	Lamp cord complete with connector (cable de torche complet)
14043	Connector 20pM with housing complete
22046	Connector 20pM only (short pins 112.062) (connecteur 20pM seul)
110.053	Connector housing L+R parts (boitier pour connecteur)
21002	Cable 8 conductors
101.083	Protective cable entry (passé-cable de protection)
121.101	Coding resistance 1W 1%
14211	Insulating braid for resistor (101.209) (pack of 0.5m)
23028	Modelling halogene lamp 650W socket R7S (lampe halogène rectiligne de 650W)
24019	Flash tube (24022 for Digital RE)
209.019	Insulating tube (glass) for trigger flat wire

NOTES

A series of horizontal dotted lines intended for taking notes.